

DESIGN GUIDE

Interface for use in BACnet®

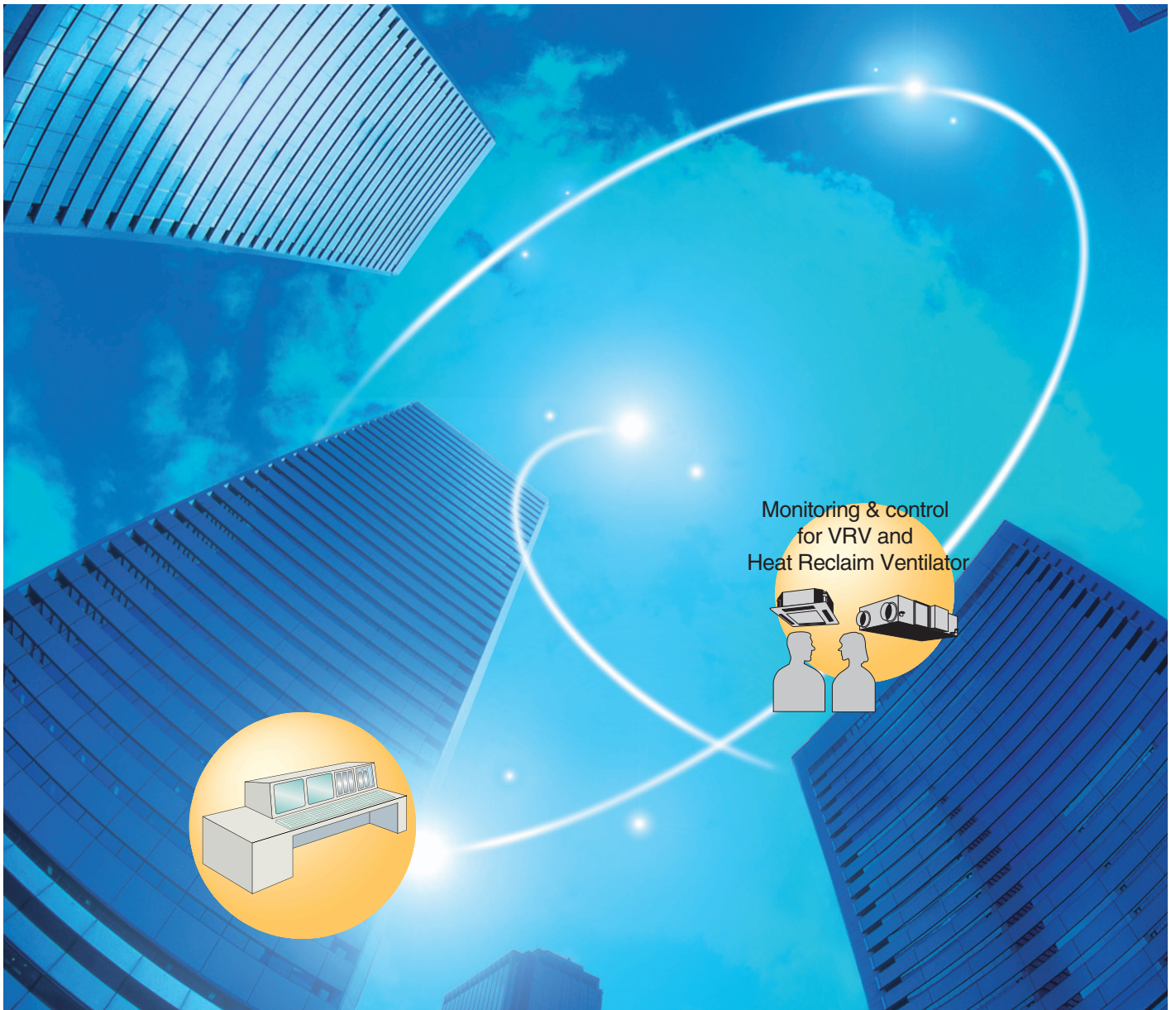

Table of Contents 1

Part 1 Interface for use in BACnet® 1 2

1. BACnet® Interface.....	2	
1.1 Outline and Features.....	2	
1.2 System Outline.....	2	3
1.3 System Configuration.....	3	
1.4 Specifications.....	4	
1.5 Components.....	4	
1.6 Dimensions.....	4	4
1.7 BACnet® Object List.....	6	
1.8 Names and Functions of Each Part.....	7	
1.9 Electric Wiring.....	9	
1.10 Functions.....	13	
1.11 Backup Systems for Troubles.....	15	5
1.12 BMS (Building Management System).....	16	
1.13 Adopting “Super Wiring System”.....	16	

Part 2 Functional Specifications 17 6

1. Introduction.....	19	
2. Network Topology.....	19	
3. Air Conditioner Monitor/Control Items.....	20	
4. Supported Models and Monitor/Control Items.....	21	7
5. BACnet® Protocol Implementation Conformance Statement (PICS)....	22	
6. BACnet® Interoperability Building Blocks Supported (BIBBs).....	23	
6.1 Data Sharing BIBBs.....	23	8
6.2 Alarm and Event Management BIBBs.....	23	
6.3 SCHEDuling BIBBs.....	24	
6.4 Trending BIBBs.....	24	
6.5 Device Management BIBBs.....	24	
6.6 Network Management BIBBs.....	25	9
7. Objects.....	26	
7.1 Supported Object Type.....	26	
7.2 Member Objects.....	27	
8. Properties.....	32	
8.1 Accumulator Object Type.....	32	
8.2 Analog Input Object Type.....	33	
8.3 Analog Value Object Type.....	35	
8.4 Binary Input Object Type (Supported Intrinsic Reporting).....	36	
8.5 Binary Input Object Type (Non-supported Intrinsic Reporting).....	37	
8.6 Binary Output Object Type.....	39	
8.7 Binary Value Object Type.....	40	
8.8 Device Object Type.....	42	
8.9 Multi-state Input Object Type.....	43	
8.10 Multi-state Output Object Type.....	44	

9. Report Function.....	45
9.1 COV Notification.....	45
9.2 Event Notification	46
10. Error Response in BACnet® Communication.....	48
11. Detailed Description of Objects.....	49
11.1 Common to All Objects.....	49
11.2 Start/Stop (Setting).....	50
11.3 Start/Stop (Status).....	50
11.4 Alarm	51
11.5 Malfunction Code	51
11.6 Air-conditioning Mode (Setting).....	52
11.7 Air-conditioning Mode (Status).....	52
11.8 Airflow Rate Level (Setting).....	53
11.9 Airflow Rate Level (Status).....	53
11.10 Measured Room Temperature.....	54
11.11 Set Room Temperature	55
11.12 Filter Sign Signal.....	56
11.13 Filter Sign Signal Reset	56
11.14 Remote Controller Enable/Disable (Start/Stop).....	57
11.15 Remote Controller Enable/Disable (Air-conditioning Mode).....	57
11.16 Remote Controller Enable/Disable (Set Temperature).....	57
11.17 Central Control (Lower Central Control Disable).....	58
11.18 Accumulated Power.....	58
11.19 Communication Status.....	59
11.20 Forced System Stop	59
11.21 Air Direction (Setting).....	60
11.22 Air Direction (Status).....	60
11.23 Forced Thermostat Disable (Setting).....	61
11.24 Forced Thermostat Disable (Status).....	61
11.25 Energy Saving (Setting).....	61
11.26 Energy Saving (Status).....	61
11.27 Thermostat Status	62
11.28 Compressor Status	62
11.29 Indoor Fan Status	62
11.30 Heater Operation Status	62
11.31 Ventilation Mode (Setting)	63
11.32 Ventilation Mode (Status)	63
11.33 Ventilation Amount (Setting).....	64
11.34 Ventilation Amount (Status).....	64
12. Others	65
12.1 Initial Status at Start-up	65
12.2 BACnet® Network Layer.....	65
12.3 Time Adjustment	65
12.4 Device Communication Control Service.....	65
13. Appendix A: PICS	
(D-BACS Interface for use in BACnet® Ver. 6.10)	67
13.1 BACnet® Protocol Implementation Conformance Statement.....	67
14. Appendix B: PICS	
(D-BACS Interface for use in BACnet® Ver. 6.20)	73
14.1 BACnet® Protocol Implementation Conformance Statement.....	73
15. Appendix C: PICS	
(D-BACS Interface for use in BACnet® Ver. 6.30)	79

15.1 BACnet [®] Protocol Implementation Conformance Statement	79	1
Part 3 Point List	85	
1. BACnet [®] Point List.....	86	
Part 4 Daikin's Agreement	95	2
1. Daikin's Interface for use in BACnet [®] Agreement.....	96	
Part 5 Test Operation Manual.....	97	3
1. BACnet [®] Object System Diagram of Interface for use in BACnet [®]	98	
2. Specifications of Interface for use in BACnet [®] (1)	99	
3. Specifications of Interface for use in BACnet [®] (2)	100	4
4. Before Visiting the Site	101	
4.1 Check the Specifications of the PC and Communication Cable Used for the Trial Operation as well as the Version of the Trial Operation Program.....	101	
4.2 Obtaining Object Information.....	102	5
4.3 Setting the Trial Operation PC Modem (When Connecting the Interface for use in BACnet [®] and the Trial Operation PC Using RS232C Communication).....	105	
5. Work Procedure for the Interface for use in BACnet [®]	115	6
5.1 Connect the Trial Operation PC and Interface for use in BACnet [®] Via the RS232C Cross Cable or the Hub Using the 100BASE-TX Straight Cable	116	
5.2 Start the Trial Operation Program. (On the Trial Operation PC, Double-click SetupBACnet [®] .) Enter the IP Address	118	7
5.3 Setting	120	
5.4 Reset the Interface for use in BACnet [®]	131	
5.5 Start the Trial Operation Program	134	
5.6 Select the Operation Status Menu and Check the Following.....	136	8
5.7 Check the Registration of Management Point Types	137	
5.8 Check the All Points from the Central Control Panel.....	138	
6. Reference: Items which do not Need to be Changed from the Factory Settings	140	9
7. Q & A.....	147	
Part 6 Test Run Manual (PPD)	153	
1. Test Run Procedures	156	
2. Connection between Service PC and Interface for use in BACnet [®] ...	157	
2.1 Wiring	157	
2.2 Setting of IP Address (Windows 2000).....	158	
3. Setting of Pulse Rate (Using SetupBACnet [®] .exe)	160	
4. Startup of PPD Test Run Tools (Using SetupPPD.exe).....	164	
5. Initializing	165	
6. Setting of Ports.....	166	
7. Hardware Setting	167	
7.1 Automatic Setting	168	
7.2 Manual Setting	169	

8. Power Distribution Group Setting.....	170
8.1 Power Distribution Group Editing	171
9. Confirmation of Operation	172
9.1 Detailed Explanation for Confirmation Window	173
9.2 Confirmation Window, Normal Model.....	174
9.3 Confirmation of the Type of Wattmeter	178
9.4 Confirmation of Pulse Input	179
9.5 Confirmation of Integrated Values, Normal Model	180
10. Error Messages.....	182

Part 7 Installation Manual 183

1. Installation Manual	184
1.1 DMS502B51	184
1.2 DAM411B51 (Option DIII Board).....	190
1.3 DAM412B51 (Option Di Board).....	193

Part 8 Troubleshooting 197

1. Troubleshooting Interface for use in BACnet [®] with LED indication.....	198
1.1 Troubleshooting with CPU ALIVE LED, CPU ALRM (ALARM) LEDs	198
1.2 Troubleshooting with ETHER LINK LED, ETHER RCV LEDs	200
1.3 Troubleshooting with DIII-1-4 LEDs	201
1.4 Troubleshooting with RS232C-1 TxD, RxD LEDs	202
1.5 Troubleshooting with RS232C-2 TxD, RxD LEDs	203

Part 9 Interface for use in BACnet[®] Project Job Flow 205

1. Interface for use in BACnet [®] Project Job Flow	206
1.1 Engineering Flow of Interface for use in BACnet [®] until Installation.....	206
1.2 Initial Settings Required Items for Interface for use in BACnet [®]	208

Part 1

Interface for use in

BACnet®

1. BACnet® Interface.....	2
1.1 Outline and Features.....	2
1.2 System Outline.....	2
1.3 System Configuration.....	3
1.4 Specifications.....	4
1.5 Components.....	4
1.6 Dimensions.....	4
1.7 BACnet® Object List.....	6
1.8 Names and Functions of Each Part.....	7
1.9 Electric Wiring.....	9
1.10 Functions.....	13
1.11 Backup Systems for Troubles.....	15
1.12 BMS (Building Management System).....	16
1.13 Adopting “Super Wiring System”.....	16

1. BACnet® Interface

1.1 Outline and Features

1. Managing the information on 128 groups of air-conditioners (main units only).
2. Up to 256 groups manageable and controllable at once by adding the optional DIII board
3. Packaging of air-conditioner objects
 - * Compatible with BACnet® (ANSI / ASHRAE-135)
 - * Compatible with BACnet® / IP (ISO16484-5)
4. Conforming to European, Oceanian, Safety and EMC rules and regulations.



1.2 System Outline

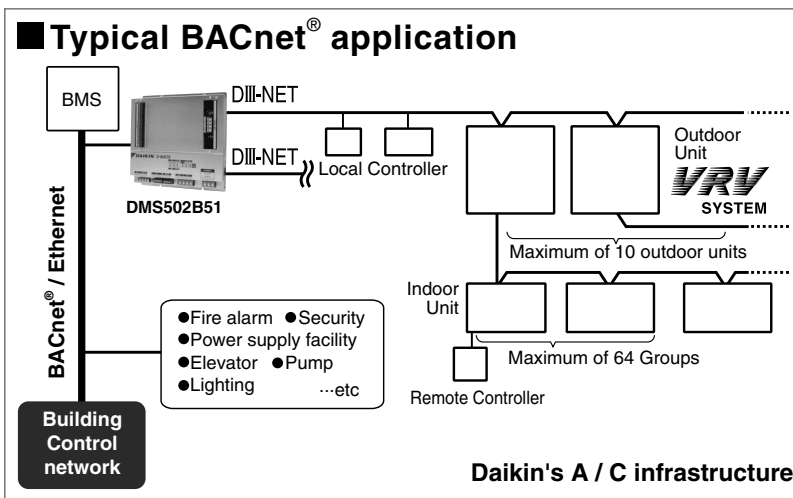

Outline of air-conditioner management system control devices

Interface for use in BACnet® (DMS502B51)	Interface unit to allow communications between VRV and BMS. Operation and monitoring of air conditioning systems through BACnet® communication.
Optional DIII board (DAM411B51)	Expansion kit, installed on DMS502B51 to provide 2 more DIII-NET communication ports. Not usable independently.
Optional Di board (DAM412B51)	Expansion kit, installed on DMS502B51 to provide 12 more wattmeter pulse input points. Not usable independently.

Note:

1. A group consists of several indoor units that can be started or stopped simultaneously. As shown in the figure above, a group consists of several indoor units wired to the same remote controller. For units without a remote controller, each unit is treated as a group.
2. Several groups are registered as a zone with the central remote controller. By pressing 1 button of the central remote controller, all groups within the same zone can be turned on or off simultaneously.

1.3 System Configuration

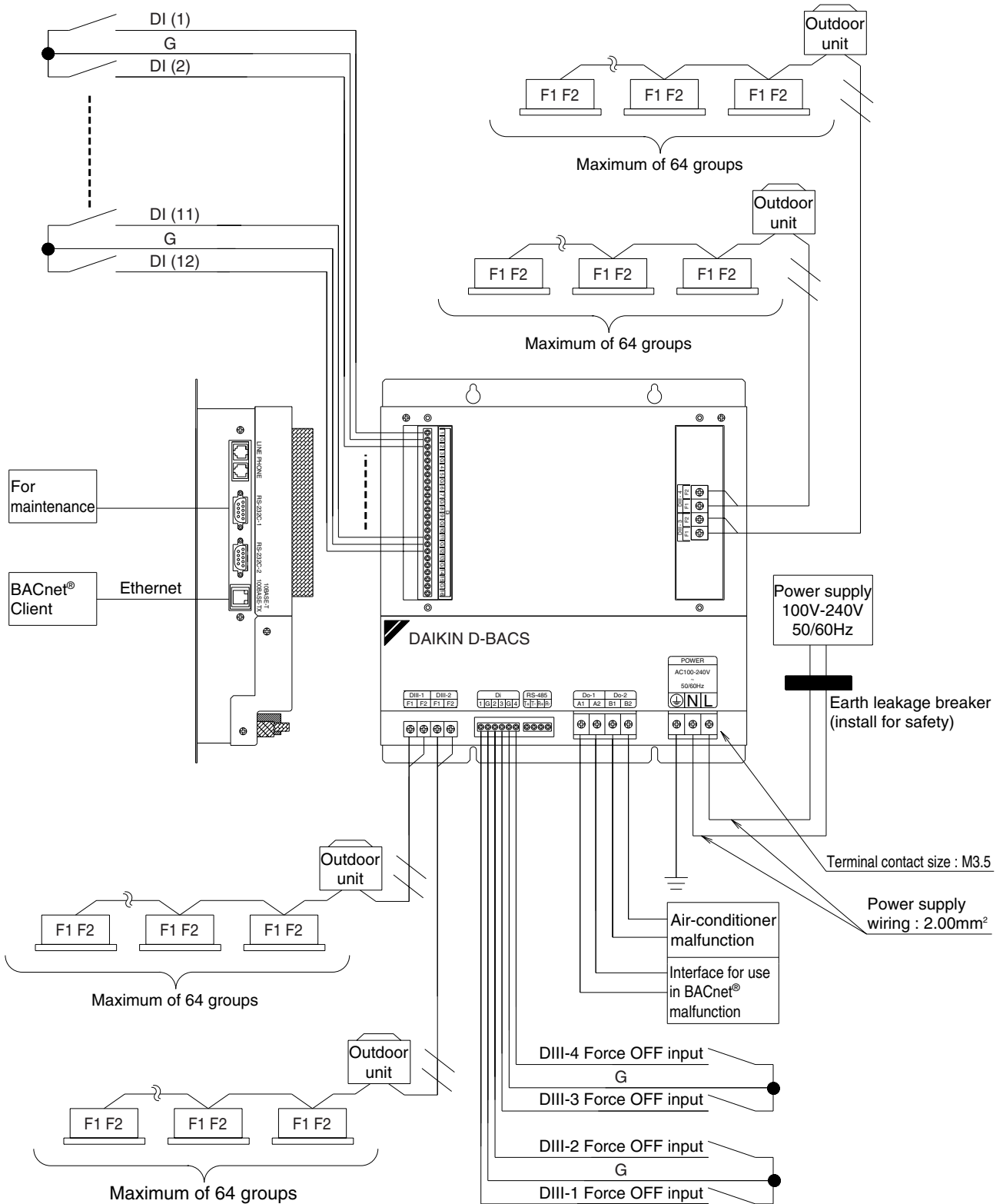

1P191170D

1.4 Specifications

Rated Electrical Conditions	Rated Voltage and Frequency	Single Phase AC 100~240V, 50/60 Hz
	Rated Power	Maximum 20W
Conditions for Use	Power Supply Fluctuation	±10% of the Rated Value
	Outdoor Air Temperature	-10~+50°C
	Ambient Humidity	0~90% (Sweating is not acceptable)
	Preservation Temperature	-15~+60°C
Performance	Insulation Resistance	50MΩ or more by DC500 megaohmmeter
Mass		2.8 kg
Colour of the Unit		Stainless steel

1.5 Components

The following parts are attached to this unit.
Make sure to check them before installation.

BACnet® Interface	1 set
INSTALLATION MANUAL	1 copy

1.6 Dimensions

Outside drawing of DMS502B51

Unit (mm)

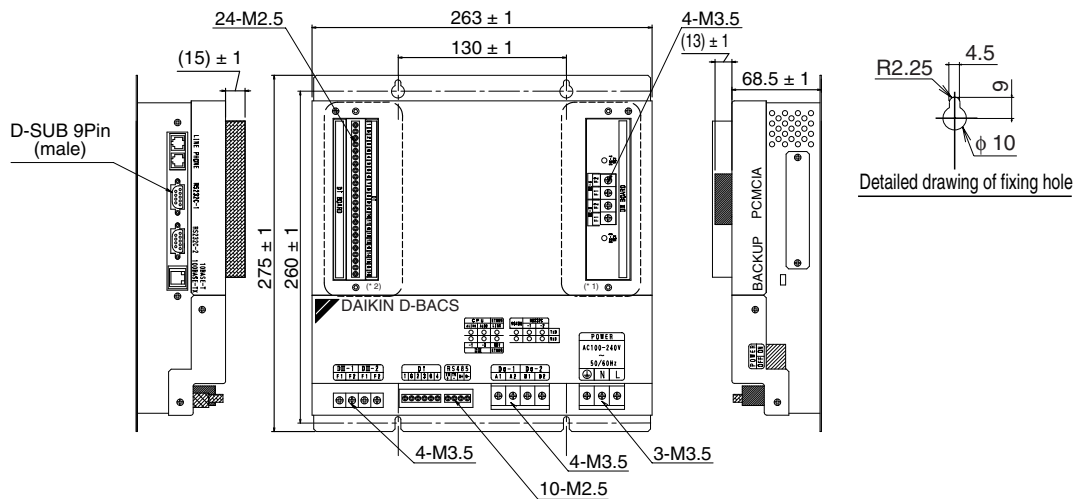

(*1) The drawing within the dotted line shows how the OPTION DIII BOARD(DAM411B51) is installed

(*2) The drawing within the dotted line shows how the OPTION Di BOARD(DAM412B51) is installed

- 1) Rated electrical conditions
 - (1) Rated voltage and frequency : Single phase AC100-240V, 50/60Hz
 - (2) Rated power : Maximum 20W
- 2) Conditions for use
 - (1) Power supply fluctuation : ±10% of the rated value
 - (2) Outdoor air temperature : -10~ +50°C
 - (3) Ambient humidity : 0~90% (Sweating is not acceptable)
 - (4) Preservation temperature : -15~ +60°C
- 3) Performance Insulation resistance : 50MΩ or more by DC500 megohmmeter
- 4) Mass : 2.8Kg
- 5) Colour of the unit : Stainless steel

C: 3D056945B

Outline of functions of DAM411B51

This unit is for adding 2 port to the DIII-NET communication port by installing it on the Interface for use in BACnet® DMS502B51.

● **Make sure to connect the unit with [DIII-NET master]**

(Do not remove the master central setting connector.)

When using together with other centralized control equipment such as central remote controllers or ON/OFF controllers, remove the master central setting connectors of the central remote controllers or ON/OFF controllers

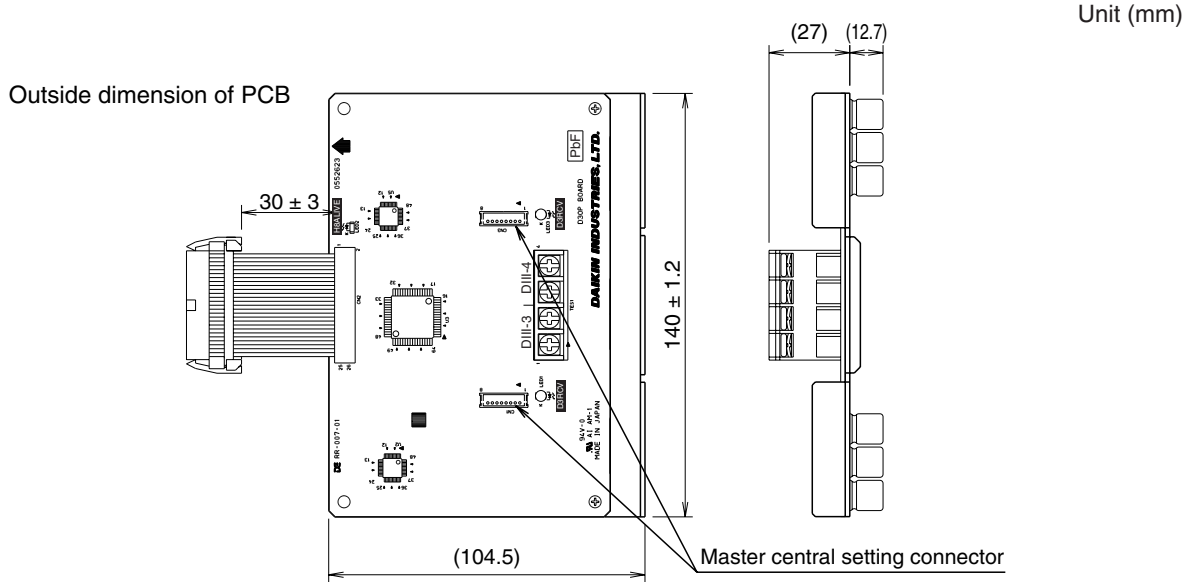

C: 1P191165C

Outline of functions of DAM412B51

This unit is for 12 points of Di input (no voltage contact input) by installing it on the Interface for use in BACnet® DMS502B51.

Outside dimension of PCB

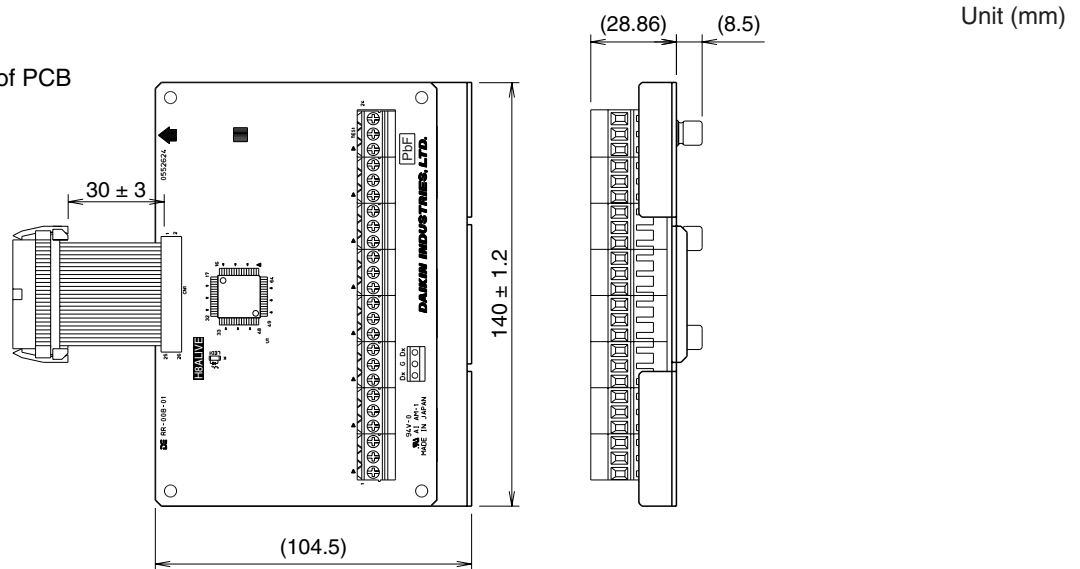

1P191166D

1.7 BACnet® Object List

Each air conditioner management point is mapped to the corresponding BACnet® object's instance number. The BACnet® object uses the data field of the instance number 22 as shown below.

31	22	21	16	15	8	7	0
BACnet® object type	Not used (zero)		Air conditioner number		Member number		

The air conditioner number represents the number used by the air conditioner line to manage each air conditioner and the BACnet® clients (HIM and other ICONT devices) use this number to specify the air conditioner. Each member number corresponds to each management item for the air conditioner, as defined in the following object list.

Member number	Standard name	Object name (XXX represents the air conditioner number.)	Object type	Unit					
				Inactive	Active				
				Text-1	Text-2	Text-3	Text-4	Text-5	Text-6
1	Start/stop (setting) (Note 2)	StartStopCommand_XXX	BO	Stop	Operation				
2	Start/stop (status)	StartStopStatus_XXX	BI	Stop	Operation				
3	Alarm	Alarm_XXX	BI	Normal	Malfunction				
4	Malfunction code	MalfunctionCode_XXX	MI	Normal	Manufacturer specific				
5	Air-conditioning mode (setting) (Note 2) (Note 3)	AirConModeCommand_XXX	MO	Cooling	Heating	Fan	Auto	Dry	
6	Air-conditioning mode (status)	AirConModeStatus_XXX	MI	Cooling	Heating	Fan	(Not used)	Dry	
7	Airflow rate level (setting) (Note 2)	AirFlowRateCommand_XXX	MO	Low	High	Middle	Auto		
8	Airflow rate level (status)	AirFlowRateStatus_XXX	MI	Low	High	Middle	Auto		
9	Measured room temperature (Note 1)	RoomTemp_XXX	AI	°C/°F					
10	Set room temperature (Note 2)	TempAdjust_XXX	AV	°C/°F					
11	Filter sign signal	FilterSign_XXX	BI	No	Yes				
12	Filter sign signal reset	FilterSignReset_XXX	BV	Reset					
13	Remote controller enable/disable (start/stop)	RemoteControlStart_XXX	BV	Enabled	Disabled				
14	Remote controller enable/disable (air-conditioning mode)	RemoteControlAirConModeSet_XXX	BV	Enabled	Disabled				
15	Blank								
16	Remote controller enable/disable (set temperature)	RemoteControlTempAdjust_XXX	BV	Enabled	Disabled				
(*17)	Central control (lower central control disable)	CL_Rejection_XXX	BV	Enabled	Disabled				
18	Accumulated gas (Note 4)	Gas TotalPower_XXX	Accumulator	m ³					
19	Accumulated power	ElecTotalPower_XXX	Accumulator	kWh					
20	Communication status	CommunicationStatus_XXX	BI	Normal communication	Communication error				
(*21)	Forced system stop	SystemForcedOff_XXX	BV	Clearance	Forced stop				
22	Air direction (setting) (Note 2)	AirDirectionCommand_XXX	AV						
23	Air direction (status)	AirDirectionStatus_XXX	AI						
24	Forced thermostat disable (setting)	ForcedThermoOFFCommand_XXX	BO	Clearance	Set				
25	Forced thermostat disable (status)	ForcedThermoOFFStatus_XXX	BI	Clearance	Set				
26	Energy saving (setting)	EnergyEfficiencyCommand_XXX	BO	Clearance	Set				
27	Energy saving (status)	EnergyEfficiencyStatus_XXX	BI	Clearance	Set				
28	Thermostat status	ThermoStatus_XXX	BI	OFF	ON				
29	Compressor status	CompressorStatus_XXX	BI	Stop	Operation				
30	Indoor fan status	IndoorFanStatus_XXX	BI	Stop	Operation				
31	Heater operation status	HeaterStatus_XXX	BI	Stop	Operation				
32	Ventilation Mode (setting)	VentilationModeCommand_XXX	MO	Bypass	ER Ventilation	Auto			
33	Ventilation Mode (status)	VentilationModeStatus_XXX	MI	Bypass	ER Ventilation	Auto			
34	Ventilation Amount (setting)	VentilationAmountCommand_XXX	MO	Low	High	Auto	Low (fresh up)	High (fresh up)	Auto (fresh up)
35	Ventilation Amount (status)	VentilationAmountStatus_XXX	MI	Low	High	Auto	Low (fresh up)	High (fresh up)	Auto (fresh up)

Central control (lower central control disable) and forced system stop are only available for 000, 064, 128, and 192.

- Note:**
- The room temperature is measured with the suction air. Since the indoor unit fan stops when the thermostat is disabled or the air conditioner is stopped, or in a special operation such as defrosting, temperature measurement may be affected by the heat exchanger, and may detect and transmit a different temperature from the actual room temperature. For this reason, this value should be considered as a reference for the room temperature. If the building management system manufacturer uses this value for system control (e.g., switching the air-conditioning mode or preset temperature), the manufacturer must take on the whole responsibility.
 - The air conditioner saves the settings for the temperature, start/stop status, air-conditioning mode, air direction, and airflow rate in the nonvolatile memory each time they are changed, so that the settings will not be lost when a power cut occurs. This nonvolatile memory has a write count limit and may cause a failure if it is written exceeding the limit count. Therefore when the temperature, start/stop status, air-conditioning mode, air direction, and airflow rate of each indoor unit are automatically controlled from the central monitoring panel, be sure that the number of changes for each setting **should not exceed 7, 000 times per year**.
 - If the operation mode is set to "Dry", any indoor unit with no cooling/heating selection right for the same refrigerant system will not change to the "Dry" mode except in the cooling mode.
 - Member number 18 is for Japanese market only.

1.8 Names and Functions of Each Part

Unit (mm)

1

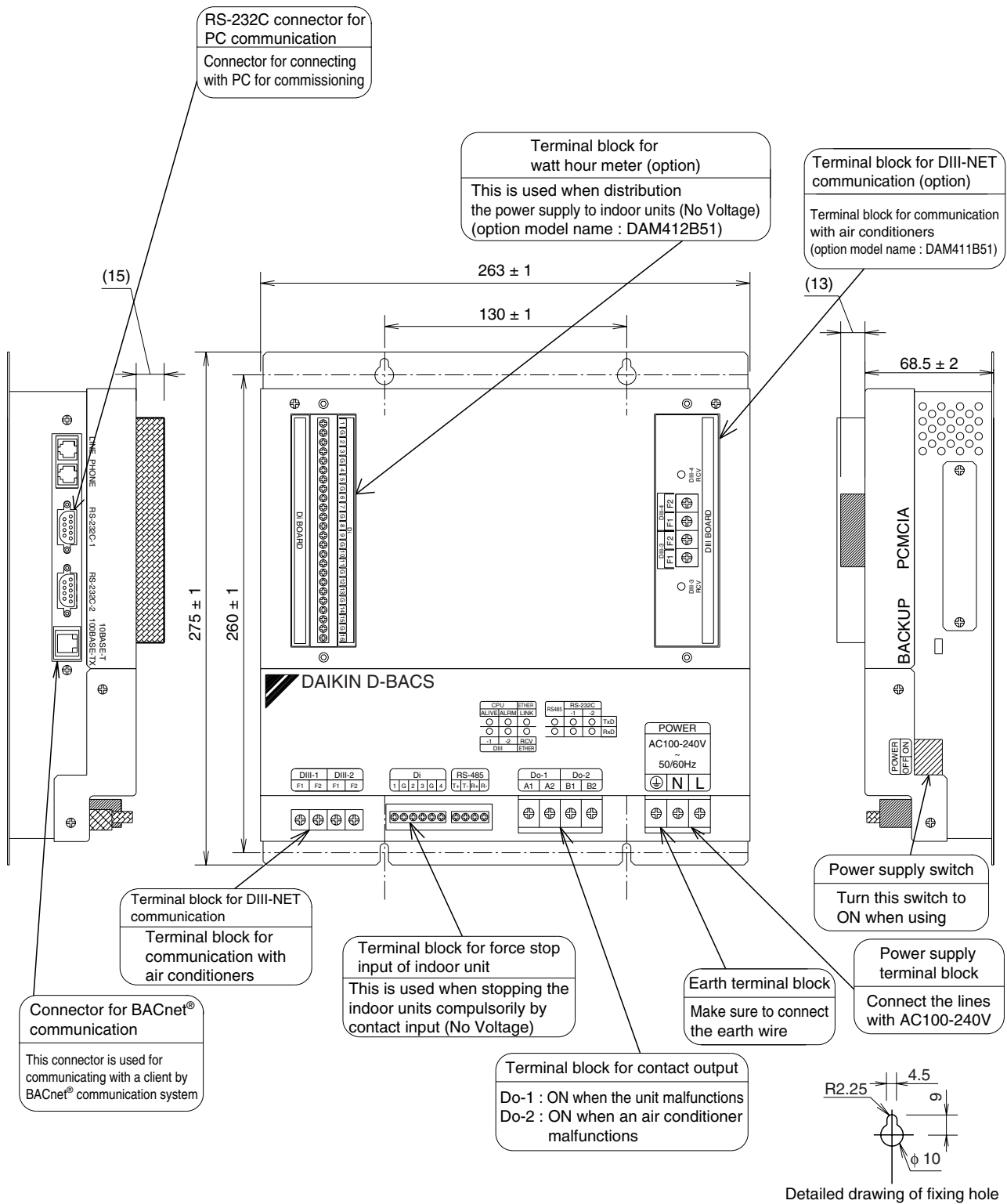

1P191169D

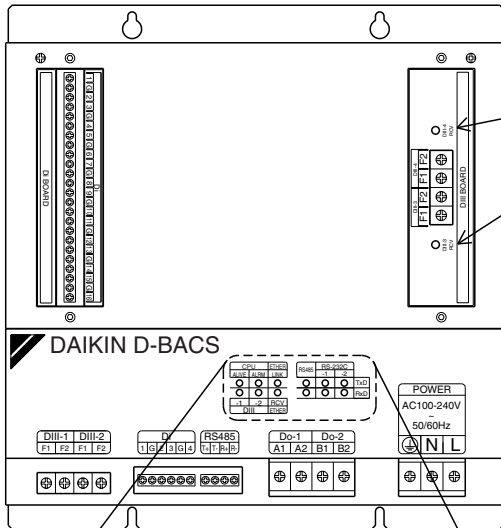

LED display

DIII-4 RCV	It flashes when it receives/transmits data from/to the equipment connected with DIII-4 such as air conditioners
DIII-3 RCV	It flashes when it receives/transmits data from/to the equipment connected with DIII-3 such as air conditioners

LED display

CPU ALIVE	It flashes when the unit is normal operation.
CPU ALRM	It flashes when the unit is abnormal operation.
DIII-1	It flashes when it receives/transmits data from/to the equipment connected with DIII-1 such as air conditioners
DIII-2	It flashes when it receives/transmits data from/to the equipment connected with DIII-2 such as air conditioners
Ether RCV	It flashes when it receives/transmits data from/to BACnet® client
Ether Link	It lights when the 10BASE-T cable or 100BASE-TX cable
RS-485 (TxD)	This LED display cannot be used with this unit
RS-485 (RxD)	This LED display cannot be used with this unit
RS-232C-1 (TxD)	It flashes when it transmits data to PC
RS-232C-1 (RxD)	It flashes when it receives data to PC
RS-232C-2 (TxD)	This LED display cannot be used with this unit.
RS-232C-2(RxD)	This LED display cannot be used with this unit.

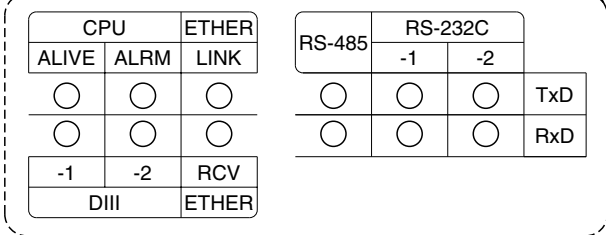

1.9 Electric Wiring

1.9.1 [DIII-NET Master] Setting

- **Make sure to connect the unit with [DIII-NET master]**
 (Do not remove the master central setting connector.)
 When using together with other centralized control equipment such as central remote controllers or ON/OFF controllers, remove the master central setting connectors of the central remote controllers or ON/OFF controllers.

1.9.2 System Wiring

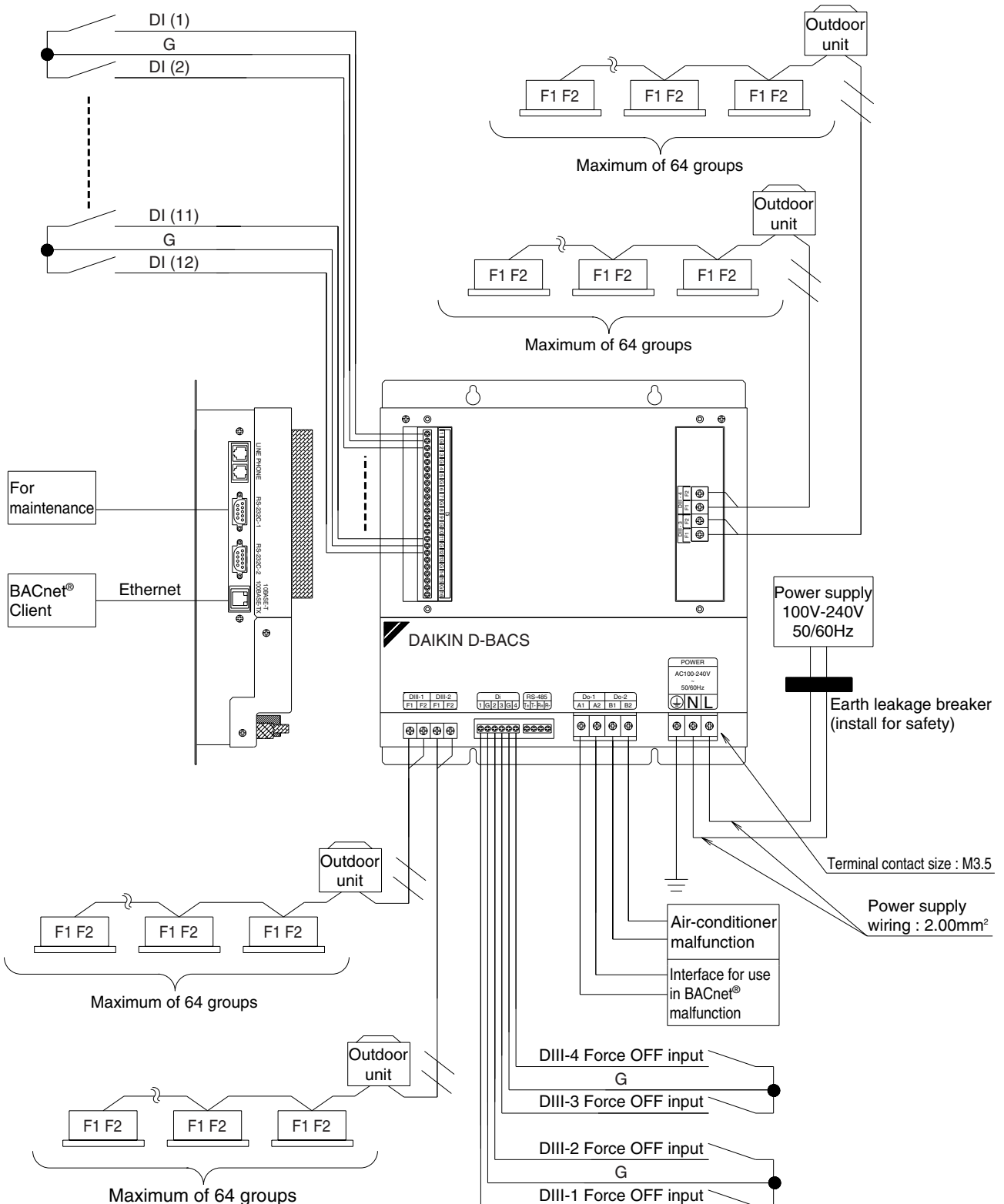

1.9.3 Electric Wiring Connections

- Everything relating with field wiring must be supplied in the field.

1. DIII-NET Wiring

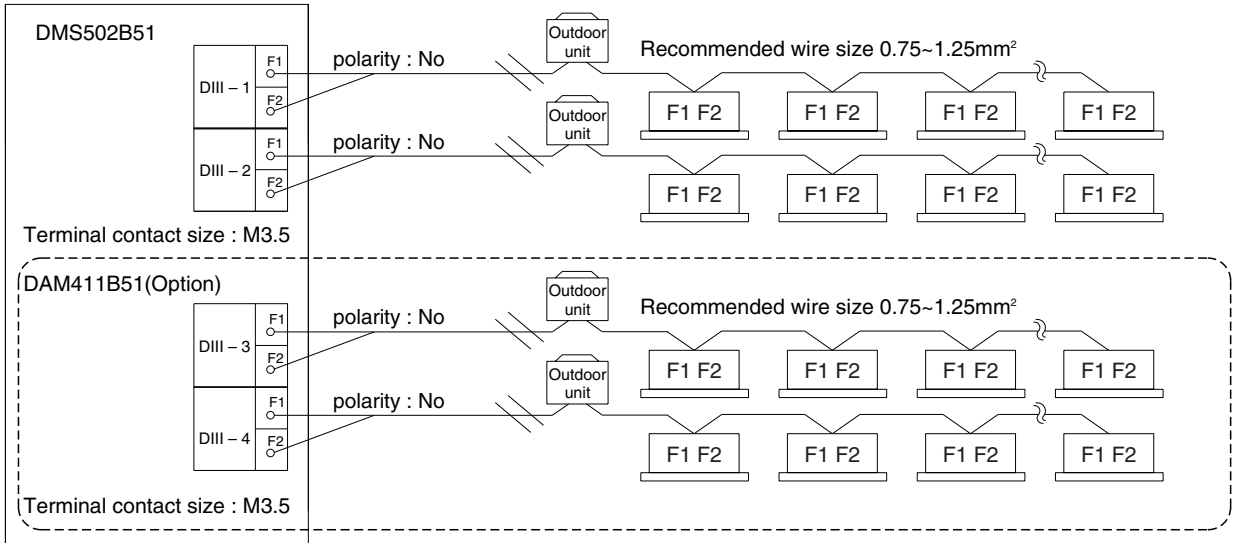

● **Cautions for wiring**

1. Do not use multicore cables with three or more cores
2. Use wires of sizes between 0.75mm² and 1.25mm²
3. Do not bind the wire for DIII-NET
4. Wirings for DIII-NET must be isolated from the power lines
5. Wire length : Max 1000m

1P191170D

2. No Voltage Contact Input Wiring

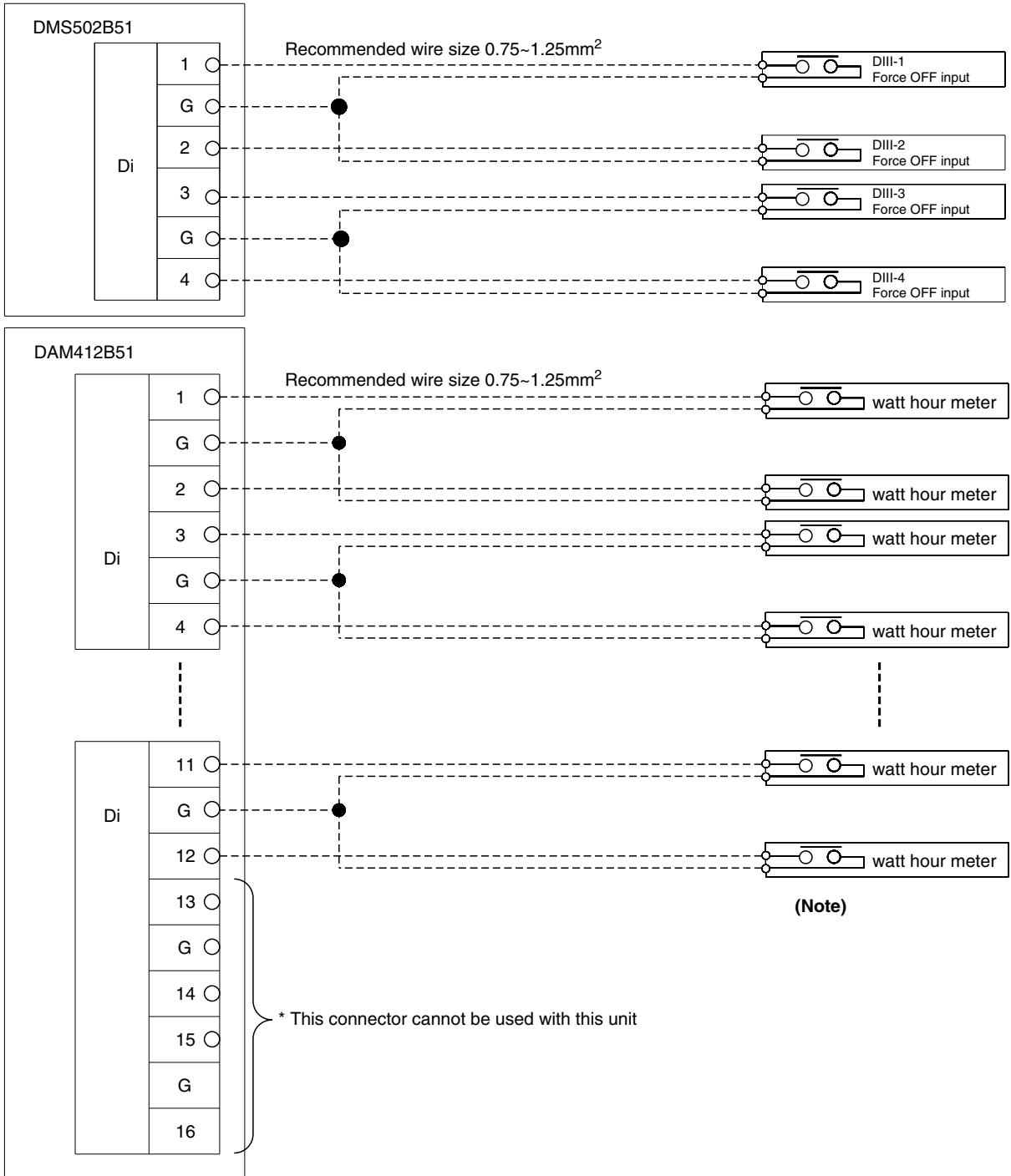

Note:

Use a meter that outputs one pulse of a width from 40~400msec, per 1 kWh.

The pulse of watt hour meter

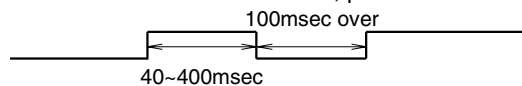

● **Cautions for wiring**

1. The input are all the no voltage contact
2. Use a contact which can guarantee minimum application load DC16V and 10mA
3. Do not use multicore cables with 3 or more cores
4. Use wires of sizes between 0.75mm² and 1.25mm²
5. Do not bind the wire for control
6. Wirings for control must be isolated from the power lines
7. Terminals G are inter-connected. Connecting to either one is allowed, but the number of cables connectable to one terminal is limited to 2 pieces
8. Wire length : Max 150m

3. No Voltage Contact Output Wiring

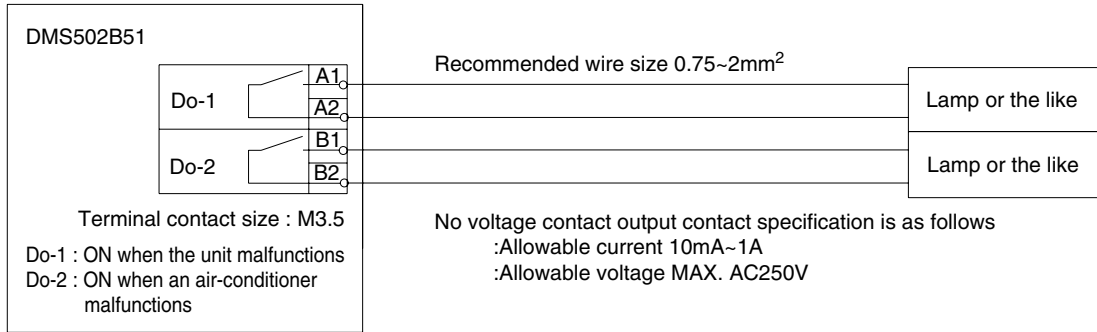

● **Cautions for wiring**

1. Do not use multicore cables with 3 or more cores.
2. Use wires of sizes between 0.75mm² and 2mm².
3. Do not bind the wire for control.
4. Wirings for control must be isolated from the power lines.
5. Wire length : Max 150m

4. Ethernet Communication Wiring

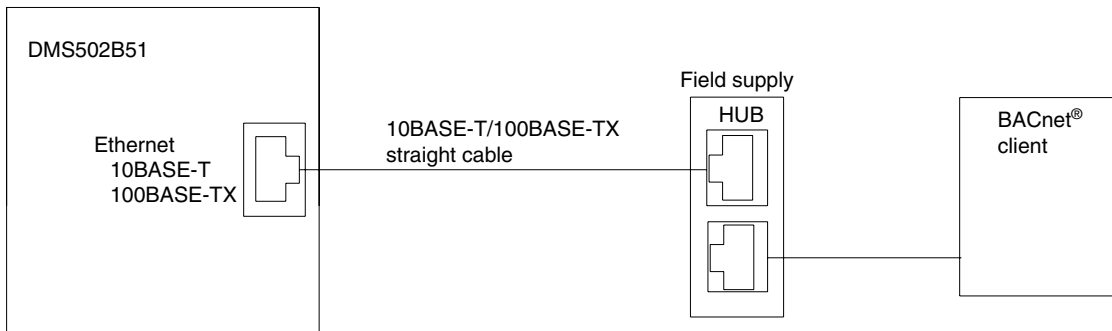

● **Cautions for wiring**

Do not clamp these cables together with high voltage cables.
Failure to observe this instruction would cause control error.

1P191170D

1.10 Functions

1.10.1 Air Conditioner Monitor / Control Items

The table below lists the air conditioner items that can be monitored and controlled via the BACnet® communication.

Function	Description	
Monitor	Start/stop status	Monitors the start/stop status of the air conditioner.
	Alarm	Monitors whether or not the air conditioner is operating normally, and issues an alarm if the air conditioner has a malfunction.
	Malfunction code	Displays a malfunction code specified by the manufacturer if an air conditioner in the system has a malfunction.
	Air-conditioning mode	Monitors if the air conditioner is cooling, heating, ventilating or dry.
	Room temperature (Note 1)	Monitors and displays the room temperature.
	Filter sign	Checks if the filter is clogged and monitors whether or not it can still be used.
	Thermostat status	Monitors whether or not the air conditioner is properly controlling the temperature.
	Compressor status	Monitors if the compressor of the outdoor unit connected to the indoor unit is properly operating.
	Indoor fan status	Monitors if the indoor unit's fan is properly operating.
	Heater operation status	Monitors if the indoor unit's heater is properly operating.
	Ventilation mode status	Monitors the ventilation mode status of the Heat Reclaim Ventilator.
	Ventilation amount status	Monitors the ventilation amount status of the Heat Reclaim Ventilator.
	Accumulated power	Outputs indoor unit's accumulated power consumption.
	Operation, configuration, and monitoring	Start/stop operation (Note 2)
Air-conditioning mode setting (Note 2)		Sets the cooling/heating/ventilating/auto/dry air-conditioning mode and monitors the result.
Room temperature setting (Note 2)		Sets the room temperature of the air conditioner and monitors the result.
Filter sign and reset		Checks if the filter is clogged and resets the status as required.
Remote controller enable/disable		Enables or disables the remote controller so that it can or cannot be used to control the air conditioner's start/stop/air-conditioning mode/room temperature.
Lower central device operation enable/disable		Enables or disables operation of a central device connected to the D III network.
Airflow rate setting (Note 2)		Sets the airflow rate and monitors the result.
Air direction setting (Note 2)		Sets the air direction and monitors the result.
Forced system stop		In response to the forced stop command, checks whether clearance or setting is required and performs the required action.
Forced thermostat disable		In response to the forced thermostat disable command, checks whether clearance or setting is required and performs the required action.
Energy saving		In response to the energy saving command, checks whether clearance or setting is required and performs the required action.
Ventilation mode setting		Sets the ventilation mode and monitors the result.
Ventilation amount setting		Sets the ventilation amount and monitors the result.

Note:

1. The room temperature is measured with the suction air. Since the indoor unit fan stops when the thermostat is disabled or the air conditioner is stopped, or in a special operation such as defrosting, temperature measurement may be affected by the heat exchanger, and may detect and transmit a different temperature from the actual room temperature.

For this reason, this value should be considered as a reference for the room temperature.

If the building management system manufacturer uses this value for system control (e.g., switching the air-conditioning mode or preset temperature), the manufacturer must take on the whole responsibility.

2. The air conditioner saves the settings for the temperature, start/stop status, air-conditioning mode, air direction, and air flow rate in the nonvolatile memory each time they are changed, so that the settings will not be lost when a power cut occurs.

This nonvolatile memory has a write count limit and may cause a failure if it is written exceeding the limit count. Therefore when the temperature, start/stop status, air-conditioning mode, air direction, and airflow rate of each indoor unit are automatically controlled from the central monitoring panel, be sure that the number of changes for each setting **should not exceed 7,000 times per year.**

CB07A004G

1.10.2 Major Functions of Air Conditioner Devices (Incl. Adaptors) to be Connected

Supported models include the VRV System, SkyAir, Heat Reclaim Ventilator, Outdoor air processing unit, Industrial-use air conditioner, Wiring adaptor for other air conditioner and Split. The table below lists the air conditioner items that can be monitored and controlled for each model.

Function	VRV System	SkyAir (interface adaptor for SkyAir series)	Heat Reclaim Ventilator	Outdoor air processing unit	Industrial-use air conditioner (central control adaptor)	Wiring adaptor for other air conditioner	Split (KRP928)
Start/stop operation and monitoring	○	○	○	○	○	○	○
Air conditioner malfunction notification	○	○	○	○	○	○	○
Room temperature monitoring	○	○	×	○ (Suction temperature)	○	×	○
Temperature setting and monitoring	○	○	×	×	○	×	△ (Note3) (Note6)
Air-conditioning mode setting and monitoring	○	○	×	○	○	×	△ (Note4)
Remote-control mode setting and monitoring	○	○	○	○	○	×	△ (Note5)
Filter sign monitoring and reset	○	○	○	○	×	×	×
Thermostat status monitoring	○	○	×	○	×	×	×
Compressor operation status monitoring	○	○	×	○	×	×	×
Indoor fan operation status monitoring	○	○	○	○	×	×	×
Heater operation status monitoring	○	○	×	○	×	×	×
Air direction setting and monitoring	○	○	×	×	×	×	×
Airflow rate setting and monitoring	○	○	△ (Monitoring only)	×	×	×	×
Forced thermostat disable setting and monitoring	○ (Note1)	○	×	○	×	×	×
Energy saving (set temperature shift)	○	×	×	×	×	×	×
Accumulated power	○	△ (Note2)	△ (Note2)	△ (Note2)	×	×	×
Ventilation Mode	×	×	○	×	×	×	×
Ventilation Amount	×	×	○	×	×	×	×

Note:

1. Notification is not sent to the upper devices if the setting was made from the remote control unit. Therefore, monitoring from the upper devices is not possible.
2. Supported by certain models only.
3. If the operating mode is Auto, the set temperature cannot be changed.
4. Fan, Dry, and Auto are not supported.
5. The remote-control mode setting of Split is follow the list in below.

S1 terminal operation mode	Operation prohibit setting from central monitoring panel			Operation from remote controller			
	Start/stop	Operating mode	Temp. setting	Operation timer	Stop	Operating mode, room temp. adjustment	Air direction, airflow rate
Instantaneous contact mode, normally contact mode	Prohibited	Permitted	Permitted	×	×	○	○
			Prohibited	×	×	○	
		Prohibited	Permitted	×	×	×	
			Prohibited	×	×	×	
Instantaneous contact mode	Permitted	Permitted	Permitted	○	○	○	
			Prohibited	○	○	○	
		Prohibited	Permitted	×	○	×	
			Prohibited	×	○	×	
Normally contact mode	Permitted	Permitted	Permitted	×	×	○	
			Prohibited	×	×	○	
		Prohibited	Permitted	×	×	×	
			Prohibited	×	×	×	
Forced stop	Unrelated to settings			×	×	×	×

○ : Operation is possible.
 × : Operation is not possible

6. The Split have varied available ranges of set temperatures depending on the model. In the event a value outside the available ranges of set temperatures is commanded from the central monitoring panel, the air conditioner will not operate under the commanded set temperature.

When commanding the minimum or maximum set temperature to the Split from the central monitoring panel, first check the minimum or maximum value of the corresponding Split within the product catalog or the instruction manual before commanding the set temperature.

Even within the available ranges of set temperatures, In the event the only value "61°F" for set temperatures is commanded from the central monitoring panel, the return value from the air conditioner is "60°F". Therefore when the set temperature is automatically controlled from the central monitoring panel, do not keep commanding the set temperature until the commanded value matches the return value.

1.11 Backup Systems for Troubles

1.11.1 Failure in the System and its Backup Operation

No.	Place of failure					Scope of influence by failure (Note 1.)	Operation when failure occurs. (description of backup)
	BMS	Interface for use in BACnet®	Central remote controller	Local remote controller	Air-conditioning unit		
1	○	○	○	○	×	Corresponding air-conditioning unit	Corresponding air-conditioning unit is shut-down. The details of failure is converted into code and transferred to BMS by the status change notification system. The contents of failure is displayed on local remote controller or central remote controller.
2	○	○	○	×	○	(Corresponding group)	Operation, setting and monitoring is not possible by local remote controller. Disconnect the power of the indoor unit once and turn the power on again, so that the backup operation is carried out by central remote controller.
3	○	○	×	○	○	(Corresponding system)	Operation, setting and monitoring is not possible by the central remote controller. The backup operation is carried out by BMS or local remote controller.
4	○	○	○	○	○	(Corresponding system)	Operation, setting and monitoring is not possible by BMS. Central remote controller and local remote controller can backup the operation.
5	○	×	○	○	○	(Corresponding system)	Operation, setting and monitoring is not possible by BMS. Central remote controller and local remote controller can backup the operation.
6	×	○	○	○	○	(Entire system)	Operation, setting and monitoring is not possible by BMS. Central remote controller and local remote controller can backup the operation.
7	○	○	×	×	○	(Corresponding system)	Operation, setting and monitoring is not possible by central remote controller and local remote controller. Disconnect the power of the indoor unit once and turn the power on again, so that the backup operation is carried out by central remote controller.
8	○	○	×	○	○	(Corresponding system)	Operation, setting and monitoring is not possible by BMS and the central remote controller. The backup operation is carried out by local remote controller.
9	Communication line between indoor unit and local remote controller is shorted or disconnected.					(Corresponding group)	Operation, setting and monitoring is not possible by local remote controller. Disconnect the power of the indoor unit once and turn the power on again, so that the backup operation is carried out by central remote controller.
10	Communication line between Interface for use in BACnet® and indoor unit is shorted or disconnected.					(Corresponding system)	Operation, setting and monitoring is not possible by BMS and the central remote controller. The backup operation is carried out by local remote controller.
11	Communication line between Interface for use in BACnet® is shorted or disconnected.					(Entire system)	Operation, setting and monitoring is not possible by BMS. Central remote controller and local remote controller can backup the operation.

Note:

- () indicates that backup operation of all or part of functions within the scope of influence by equipment failure is possible.
 “Corresponding group” is a group of air conditioner controlled by local remote controller, where the failure is occurred.
 “Corresponding system” is a group of air conditioner controlled by Interface for use in BACnet®, where the failure is occurred.
- The chance that all local remote controllers and Interface for use in BACnet® becomes out of order is almost negligible, so that the case is not included in the above.

1.12 BMS (Building Management System)

Connecting with BMS, versatile system development can be achieved.

■ System architecture

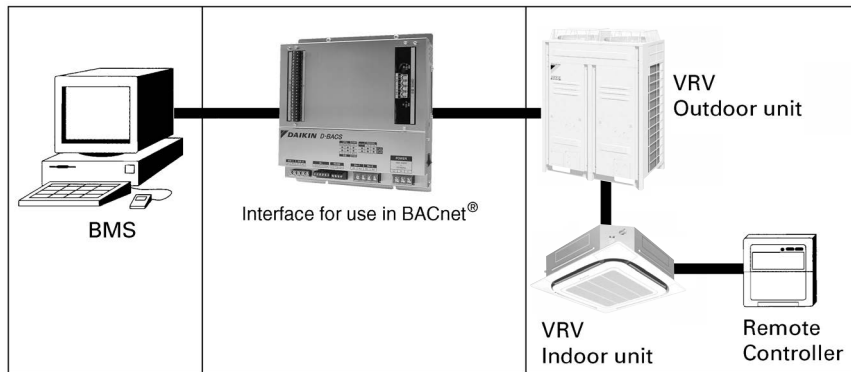

1.13 Adopting “Super Wiring System”

■ In case of (10HP) x2 system

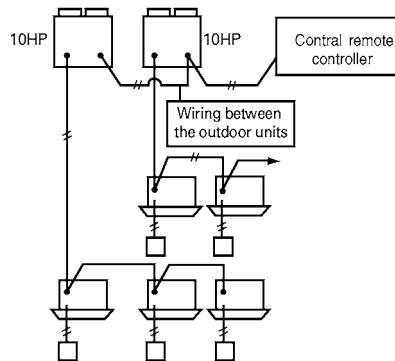

This system reduces the number of wiring by integrating the control wiring between indoor and outdoor unit and the transmission wiring to central remote controller into one common wiring.

Part 2

Functional Specifications

1. Introduction	19
2. Network Topology	19
3. Air Conditioner Monitor/Control Items	20
4. Supported Models and Monitor/Control Items.....	21
5. BACnet [®] Protocol Implementation Conformance Statement (PICS)	22
6. BACnet [®] Interoperability Building Blocks Supported (BIBBs).....	23
6.1 Data Sharing BIBBs	23
6.2 Alarm and Event Management BIBBs.....	23
6.3 SCHEDuling BIBBs	24
6.4 Trending BIBBs	24
6.5 Device Management BIBBs	24
6.6 Network Management BIBBs	25
7. Objects	26
7.1 Supported Object Type	26
7.2 Member Objects	27
8. Properties.....	32
8.1 Accumulator Object Type	32
8.2 Analog Input Object Type.....	33
8.3 Analog Value Object Type.....	35
8.4 Binary Input Object Type (Supported Intrinsic Reporting).....	36
8.5 Binary Input Object Type (Non-supported Intrinsic Reporting).....	37
8.6 Binary Output Object Type	39
8.7 Binary Value Object Type.....	40
8.8 Device Object Type	42
8.9 Multi-state Input Object Type	43
8.10 Multi-state Output Object Type.....	44
9. Report Function.....	45
9.1 COV Notification.....	45
9.2 Event Notification	46
10. Error Response in BACnet [®] Communication.....	48
11. Detailed Description of Objects.....	49
11.1 Common to All Objects.....	49
11.2 Start/Stop (Setting).....	50
11.3 Start/Stop (Status).....	50
11.4 Alarm	51
11.5 Malfunction Code	51
11.6 Air-conditioning Mode (Setting)	52
11.7 Air-conditioning Mode (Status)	52
11.8 Airflow Rate Level (Setting).....	53
11.9 Airflow Rate Level (Status).....	53
11.10 Measured Room Temperature.....	54
11.11 Set Room Temperature	55

11.12	Filter Sign Signal.....	56
11.13	Filter Sign Signal Reset	56
11.14	Remote Controller Enable/Disable (Start/Stop)	57
11.15	Remote Controller Enable/Disable (Air-conditioning Mode)	57
11.16	Remote Controller Enable/Disable (Set Temperature)	57
11.17	Central Control (Lower Central Control Disable)	58
11.18	Accumulated Power.....	58
11.19	Communication Status.....	59
11.20	Forced System Stop	59
11.21	Air Direction (Setting).....	60
11.22	Air Direction (Status).....	60
11.23	Forced Thermostat Disable (Setting).....	61
11.24	Forced Thermostat Disable (Status).....	61
11.25	Energy Saving (Setting).....	61
11.26	Energy Saving (Status).....	61
11.27	Thermostat Status	62
11.28	Compressor Status	62
11.29	Indoor Fan Status	62
11.30	Heater Operation Status	62
11.31	Ventilation Mode (Setting)	63
11.32	Ventilation Mode (Status)	63
11.33	Ventilation Amount (Setting)	64
11.34	Ventilation Amount (Status)	64
12.	Others	65
12.1	Initial Status at Start-up	65
12.2	BACnet [®] Network Layer.....	65
12.3	Time Adjustment	65
12.4	Device Communication Control Service.....	65
13.	Appendix A: PICS	
	(D-BACS Interface for use in BACnet [®] Ver. 6.10)	67
13.1	BACnet [®] Protocol Implementation Conformance Statement	67
14.	Appendix B: PICS	
	(D-BACS Interface for use in BACnet [®] Ver. 6.20)	73
14.1	BACnet [®] Protocol Implementation Conformance Statement	73
15.	Appendix C: PICS	
	(D-BACS Interface for use in BACnet [®] Ver. 6.30)	79
15.1	BACnet [®] Protocol Implementation Conformance Statement	79

1. Introduction

The D-BACS Interface for use in BACnet® (Japanese version: MasterStation III) operates as the BACnet® server that uses the services defined by the BACnet® to return the status of the air conditioners connected to the D III network as well as to receive configuration commands to them, in response to requests from a central monitoring device (i.e., BACnet® client) which support the BACnet® (ISO16484-5, ANSI/ASHRAE135) protocol.

2. Network Topology

Any BACnet® client which supports the BACnet® (ISO16484-5, ANSI/ASHRAE135) protocol can be directly connected to the network via a general Ethernet hub, as illustrated below.

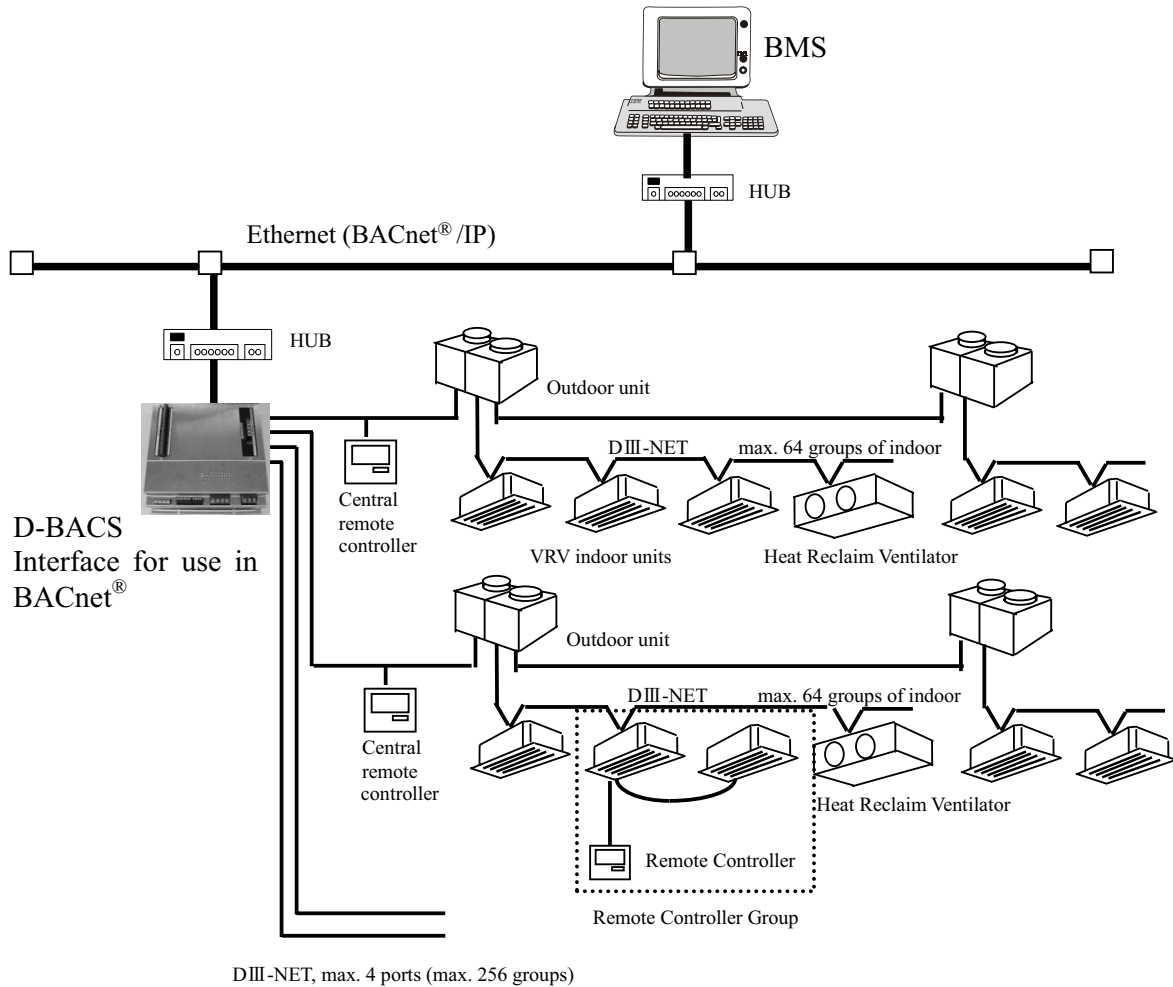

The Data Link Layer options support the BACnet® /IP protocol.

CB07A004G

3. Air Conditioner Monitor/Control Items

The table below lists the air conditioner items that can be monitored and controlled via the BACnet communication.

	Function	Description
Monitor	Start/stop status	Monitors the start/stop status of the air conditioner.
	Alarm	Monitors whether or not the air conditioner is operating normally, and issues an alarm if the air conditioner has a malfunction.
	Malfunction code	Displays a malfunction code specified by the manufacturer if an air conditioner in the system has a malfunction.
	Air-conditioning mode	Monitors if the air conditioner is cooling, heating, ventilating or dry.
	Room temperature (Note 1)	Monitors and displays the room temperature.
	Filter sign	Checks if the filter is clogged and monitors whether or not it can still be used.
	Thermostat status	Monitors whether or not the air conditioner is properly controlling the temperature.
	Compressor status	Monitors if the compressor of the outdoor unit connected to the indoor unit is properly operating.
	Indoor fan status	Monitors if the indoor unit's fan is properly operating.
	Heater operation status	Monitors if the indoor unit's heater is properly operating.
	Ventilation mode status	Monitors the ventilation mode status of the Heat Reclaim Ventilator.
	Ventilation amount status	Monitors the ventilation amount status of the Heat Reclaim Ventilator.
	Accumulated power	Outputs indoor unit's accumulated power consumption.
	Operation, configuration, and monitoring	Start/stop operation (Note 2)
Air-conditioning mode setting (Note 2)		Sets the cooling/heating/ventilating/auto/dry air-conditioning mode and monitors the result.
Room temperature setting (Note 2)		Sets the room temperature of the air conditioner and monitors the result.
Filter sign and reset		Checks if the filter is clogged and resets the status as required.
Remote controller enable/disable		Enables or disables the remote controller so that it can or cannot be used to control the air conditioner's start/stop/air-conditioning mode/room temperature.
Lower central device operation enable/disable		Enables or disables operation of a central device connected to the D III network.
Airflow rate setting (Note 2)		Sets the airflow rate and monitors the result.
Air direction setting (Note 2)		Sets the air direction and monitors the result.
Forced system stop		In response to the forced stop command, checks whether clearance or setting is required and performs the required action.
Forced thermostat disable		In response to the forced thermostat disable command, checks whether clearance or setting is required and performs the required action.
Energy saving		In response to the energy saving command, checks whether clearance or setting is required and performs the required action.
Ventilation mode setting		Sets the ventilation mode and monitors the result.
Ventilation amount setting		Sets the ventilation amount and monitors the result.

(Note 1) The room temperature is measured with the suction air. Since the indoor unit fan stops when the thermostat is disabled or the air conditioner is stopped, or in a special operation such as defrosting, temperature measurement may be affected by the heat exchanger, and may detect and transmit a different temperature from the actual room temperature.

For this reason, this value should be considered as a reference for the room temperature.

If the building management system manufacturer uses this value for system control (e.g., switching the air-conditioning mode or preset temperature), the manufacturer must take on the whole responsibility.

(Note 2) The air conditioner saves the settings for the temperature, start/stop status, air-conditioning mode, air direction, and air flow rate in the nonvolatile memory each time they are changed, so that the settings will not be lost when a power cut occurs.

This nonvolatile memory has a write count limit and may cause a failure if it is written exceeding the limit count.

Therefore when the temperature, start/stop status, air-conditioning mode, air direction, and airflow rate of each indoor unit are automatically controlled from the central monitoring panel, be sure that the number of changes for each setting **should not exceed 7,000 times per year.**

4. Supported Models and Monitor/Control Items

Supported models include the VRV System, SkyAir, Heat Reclaim Ventilator, Outdoor air processing unit, Industrial-use air conditioner, Wiring adaptor for other air conditioner and Split. The table below lists the air conditioner items that can be monitored and controlled for each model.

Function	VRV System	SkyAir (interface adaptor for SkyAir series)	Heat Reclaim Ventilator	Outdoor air processing unit	Industrial-use air conditioner (central control adaptor)	Wiring adaptor for other air conditioner	Split (KRP928)
Start/stop operation and monitoring	○	○	○	○	○	○	○
Air conditioner malfunction notification	○	○	○	○	○	○	○
Room temperature monitoring	○	○	×	○ (Suction temperature)	○	×	○
Temperature setting and monitoring	○	○	×	×	○	×	△ (Note3) (Note6)
Air-conditioning mode setting and monitoring	○	○	×	○56	○	×	△ (Note4)
Remote-control mode setting and monitoring	○	○	○	○	○	×	△ (Note5)
Filter sign monitoring and reset	○	○	○	○	×	×	×
Thermostat status monitoring	○	○	×	○	×	×	×
Compressor operation status monitoring	○	○	×	○	×	×	×
Indoor fan operation status monitoring	○	○	○	○	×	×	×
Heater operation status monitoring	○	○	×	○	×	×	×
Air direction setting and monitoring	○	○	×	×	×	×	×
Airflow rate setting and monitoring	○	○	△ (Monitoring only)	×	×	×	×
Forced thermostat disable setting and monitoring	○ (Note1)	○	×	○	×	×	×
Energy saving (set temperature shift)	○	×	×	×	×	×	×
Accumulated power	○	△ (Note2)	△ (Note2)	△ (Note2)	×	×	×
Ventilation Mode	×	×	○ (Note7)	×	×	×	×
Ventilation Amount	×	×	○ (Note7)	×	×	×	×

- Notes) 1. Notification is not sent to the upper devices if the setting was made from the remote control unit. Therefore, monitoring from the upper devices is not possible.
 2. Supported by certain models only.
 3. If the operating mode is Auto, the set temperature cannot be changed.
 4. Fan, Dry, and Auto are not supported.
 5. The remote-control mode setting of Split is follow the list in below.

S1 terminal operation mode	Operation prohibit setting from central monitoring panel			Operation from remote controller			
	Start/stop	Operating mode	Temp. setting	Operation timer	Stop	Operating mode, room temp. adjustment	Air direction, airflow rate
Instantaneous contact mode, normally contact mode	Prohibited	Permitted	Permitted	×	×	○	○
			Prohibited	×	×	○	
		Prohibited	Permitted	×	×	×	
			Prohibited	×	×	×	
Instantaneous contact mode	Permitted	Permitted	Permitted	○	○	○	
			Prohibited	×	○	×	
		Prohibited	Permitted	×	○	×	
			Prohibited	×	○	×	
Normally contact mode	Permitted	Permitted	Permitted	×	×	○	
			Prohibited	×	×	○	
		Prohibited	Permitted	×	×	×	
			Prohibited	×	×	×	
Forced stop	Unrelated to settings			×	×	×	×

○ : Operation is possible.

× : Operation is not possible

CB07A004G

- Notes) 6. The Split have varied available ranges of set temperatures depending on the model.
In the event a value outside the available ranges of set temperature is commanded from the central monitoring panel, the air conditioner will not operate under the commanded set temperature.
- When commanding the minimum or maximum set temperature to the Split from the central monitoring panel, first check the minimum or maximum value of the corresponding Split within the product catalog or the instruction manual before commanding the set temperature.
- Even within the available ranges of set temperatures, in the event the only value “61°F” for set temperatures is commanded from the central monitoring panel, the return value from the air conditioner is “60°F”. Therefore when the set temperature is automatically controlled from the central monitoring panel, do not keep commanding the set temperature until the commanded value matches the return value.
7. Supported by later the GA type models.

5. BACnet® Protocol Implementation Conformance Statement (PICS)

Refer to the appendices.

CB07A004G

6. BACnet® Interoperability Building Blocks Supported (BIBBs)

6.1 Data Sharing BIBBs

BIBB Type		Supported	BACnet® Service	Initiate	Execute
DS-RP-A	Data Sharing-ReadProperty-A	<input type="checkbox"/>	ReadProperty	X	
DS-RP-B	Data Sharing-ReadProperty-B	<input checked="" type="checkbox"/>	ReadProperty		X
DS-RPM-A	Data Sharing-ReadPropertyMultiple-A	<input type="checkbox"/>	ReadPropertyMultiple	X	
DS-RPM-B	Data Sharing-ReadPropertyMultiple-B	<input checked="" type="checkbox"/>	ReadPropertyMultiple		X
DS-RPC-A	Data Sharing-ReadPropertyConditiona-A	<input type="checkbox"/>	ReadPropertyConditional	X	
DS-RPC-B	Data Sharing-ReadPropertyConditional-B	<input type="checkbox"/>	ReadPropertyConditional		X
DS-WP-A	Data Sharing-WriteProperty-A	<input type="checkbox"/>	WriteProperty	X	
DS-WP-B	Data Sharing-WriteProperty-B	<input checked="" type="checkbox"/>	WriteProperty		X
DS-WPM-A	Data Sharing-WritePropertyMultiple-A	<input type="checkbox"/>	WritePropertyMultiple	X	
DS-WPM-B	Data Sharing-WritePropertyMultiple-B	<input checked="" type="checkbox"/>	WritePropertyMultiple		X
DS-COV-A	Data Sharing-COV-A	<input type="checkbox"/>	SubscribeCOV	X	
			ConfirmedCOVNotification		X
			UnconfirmedCOVNotification		X
DS-COV-B	Data Sharing-COV-B	<input checked="" type="checkbox"/>	SubscribeCOV		X
			ConfirmedCOVNotification	X	
			UnconfirmedCOVNotification	X	
DS-COVP-A	Data Sharing-COVP-A	<input type="checkbox"/>	SubscribeCOV	X	
			ConfirmedCOVNotification		X
			UnconfirmedCOVNotification		X
DS-COVP-B	Data Sharing-COVP-B	<input type="checkbox"/>	SubscribeCOV		X
			ConfirmedCOVNotification	X	
			UnconfirmedCOVNotification	X	
DS-COVU-A	Data Sharing-COV-Unsolicited-A	<input type="checkbox"/>	UnconfirmedCOVNotification		X
DS-COVU-B	Data Sharing-COV-UnsolicitedvB	<input checked="" type="checkbox"/>	UnconfirmedCOVNotification	X	

6.2 Alarm and Event Management BIBBs

BIBB Type		Supported	BACnet® Service	Initiate	Execute
AE-N-A	Alarm and Event-Notification-A	<input type="checkbox"/>	ConfirmedEventNotification		X
			UnconfirmedEventNotification		X
AE-N-I-B	Alarm and Event-Notification Internal-B	<input checked="" type="checkbox"/>	ConfirmedEventNotification	X	
			UnconfirmedEventNotification	X	
AE-N-E-B	Alarm and Event-Notification External-B	<input type="checkbox"/>	ConfirmedEventNotification	X	
			UnconfirmedEventNotification	X	
AE-ACK-A	Alarm and Event-ACK-A	<input type="checkbox"/>	AcknowledgeAlarm	X	
AE-ACK-B	Alarm and Event-ACK-B	<input type="checkbox"/>	AcknowledgeAlarm		X
AE-ASUM-A	Alarm and Event-Summary-A	<input type="checkbox"/>	GetAlarmSummary	X	
AE-ASUM-B	Alarm and Event-Summary-B	<input type="checkbox"/>	GetAlarmSummary		X
AE-ESUM-A	Event-Summary-A	<input type="checkbox"/>	GetEnrollmentSummary	X	
AE-ESUM-B	Event-Summary-B	<input type="checkbox"/>	GetEnrollmentSummary		X
AE-INFO-A	Alarm and Event-Information-A	<input type="checkbox"/>	GetEventInformation	X	
AE-INFO-B	Alarm and Event-Information-B	<input type="checkbox"/>	GetEventInformation		X
AE-LS-A	Alarm and Event-LifeSafety-A	<input type="checkbox"/>	LifeSafetyOperation	X	
AE-LS-B	Alarm and Event-LifeSafety-B	<input type="checkbox"/>	LifeSafetyOperation		X

CB07A004G

6.3 SCHEDuling BIBBs

BIBB Type		Supported	BACnet® Service	Initiate	Execute
SCHED-A	Scheduling–A	<input type="checkbox"/>			
	<i>(must support DS-RP-A and DS-WP-A)</i>				
SCHED-I-B	Scheduling-Internal–B	<input type="checkbox"/>			
	<i>(shall support DS-RP-B and DS-WP-B)</i>				
	<i>(shall also support ether DM-TS-B or DS-UTC-B)</i>				
SCHED-E-B	Scheduling-External–B	<input type="checkbox"/>			
	<i>(shall support SCHED-I-B and DS-WP-A)</i>				

6.4 Trending BIBBs

BIBB Type		Supported	BACnet® Service	Initiate	Execute
T-VMT-A	Trending - Viewing and Modifying Trends–A	<input type="checkbox"/>	ReadRange	X	
T-VMT-I-B	Trending - Viewing and Modifying Trends Internal–B	<input type="checkbox"/>	ReadRange		X
T-VMT-E-B	Trending - Viewing and Modifying Trends External–B	<input type="checkbox"/>	ReadRange		X
T-ATR-A	Trending - Automated Trend Retrieval–A	<input type="checkbox"/>	ConfirmedEventNotification		X
			ReadRange	X	
T-ATR-B	Trending - Automated Trend Retrieval–B	<input type="checkbox"/>	ConfirmedEventNotification	X	
			ReadRange		X

6.5 Device Management BIBBs

BIBB Type		Supported	BACnet® Service	Initiate	Execute
DM-DDB-A	Device Management - Dynamic Device Binding–A	<input checked="" type="checkbox"/>	Who-Is	X	
			I-Am		X
DM-DDB-B	Device Management - Dynamic Device Binding–B	<input checked="" type="checkbox"/>	Who-Is		X
			I-Am	X	
DM-DOB-A	Device Management - Dynamic Object Binding–A	<input type="checkbox"/>	Who-Has	X	
			I-Have		X
DM-DOB-B	Device Management - Dynamic Object Binding–B	<input checked="" type="checkbox"/>	Who-Has		X
			I-Have	X	
DM-DCC-A	Device Management - DeviceCommunicationControl–A	<input type="checkbox"/>	DeviceCommunicationControl	X	
DM-DCC-B	Device Management - DeviceCommunicationControl–B	<input checked="" type="checkbox"/>	DeviceCommunicationControl		X
DM-PT-A	Device Management - PrivateTransfer–A	<input type="checkbox"/>	ConfirmedPrivateTransfer	X	
			UnconfirmedPrivateTransfer	X	
DM-PT-B	Device Management - PrivateTransfer–B	<input type="checkbox"/>	ConfirmedPrivateTransfer		X
			UnconfirmedPrivateTransfer		X
DM-TM-A	Device Management - Text Message–A	<input type="checkbox"/>	ConfirmedTextMessage	X	
			UnconfirmedTextMessage	X	
DM-TM-B	Device Management - Text Message–B	<input type="checkbox"/>	ConfirmedTextMessage		X
			UnconfirmedTextMessage		X
DM-TS-A	Device Management - TimeSynchronization–A	<input type="checkbox"/>	TimeSynchronization	X	
DM-TS-B	Device Management - TimeSynchronization–B	<input checked="" type="checkbox"/>	TimeSynchronization		X
DM-UTC-A	Device Management - UTCTimeSynchronization–A	<input type="checkbox"/>	UTCTimeSynchronization	X	
DM-UTC-B	Device Management - UTCTimeSynchronization–B	<input checked="" type="checkbox"/>	UTCTimeSynchronization		X
DM-RD-A	Device Management - ReinitializeDevice–A	<input type="checkbox"/>	ReinitializeDevice	X	
DM-RD-B	Device Management - ReinitializeDevice–B	<input type="checkbox"/>	ReinitializeDevice		X
DM-BR-A	Device Management - Backup and Restore–A	<input type="checkbox"/>	AtomicReadFile	X	
			AtomicWriteFile	X	
			CreateObject	X	
			ReinitializeDevice	X	

CB07A004G

DM-BR-B	Device Management - Backup and Restore-B	<input type="checkbox"/>	AtomicReadFile		X
			AtomicWriteFile		X
			ReinitializeDevice		X
DM-R-A	Device Management - Restart-A	<input type="checkbox"/>	UnconfirmedCOVNotification		X
DM-R-B	Device Management - Restart-B	<input type="checkbox"/>	UnconfirmedCOVNotification	X	
DM-LM-A	Device Management - List Manipulation-A	<input type="checkbox"/>	AddListElement	X	
			RemoveListElement	X	
DM-LM-B	Device Management - List Manipulation-B	<input type="checkbox"/>	AddListElement		X
			RemoveListElement		X
DM-OCD-A	Device Management - Object Creation and Deletion-A	<input type="checkbox"/>	CreateObject	X	
			DeleteObject	X	
DM-OCD-B	Device Management - Object Creation and Deletion-B	<input type="checkbox"/>	CreateObject		X
			DeleteObject		X
DM-VT-A	Device Management - Virtual Terminal-A	<input type="checkbox"/>	VT-Open	X	
			VT-Close	X	X
			VT-Data	X	X
DM-VT-B	Device Management - Virtual Terminal-B	<input type="checkbox"/>	VT-Open		X
			VT-Close	X	X
			VT-Data	X	X

6.6 Network Management BIBBs

BIBB Type		Supported	BACnet® Network Layer Message	Initiate	Execute
NM-CE-A	Network Management - Connection Establishment-A	<input type="checkbox"/>	Establish-Connection-To-Network	X	
			Disconnect-Connection-To-Network	X	
NM-CE-B	Network Management - Connection Establishment-B	<input type="checkbox"/>	Establish-Connection-To-Network		X
			Disconnect-Connection-To-Network		X
NM-RC-A	Network Management - Router Configuration-A	<input type="checkbox"/>	Who-Is-Router-To-Network	X	
			I-Am-Router-To-Network		X
			I-Could-Be-Router-To-Network		X
			Initialize-Routing-Table	X	
			Initialize-Routing-Table-Ack		X
NM-RC-B	Network Management - Router Configuration-B	<input type="checkbox"/>	Who-Is-Router-To-Network	X	X
			I-Am-Router-To-Network	X	X
			Initialize-Routing-Table		X
			Initialize-Routing-Table-Ack	X	

CB07A004G

7. Objects

7.1 Supported Object Type

Supported air conditioner monitoring/control items are mapped to the standard object types defined by the BACnet[®], as listed below.

Object Type	Supported	Air conditioner management point
Accumulator 23	■	Accumulated power, accumulated gas
Analog-Input 0	■	Measured room temperature, air direction level (status)
Analog-Output 1	■	
Analog-Value 2	■	Set room temperature, air direction level (setting)
Averaging 18	□	
Binary-Input 3	■	Start/stop (status), alarm, filter sign status, forced thermostat disable (status), energy saving (status), thermostat status, compressor status, indoor fan operation status, heater operation status, communication status
Binary-Output 4	■	Start/stop (setting), forced thermostat disable (setting), energy saving (setting)
Binary-Value 5	■	Filter sign reset, remote controller setting (start/stop /air-conditioning mode/set temperature), lower central control system, forced stop
Calendar 6	□	
Command 7	□	
Device 8	■	
Event-Enrollment 9	□	
File 10	□	
Group 11	□	
Life-Safety-Point 21	□	
Life-Safety-Zone 22	□	
Loop 12	□	
Multistate-Input 13	■	Air-conditioning mode (status), malfunction code, air flow rate level (status) Ventilation Mode(status), Ventilation Amount(status)
Multistate-Output 14	■	Air-conditioning mode (setting), airflow rate level (setting) Ventilation Mode(setting), Ventilation Amount(setting)
Multistate-Value 19	□	
Notification-Class 15	■	Alarm notification recipient information
Program 16	□	
Schedule 17	□	
Trend-Log 20	□	

CB07A004G

7.2 Member Objects

Each air conditioner management point is mapped to the corresponding BACnet® object's instance number. The BACnet® object uses the data field of the instance number 22 as shown below.

31	22	21	16	15	8	7	0
BACnet® object type	Not used (zero)	Air conditioner number	Member number				

The air conditioner number represents the number used by the air conditioner line to manage each air conditioner and the BACnet® clients (HIM and other ICONT devices) use this number to specify the air conditioner. Each member number corresponds to each management item for the air conditioner, as defined in the following object list.

Member number	Standard name	Object name (XXX represents the air conditioner number.)	Object type	Unit				
				Inactive	Active	Text-1	Text-2	Text-3
1	Start/stop (setting) (Note 2)	StartStopCommand_XXX	BO	Stop	Operation			
2	Start/stop (status)	StartStopStatus_XXX	BI	Stop	Operation			
3	Alarm	Alarm_XXX	BI	Normal	Malfunction			
4	Malfunction code addition	MalfunctionCode_XXX	MI	Normal	Manufacturer specific			
5	Air-conditioning mode (setting) (Note 2) (Note 3)	AirConModeCommand_XXX	MO	Cooling	Heating	Fan	Auto	Dry
6	Air-conditioning mode (status)	AirConModeStatus_XXX	MI	Cooling	Heating	Fan	(Not used)	Dry
7	Air flow rate level (setting) (Note 2)	AirFlowRateCommand_XXX	MO	Low	High	Middle	Auto	
8	Air flow rate level (status)	AirFlowRateStatus_XXX	MI	Low	High	Middle	Auto	
9	Measured room temperature (Note 1)	RoomTemp_XXX	AI	°C/°F				
10	Set room temperature (Note 2)	TempAdjust_XXX	AV	°C/°F				
11	Filter sign signal	FilterSign_XXX	BI	No	Yes			
12	Filter sign signal reset	FilterSignReset_XXX	BV	Reset				
13	Remote controller enable/disable (start/stop)	RemoteControlStart_XXX	BV	Enabled	Disabled			
14	Remote controller enable/disable (air-conditioning mode)	RemoteControlAirConModeSet_XXX	BV	Enabled	Disabled			
15	Blank							
16	Remote controller enable/disable (set temperature)	RemoteControlTempAdjust_XXX	BV	Enabled	Disabled			
(*17)	Central control (lower central control disable)	CL_Rejection_XXX	BV	Enabled	Disabled			
18	Accumulated gas (Note 4)	Gas TotalPower_XXX	Accu- mulator	m3				
19	Accumulated power	ElecTotalPower_XXX	Accu- mulator	kWh				
20	Communication status	CommunicationStatus_XXX	BI	Normal communication	Communication error			
(*21)	Forced system stop	SystemForcedOff_XXX	BV	Clearance	Forced stop			
22	Air direction (setting) (Note 2)	AirDirectionCommand_XXX	AV					
23	Air direction (status)	AirDirectionStatus_XXX	AI					
24	Forced thermostat disable (setting)	ForcedThermoOFFCommand_XXX	BO	Clearance	Set			
25	Forced thermostat disable (status)	ForcedThermoOFFStatus_XXX	BI	Clearance	Set			
26	Energy saving (setting)	EnergyEfficiencyCommand_XXX	BO	Clearance	Set			
27	Energy saving (status)	EnergyEfficiencyStatus_XXX	BI	Clearance	Set			
28	Thermostat status	ThermoStatus_XXX	BI	OFF	ON			
29	Compressor status	CompressorStatus_XXX	BI	Stop	Operation			
30	Indoor fan status	IndoorFanStatus_XXX	BI	Stop	Operation			
31	Heater operation status	HeaterStatus_XXX	BI	Stop	Operation			

CB07A004G

Member number	Standard name	Object name (XXX represents the air conditioner number.)	Object type	Unit					
				Inactive	Active				
				Text-1	Text-2	Text-3	Text-4	Text-5	Text-6
32	Ventilation Mode (setting)	VentilationModeCommand_XXX	MO	Bypass	ER Ventilation	Auto			
33	VentilationMode (status)	VentilationModeStatus_XXX	MI	Bypass	ERVentilation	Auto			
34	VentilationAmount (setting)	VentilationAmountCommand_XXX	MO	Low	High	Auto	Low (fresh up)	High (fresh up)	Auto (fresh up)
35	VentilationAmount (status)	VentilationAmountStatus_XXX	MI	Low	High	Auto	Low (fresh up)	High (fresh up)	Auto (fresh up)

Central control (lower central control disable) and forced system stop are only available for 000, 064, 128, and 192

(Note 1) The room temperature is measured with the suction air. Since the indoor unit fan stops when the thermostat is disabled or the air conditioner is stopped, or in a special operation such as defrosting, temperature measurement may be affected by the heat exchanger, and may detect and transmit a different temperature from the actual room temperature. For this reason, this value should be considered as a reference for the room temperature.

If the building management system manufacturer uses this value for system control (e.g., switching the air-conditioning mode or preset temperature), the manufacturer must take on the whole responsibility.

(Note 2) The air conditioner saves the settings for the temperature, start/stop status, air-conditioning mode, air direction, and air flow rate in the nonvolatile memory each time they are changed, so that the settings will not be lost when a power cut occurs. This nonvolatile memory has a write count limit and may cause a failure if it is written exceeding the limit count.

Therefore when the temperature, start/stop status, air-conditioning mode, air direction, and airflow rate of each indoor unit are automatically controlled from the central monitoring panel, be sure that the number of changes for each setting **should not exceed 7,000 times per year.**

(Note 3) If the operation mode is set to "Dry", any indoor unit with no cooling/heating selection right for the same refrigerant system will not change to the "Dry" mode except in the cooling mode.

(Note 4) Member number 18 is for Japanese market only.

CB07A004G

Objects can be mapped to each of the supported models as shown in the table below.

List of Interface for use in BACnet® control item DIII-NET codes

Member number	Standard name	Object name (XXX represents the air conditioner number.)	Object Type	VRV System	SkyAir (interface adapter for SkyAir series)	Heat Reclaim Ventilator	Outdoor air processing unit	Industrial-use air conditioner (central control adapter)	Wiring adapter for other air conditioner	Split (KRP928)
1	Start/stop (setting)	StartStopCommand_XXX	BO	○	○	○	○	○	○	○
2	Start/stop (status)	StartStopStatus_XXX	BI	○	○	○	○	○	○	○
3	Alarm	Alarm_XXX	BI	○	○	○	○	○	○	○
4	Malfunction code	MalfunctionCode_XXX	MI	○	○	○	○	○	○	○
5	Air-conditioning mode (setting)	AirConModeCommand_XXX	MO	○	○	×	○	○	×	△ (Note4)
6	Air-conditioning mode (status)	AirConModeStatus_XXX	MI	○	○	×	○	○	×	△ (Note4)
7	Air flow rate level (setting)	AirFlowRateCommand_XXX	MO	○	○	×	×	×	×	×
8	Air flow rate level (status)	AirFlowRateStatus_XXX	MI	○	○	×	×	×	×	×
9	Measured room temperature	RoomTemp_XXX	AI	○	○	×	○ (Suction temperature)	○	×	○
10	Set room temperature	TempAdjust_XXX	AV	○	○	×	×	○	×	△ (Note3) (Note6)
11	Filter sign signal	FilterSign_XXX	BI	○	○	○	○	×	×	×
12	Filter sign signal reset	FilterSignReset_XXX	BV	○	○	○	○	×	×	×
13	Remote controller enable/disable (start/stop)	RemoteControlStart_XXX	BV	○	○	○	○	○	×	△ (Note5)
14	Remote controller enable/disable (air-conditioning mode)	RemoteControlAirConModeSet_XXX	BV	○	○	○	○	○	×	△ (Note5)
15	Blank			—	—	—	—	—	—	—
16	Remote controller enable/disable (set temperature)	RemoteControlTempAdjust_XXX	BV	○	○	○	○	○	×	△ (Note5)
17	Central control (lower central control disable)	CL_Rejection_XXX	BV	○	○	○	○	○	×	○
18	Blank			—	—	—	—	—	—	—
19	Accumulated power	ElecTotalPower_XXX	Accumulator	○	△ (Note2)	△(Note2)	△ (Note2)	×	×	×
20	Communication status	CommunicationStatus_XXX	BI	○	○	○	○	○	○	○
21	Forced system stop	SystemForcedOff_XXX	BV	○	○	○	○	○	○	○
22	Air direction (setting)	AirDirectionCommand_XXX	AV	○	○	×	×	×	×	×
23	Air direction (status)	AirDirectionStatus_XXX	AI	○	○	×	×	×	×	×
24	Forced thermostat disable (setting)	ForcedThermoOFFCommand_XXX	BO	○	○	×	○	×	×	×
25	Forced thermostat disable (status)	ForcedThermoOFFStatus_XXX	BI	○(Note1)	○	×	○	×	×	×
26	Energy saving (setting)	EnergyEfficiencyCommand_XXX	BO	○	×	×	×	×	×	×
27	Energy saving (status)	EnergyEfficiencyStatus_XXX	BI	○	×	×	×	×	×	×
28	Thermostat status	ThermoStatus_XXX	BI	○	○	×	○	×	×	×
29	Compressor status	CompressorStatus_XXX	BI	○	○	×	○	×	×	×
30	Indoor fan status	IndoorFanStatus_XXX	BI	○	○	○	○	×	×	×
31	Heater operation status	HeaterStatus_XXX	BI	○	○	×	○	×	×	×
32	Ventilation Mode (setting)	VentilationModeCommand_XXX	MO	×	×	○(Note7)	×	×	×	×
33	Ventilation Mode (status)	VentilationModeStatus_XXX	MI	×	×	○(Note7)	×	×	×	×
34	Ventilation Amount (setting)	VentilationAmountCommand_XXX	MO	×	×	○(Note7)	×	×	×	×
35	Ventilation Amount (status)	VentilationAmountStatus_XXX	MI	×	×	○(Note7)	×	×	×	×

Notes) 1. Notification is not sent to the upper devices if the setting was made from the remote control unit.

Therefore, monitoring from the upper devices is not possible.

2. Supported by certain models only.

3. If the operating mode is Auto, the set temperature cannot be changed.

4. Fan, Dry, and Auto are not supported.

5. The remote-control mode setting of Split is follow the list in below. (○: Operation is possible. ×: Operation is not possible)

CB07A004G

S1 terminal operation mode	Operation prohibit setting from central monitoring panel			Operation from remote controller			
	Start/stop	Operating mode	Temp. setting	Operation timer	Stop	Operating mode, room temp. adjustment	Air direction, airflow rate
Instantaneous contact mode, normally contact mode	Prohibited	Permitted	Permitted	×	×	○	○
			Prohibited	×	×	○	
		Prohibited	Permitted	×	×	×	
			Prohibited	×	×	×	
Instantaneous contact mode	Permitted	Permitted	Permitted	○	○	○	
			Prohibited	○	○	○	
		Prohibited	Permitted	×	○	×	
			Prohibited	×	○	×	
Normally contact mode	Permitted	Permitted	Permitted	×	×	○	
			Prohibited	×	×	○	
		Prohibited	Permitted	×	×	×	
			Prohibited	×	×	×	
Forced stop	Unrelated to settings			×	×	×	×

Notes) 6. The Split have varied available ranges of set temperatures depending on the model.
 In the event a value outside the available ranges of set temperatures is commanded from the central monitoring panel, the air conditioner will not operate under the commanded set temperature.

When commanding the minimum or maximum set temperature to the Split from the central monitoring panel, first check the minimum or maximum value of the corresponding Split within the product catalog or the instruction manual before commanding the set temperature.

Even within the available ranges of set temperatures, in the event the only value “61°F” for set temperatures is commanded from the central monitoring panel, the return value from the air conditioner is “60°F”. Therefore when the set temperature is automatically controlled from the central monitoring panel, do not keep commanding the set temperature until the commanded value matches the return value.

7. Supported by later the GA type models.

CB07A004G

Some complicated calculation is required to determine the object IDs for the monitor/control items from the D III addresses of actual air conditioners.

For example, the object ID for the start/stop (setting) object of each air conditioner is calculated as shown below.

	D3 address	Air conditioner number	Object Name	ObjectID		
Unit D3-1	1-00	000	StartStopCommand_000	$BO(4) + 0 * 256 + 1$	$BO + 1$	16777217
	1-01	001	StartStopCommand_001	$BO(4) + 1 * 256 + 1$	$BO + 257$	16777473
	•••	••••	••••••••••••••••	••••••••••••••••	••••••••	••••••••
	4-15	063	StartStopCommand_063	$BO(4) + 63 * 256 + 1$	$BO + 16129$	16793345
Extension D3-2	1-00	064	StartStopCommand_064	$BO(4) + 64 * 256 + 1$	$BO + 16385$	16793601
	1-01	065	StartStopCommand_065	$BO(4) + 65 * 256 + 1$	$BO + 16641$	16793857
	•••	••••	••••••••••••••••	••••••••~	••••••••	••••••••
	4-15	127	StartStopCommand_127	$BO(4) + 127 * 256 + 1$	$BO + 32513$	16809729
Extension D3-3	1-00	128	StartStopCommand_128	$BO(4) + 128 * 256 + 1$	$BO + 32769$	16809985
	1-01	129	StartStopCommand_129	$BO(4) + 129 * 256 + 1$	$BO + 33025$	16810241
	•••	••••	••••~	••••~	••••~	••••~
	4-15	191	StartStopCommand_191	$BO(4) + 191 * 256 + 1$	$BO + 48897$	16826113
Extension D3-4	1-00	192	StartStopCommand_192	$BO(4) + 192 * 256 + 1$	$BO + 49153$	16826369
	1-01	193	StartStopCommand_193	$BO(4) + 193 * 256 + 1$	$BO + 49409$	16826625
	•••	••••	••••~	••••~	••••~	••••~
	4-15	255	StartStopCommand_255	$BO(4) + 255 * 256 + 1$	$BO + 65281$	16842497

As mentioned above, since the object type is represented with the upper 10 bits of 32 bits, the instance number of each object type is calculated as shown below.

Object type	Object number	Hexadecimal format	Decimal format
AI	0	X'0000 0000'	0
AO	1	X'0040 0000'	4,194,304
AV	2	X'0080 0000'	8,388,608
BI	3	X'00C0 0000'	12,582,912
BO	4	X'0100 0000'	16,777,216
BV	5	X'0140 0000'	20,971,520
MI	13	X'0340 0000'	54,525,952
MO	14	X'0380 0000'	58,720,256
Accumulator	23	X'05C0 0000'	96,468,992

CB07A004G

8. Properties

This section lists properties for each object type in separate tables.

Note that properties shown in parentheses are optional and not supported with the standard setting. These properties need to be enabled by our service personnel.

8.1 Accumulator Object Type

Property Identifier	Property Datatype	BACnet®	MS III	Note
Object_Identifier	BACnetObjectIdentifier	R	R	
Object_Name	CharacterString	R	R	
Object_Type	BACnetObjectType	R	R	ACCUMULATOR (23)
Present_Value	Unsigned	R1	R	Integer value in 0.1kWh
Description	CharacterString	O	-	
Device_Type	CharacterString	O	-	
Status_Flags	BACnetStatusFlags	R	R	IN_ALARM (always FALSE) FAULT (TRUE: Communication malfunction) OVERRIDDEN (always FALSE) OUT_OF_SERVICE (TRUE: Maintenance)
Event_State	BACnetEventState	R	R	NORMAL fixed
Reliability	BACnetReliability	O	R	NO_FAULT_DETECTED: Normal communication UNRELIABLE_OTHER: Communication malfunction
Out_Of_Service	BOOLEAN	R	R	FALSE FIXED
Scale	BACnetScale	R	R	IntegerScale = -1 (Accumulated value = Present_Value × 10 ⁻¹)
Units	BACnetEngineeringUnits	R	R	kilowatt-hours(19) (In case of accumulated gas: cubic-meters(80))
Prescale	BACnetPrescale	O	-	
Max_Pres_Value	Unsigned	R	R	999999
Value_Change_Time	BACnetDateTime	O2	-	
Value_Before_Change	Unsigned	O2, 3	-	
Value_Set	Unsigned	O2, 3	-	
Logging_Record	BACnetAccumulatorRecord	O	-	
Logging_Object	BACnetObjectIdentifier	O	-	
Pulse_Rate	Unsigned	O1.4	-	
High_Limit	Unsigned	O4	-	
Low_Limit	Unsigned	O4	-	
Limit_Monitoring_Interval	Unsigned	O4	-	
Notification_Class	Unsigned	O4	-	
Time_Delay	Unsigned	O4	-	
Limit_Enable	BACnetLimitEnable	O4	-	
Event_Enable	BACnetEventTransitionBits	O4	-	
Acked_Transitions	BACnetEventTransitionBits	O4	-	
Notify_Type	BACnetNotifyType	O4	-	
Event_Time_Stamps	BACnetARRAY[3] of BACnetTimeStamp	O4	-	
Profile_Name	CharacterString	O	-	

CB07A004G

8.2 Analog Input Object Type

(1) Analog Input: Room temperature (measured suction temperature)

Property Identifier	Property Datatype	BACnet®	MS III	Note
Object_Identifier	BACnetObjectIdentifier	R	R	
Object_Name	CharacterString	R	R	
Object_Type	BACnetObjectType	R	R	ANALOG_INPUT
Present_Value	REAL	R1	R	
Description	CharacterString	O	-	
Device_Type	CharacterString	O	-	
Status_Flags	BACnetStatusFlags	R	R	IN_ALARM (TRUE: Upper/lower limit malfunction occurring) FAULT (TRUE: Communication malfunction or sensor malfunction) OVERRIDDEN (always FALSE) OUT_OF_SERVICE (always FALSE)
Event_State	BACnetEventState	R	R	NORMAL: Normal FAULT: Communication malfunction/sensor malfunction LOW_LIMIT: Lower limit malfunction occurring HIGH_LIMIT: Upper limit malfunction occurring
Reliability	BACnetReliability	O	R	NO_FAULT_DETECTED: Normal communication NO_SENSOR: sensor malfunction UNRELIABLE_OTHER: Communication malfunction
Out_Of_Service	BOOLEAN	R	R	Always FALSE
Update_Interval	Unsigned	O	-	
Units	BACnetEngineeringUnits	R	R	°C:degree-Celsius(62)/ °F:degree-Fahrenheit(64)
Min_Pres_Value	REAL	O	-	
Max_Pres_Value	REAL	O	-	
Resolution	REAL	O	-	
COV_Increment	REAL	O2	R	1.0 fixed
Time_Delay	Unsigned	O3	(R)	0 fixed
Notification_Class	Unsigned	O3	(R)	3 fixed
High_Limit	REAL	O3	(W)	Default: °C:+80.0 °F: +180.0
Low_Limit	REAL	O3	(W)	Default: °C:-80.0 °F: -120.0
Deadband	REAL	O3	(W)	Default: °C:+5.0 °F: +10.0
Limit_Enable	BACnetLimitEnable	O3	(W)	Default is all FALSE.
Event_Enable	BACnetEventTransitionBits	O3	(R)	B'101' fixed
Acked_Transitions	BACnetEventTransitionBits	O3	(R)	All TRUE fixed
Notify_Type	BACnetNotifyType	O3	(R)	ALARM fixed
Event_Time_Stamps	BACnetARRAY[3] of BACnetTimeStamp	O3	(R)	Reset by power off At start-up No event occurred: Time undefined Event occurring: Time of detection
Profile_Name	CharacterString	O	-	

CB07A004G

(2) Analog Input: Air direction (status)

Property Identifier	Property Datatype	BACnet®	MS III	Note
Object_Identifier	BACnetObjectIdentifier	R	R	
Object_Name	CharacterString	R	R	
Object_Type	BACnetObjectType	R	R	ANALOG_INPUT
Present_Value	REAL	R1	R	
Description	CharacterString	O	-	
Device_Type	CharacterString	O	-	
Status_Flags	BACnetStatusFlags	R	R	IN_ALARM (always FALSE) FAULT (TRUE: Communication malfunction) OVERRIDDEN (always FALSE) OUT_OF_SERVICE (always FALSE)
Event_State	BACnetEventState	R	R	NORMAL fixed
Reliability	BACnetReliability	O	R	NO_FAULT_DETECTED: Normal communication UNRELIABLE_OTHER: Communication malfunction
Out_Of_Service	BOOLEAN	R	R	Always FALSE
Update_Interval	Unsigned	O	-	
Units	BACnetEngineeringUnits	R	R	
Min_Pres_Value	REAL	O	-	
Max_Pres_Value	REAL	O	-	
Resolution	REAL	O	-	
COV_Increment	REAL	O2	R	1.0 fixed
Time_Delay	Unsigned	O3	-	
Notification_Class	Unsigned	O3	-	
High_Limit	REAL	O3	-	
Low_Limit	REAL	O3	-	
Deadband	REAL	O3	-	
Limit_Enable	BACnetLimitEnable	O3	-	
Event_Enable	BACnetEventTransitionBits	O3	-	
Acked_Transitions	BACnetEventTransitionBits	O3	-	
Notify_Type	BACnetNotifyType	O3	-	
Event_Time_Stamps	BACnetARRAY[3] of BACnetTimeStamp	O3	-	
Profile_Name	CharacterString	O	-	

CB07A004G

8.3 Analog Value Object Type

Property Identifier	Property Datatype	BACnet®	MSIII	Note
Object_Identifier	BACneObjectIdentifier	R	R	
Object_Name	CharacterString	R	R	
Object_Type	BACnetObjectType	R	R	ANALOG_VALUE
Present_Value	REAL	W	W	
Description	CharacterString	O	-	
Status_Flags	BACnetStatusFlags	R	R	IN_ALARM (always FALSE) FAULT (TRUE: Communication malfunction) OVERRIDDEN (always FALSE) OUT_OF_SERVICE (always FALSE)
Event_State	BACnetEventState	R	R	NORMAL fixed
Reliability	BACnetReliability	O	R	NO_FAULT_DETECTED: Normal communication UNRELIABLE_OTHER: Communication malfunction
Out_Of_Service	Boolean	R	R	Always FALSE
Units	BACnetEngineeringUnits	R	R	(Note) Set room temperature only. °C:degree-Celsius(62)/ °F:degree-Fahrenheit(64)
PriorityArray	BACnetPriorityArray	O1	R	
RelinquishDefault	REAL	O1	R	(Note) Set room temperature only. °C:25 °F:75
COV_Increment	REAL	O2	R	1.0 fixed
Time_Delay	Unsigned	O2	-	
Notification_Class	Unsigned	O3	-	
High_Limit	REAL	O3	-	
Low_Limit	REAL	O3	-	
Deadband	REAL	O3	-	
Limit_Enable	BACnetLimitEnable	O3	-	
Event_Enable	BACnetEventTransitionBits	O3	-	
Acked_Transitions	BACnetEventTransitionBits	O3	-	
Notify_Type	BACnetNotifyType	O3	-	
Event_Time_Stamps	BACnetARRAY[3] of BACnetTimeStamp	O3	-	
Profile_Name	CharacterString	O	-	

CB07A004G

8.4 Binary Input Object Type (Supported Intrinsic Reporting)

Property Identifier	Property Datatype	BACnet®	MS III	Note
Object_Identifier	BACnetObjectIdentifier	R	R	
Object_Name	CharacterString	R	R	
Object_Type	BACnetObjectType	R	R	BINARY_INPUT
Present_Value	BACnetBinaryPV	R1	R	
Description	CharacterString	O	R*	Support Alarm object only. Represents malfunction code with 2 ASCII codes.
Device_Type	CharacterString	O	-	
Status_Flags	BACnetStatusFlags	R	R	IN_ALARM (TRUE: Malfunction occurring) FAULT (TRUE: Communication malfunction) (Exception: FALSE fixed for Communication status object) OVERRIDDEN (always FALSE) OUT_OF_SERVICE (always FALSE)
Event_State	BACnetEventState	R	R	NORMAL: Malfunction not occurred OFF_NORMAL: Malfunction occurring
Reliability	BACnetReliability	O	R	NO_FAULT_DETECTED: Normal communication UNRELIABLE_OTHER: Communication malfunction
Out_Of_Service	Boolean	R	R	Always FALSE
Polarity	BACnetPolarity	R	R	NORMAL fixed
Inactive_Text	CharacterString	O2	-	
Active_Text	CharacterString	O2	-	
Change_Of_State_Time	BACnetDateTime	O3	-	
Change_Of_State_Count	Unsigned	O3	-	
Time_Of_State_Count_Reset	BACnetDateTime	O3	-	
Elapsed_Active_Time	Unsigned32	O4	-	
Time_Of_Active_Time_Reset	BACnetDateTime	O4	-	
Time_Delay	Unsigned	O5	(R)	0 fixed
Notification_Class	Unsigned	O5	(R)	3 fixed
Alarm_Value	BACnetBinaryPV	O5	(R)	ACTIVE fixed
Event_Enable	BACnetEventTransitionBits	O5	(R)	B'101' fixed
Acked_Transitions	BACnetEventTransitionBits	O5	(R)	All TRUE fixed
Notify_Type	BACnetNotifyType	O5	(R)	ALARM fixed
Event_Time_Stamps	BACnetARRAY[3] of BACnetTimeStamp	O5	(R)	Reset by power off At start-up Event not occurred: Time undefined Event occurring: Time of detection
Profile_Name	CharacterString	O	-	

CB07A004G

8.5 Binary Input Object Type (Non-supported Intrinsic Reporting)

(1) Binary Input: Start/stop (status)

Property Identifier	Property Datatype	BACnet®	MS III	Note
Object_Identifier	BACnetObjectIdentifier	R	R	
Object_Name	CharacterString	R	R	
Object_Type	BACnetObjectType	R	R	BINARY_INPUT
Present_Value	BACnetBinaryPV	R1	R	
Description	CharacterString	O	-	
Device_Type	CharacterString	O	-	
Status_Flags	BACnetStatusFlags	R	R	IN_ALARM (always FALSE) FAULT (TRUE: Communication malfunction) OVERRIDDEN (always FALSE) OUT_OF_SERVICE (always FALSE)
Event_State	BACnetEventState	R	R	NORMAL fixed
Reliability	BACnetReliability	O	R	NO_FAULT_DETECTED: Normal communication UNRELIABLE_OTHER: Communication malfunction
Out_Of_Service	Boolean	R	R	Always FALSE
Polarity	BACnetPolarity	R	R	NORMAL fixed
Inactive_Text	CharacterString	O2	-	
Active_Text	CharacterString	O2	-	
Change_Of_State_Time	BACnetDateTime	O3	R	
Change_Of_State_Count	Unsigned	O3	W	0-4294967295 (X'FFFFFFFF')
Time_Of_State_Count_Reset	BACnetDateTime	O3	R	
Elapsed_Active_Time	Unsigned32	O4	W	0-4294967295 (X'FFFFFFFF')
Time_Of_Active_Time_Reset	BACnetDateTime	O5	R	
Time_Delay	Unsigned	O5	-	
Notification_Class	Unsigned	O5	-	
Alarm_Value	BACnetBinaryPV	O5	-	
Event_Enable	BACnetEventTransitionBits	O5	-	
Acked_Transitions	BACnetEventTransitionBits	O5	-	
Notify_Type	BACnetNotifyType	O5	-	
Event_Time_Stamps	BACnetARRAY[3] of BACnetTimeStamp	O5	-	
Profile_Name	CharacterString	O	-	

CB07A004G

(2) Binary Input: Other

Property Identifier	Property Datatype	BACnet®	MS III	Note
Object_Identifier	BACnetObjectIdentifier	R	R	
Object_Name	CharacterString	R	R	
Object_Type	BACnetObjectType	R	R	BINARY_INPUT
Present_Value	BACnetBinaryPV	R1	R	
Description	CharacterString	O	-	
Device_Type	CharacterString	O	-	
Status_Flags	BACnetStatusFlags	R	R	IN_ALARM (always FALSE) FAULT (TRUE: Communication malfunction) OVERRIDDEN (always FALSE) OUT_OF_SERVICE (always FALSE)
Event_State	BACnetEventState	R	R	NORMAL fixed
Reliability	BACnetReliability	O	R	NO_FAULT_DETECTED: Normal communication UNRELIABLE_OTHER: Communication malfunction
Out_Of_Service	Boolean	R	R	Always FALSE
Polarity	BACnetPolarity	R	R	NORMAL fixed
Inactive_Text	CharacterString	O2	-	
Active_Text	CharacterString	O2	-	
Change_Of_State_Time	BACnetDateTime	O3	-	
Change_Of_State_Count	Unsigned	O3	-	
Time_Of_State_Count_Reset	BACnetDateTime	O3	-	
Elapsed_Active_Time	Unsigned32	O4	-	
Time_Of_Active_Time_Reset	BACnetDateTime	O5	-	
Time_Delay	Unsigned	O5	-	
Notification_Class	Unsigned	O5	-	
Alarm_Value	BACnetBinaryPV	O5	-	
Event_Enable	BACnetEventTransitionBits	O5	-	
Acked_Transitions	BACnetEventTransitionBits	O5	-	
Notify_Type	BACnetNotifyType	O5	-	
Event_Time_Stamps	BACnetARRAY[3] of BACnetTimeStamp	O5	-	
Profile_Name	CharacterString	O	-	

CB07A004G

8.6 Binary Output Object Type

Property Identifier	Property Datatype	BACnet®	MS III	Note
Object_Identifier	BACnetObjectIdentifier	R	R	
Object_Name	CharacterString	R	R	
Object_Type	BACnetObjectType	R	R	BINARY_OUTPUT
Present_Value	BACnetBinaryPV	R	W	
Description	CharacterString	O	-	
Device_Type	CharacterString	O	-	
Status_Flags	BACnetStatusFlags	R	R	IN_ALARM (always FALSE) FAULT (TRUE: Communication malfunction) OVERRIDDEN (always FALSE) OUT_OF_SERVICE (always FALSE)
Event_State	BACnetEventState	R	R	NORMAL fixed
Reliability	BACnetReliability	O	R	NO_FAULT_DETECTED: Normal communication UNRELIABLE_OTHER: Communication malfunction
Out_Of_Service	Boolean	R	R	Always FALSE
Polarity	BACnetPolarity	R	R	NORMAL fixed
Inactive_Text	CharacterString	O1	-	
Active_Text	CharacterString	O1	-	
Change_Of_State_Time	BACnetDateTime	O2	-	
Change_Of_State_Count	Unsigned	O2	-	
Time_Of_State_Count_Reset	BACnetDateTime	O2	-	
Elapsed_Active_Time	Unsigned32	O3	-	
Time_Of_Active_Time_Reset	BACnetDateTime	O3	-	
Minimum_Off_Time	Unsigned32	O	-	
Minimum_On_Time	Unsigned32	O	-	
Priority_Array	BACnetPriorityArray	R	R	
Relinquish_Default	BACnetBinaryPV	R	R	
Time_Delay	Unsigned	O4	-	
Notification_Class	Unsigned	O4	-	
Feedback_Value	BACnetBinaryPV	O4	-	
Event_Enable	BACnetEventTransitionBits	O4	-	
Acked_Transitions	BACnetEventTransitionBits	O4	-	
Notify_Type	BACnetNotifyType	O4	-	
Event_Time_Stamps	BACnetARRAY[3] of BACnetTimeStamp	O4	-	
Profile_Name	CharacterString	O	-	

CB07A004G

8.7 Binary Value Object Type

(1) Binary Value: Filter sign reset

Property Identifier	Property Datatype	BACnet®	MS III	Note
Object_Identifier	BACnetObjectIdentifier	R	R	
Object_Name	CharacterString	R	R	
Object_Type	BACnetObjectType	R	R	BINARY_VALUE
Present_Value	BACnetBinaryPV	R1	W	
Description	CharacterString	O	-	
Status_Flags	BACnetStatusFlags	R	R	IN_ALARM (TRUE: Filter sign ON) FAULT (TRUE: Communication malfunction) OVERRIDDEN (always FALSE) OUT_OF_SERVICE (always FALSE)
Event_State	BACnetEventState	R	R	NORMAL other OFF_NORMAL: Filter sign ON
Reliability	BACnetReliability	O	R	NO_FAULT_DETECTED: Normal communication UNRELIABLE_OTHER: Communication malfunction
Out_Of_Service	Boolean	R	R	Always FALSE
Inactive_Text	CharacterString	O2	-	
Active_Text	CharacterString	O2	-	
Change_Of_State_Time	BACnetDateTime	O3	-	
Change_Of_State_Count	Unsigned	O3	-	
Time_Of_State_Count_Reset	BACnetDateTime	O3	-	
Elapsed_Active_Time	Unsigned32	O4	-	
Time_Of_Active_Time_Reset	BACnetDateTime	O4	-	
Minimum_Off_Time	Unsigned32	O	-	
Minimum_On_Time	Unsigned32	O	-	
Priority_Array	BACnetPriorityArray	R5	R	
Relinquish_Default	BACnetBinaryPV	R5	R	
Time_Delay	Unsigned	O6	(R)	0 fixed
Notification_Class	Unsigned	O6	(R)	3 fixed
Alarm_Value	BACnetBinaryPV	O6	(R)	ACTIVE fixed
Event_Enable	BACnetEventTransitionBits	O6	(R)	B'101' fixed
Acked_Transitions	BACnetEventTransitionBits	O6	(R)	All TRUE fixed
Notify_Type	BACnetNotifyType	O6	(R)	ALARM fixed
Event_Time_Stamps	BACnetARRAY[3] of BACnetTimeStamp	O6	(R)	Reset by power off At start-up Event not occurred: Time undefined Event occurring: Time of detection
Profile_Name	CharacterString	O	-	

CB07A004G

(2) Binary Value: Other

Property Identifier	Property Datatype	BACnet®	MS III	Note
Object_Identifier	BACnetObjectIdentifier	R	R	
Object_Name	CharacterString	R	R	
Object_Type	BACnetObjectType	R	R	BINARY_VALUE
Present_Value	BACnetBinaryPV	R1	W	
Description	CharacterString	O	-	
Status_Flags	BACnetStatusFlags	R	R	IN_ALARM (always FALSE) FAULT (TRUE: Communication malfunction) OVERRIDDEN (always FALSE) OUT_OF_SERVICE (always FALSE)
Event_State	BACnetEventState	R	R	NORMAL fixed
Reliability	BACnetReliability	O	R	NO_FAULT_DETECTED: Normal communication UNRELIABLE_OTHER: Communication malfunction
Out_Of_Service	Boolean	R	R	Always FALSE
Inactive_Text	CharacterString	O2	-	
Active_Text	CharacterString	O2	-	
Change_Of_State_Time	BACnetDateTime	O3	-	
Change_Of_State_Count	Unsigned	O3	-	
Time_Of_State_Count_Reset	BACnetDateTime	O3	-	
Elapsed_Active_Time	Unsigned32	O4	-	
Time_Of_Active_Time_Reset	BACnetDateTime	O4	-	
Minimum_Off_Time	Unsigned32	O	-	
Minimum_On_Time	Unsigned32	O	-	
Priority_Array	BACnetPriorityArray	R5 O	R	
Relinquish_Default	BACnetBinaryPV	R5 O	R	
Time_Delay	Unsigned	O6	-	
Notification_Class	Unsigned	O6	-	
Alarm_Value	BACnetBinaryPV	O6	-	
Event_Enable	BACnetEventTransitionBits	O6	-	
Acked_Transitions	BACnetEventTransitionBits	O6	-	
Notify_Type	BACnetNotifyType	O6	-	
Event_Time_Stamps	BACnetARRAY[3] of BACnetTimeStamp	O6	-	
Profile_Name	CharacterString	O	-	

CB07A004G

8.8 Device Object Type

Property Identifier	Property Datatype	BACnet®	MS III	Note
Object_Identifier	BACnetObjectIdentifier	R	R	Can be set with Trial Operation tool
Object_Name	CharacterString	R	R	
Object_Type	BACnetObjectType	R	R	DEVICE
System_Status	BACnetDeviceStatus	R	R	D3 initializing: DOWNLOAD_IN_PROGRESS Normal: OPERATIONAL
Vendor_Name	CharacterString	R	R	DAIKIN Industries LTD
Vendor_Identifier	Unsigned16	R	R	53(=DAIKIN) fixed
Model_Name	CharacterString	R	R	"D-BACS Interface for use in BACnet®" fixed
Firmware_Revision	CharacterString	R	R	3000
Application_Software_Version	CharacterString	R	R	3000
Location	CharacterString	O	-	
Description	CharacterString	O	-	
Protocol_Version	Unsigned	R	R	1 fixed
Protocol_Revision	Unsigned	R	R	4
Protocol_Conformance_Class	Unsigned(1...6)	-	R	3 fixed
Protocol_Services_Supported	BACnetServiceSupported	R	R	SubCOV, RP, RPM, WP, WPM, I-Am, I-Have, TimeSync, Who-Is, Who-Has, UTCTimeSync (DeviceCommunicationControl *Ver 6.20 or later) (AddList, RemoveList * When event notification is supported)
Protocol_Object_Types_Supported	BACnetObjectTypesSupported	R	R	AI, AO, AV, BI, BO, BV, MI, MO, NotificationClass
Object_List	BACnetARRAY[N] of BACnetObjectIdentifier	R	R	
Max_APDU_Length_Accepted	Unsigned	R	R	BACnetIP: 1024
Segmentation_Supported	BACnetSegmentation	R	R	SEGMENTED_BOTH
Max_Segments_Accepted	Unsigned	O1	R	100 fixed
VT_Class_Supported	List of BACnetVTClass	O1	-	
Active_VT_Sessions	List of BACnetVTSession	O2	-	
Local_Time	Time	O3, 4	R	
Local_Date	Date	O3, 4	R	
UTC_Offset	Signed	O4	R	Can be set with Trial Operation tool Default: -540
Daylight_Saving_Status	Boolean	O4	R	FALSE fixed
APDU_Segment_Timeout	Unsigned	O1	R	Can be set with Trial Operation tool within the range form 1000 to 10000 Default: 2000 (msec)
APDU_Timeout	Unsigned	R	R	Can be set with Trial Operation tool within the range form 1000 to 120000 Default: 3000 (msec)
Number_Of_APDU_Retries	Unsigned	R	R	Can be set with Trial Operation tool within the range from 0 to 7 Default: 3 (times)
List_Of_Session_Keys	List of BACnetSessionKey	O	-	
Time_Synchronization_Recipients	List of BACnetRecipient	O5	-	
Max_Master	Unsigned(1...127)	O6	-	
Max_Info_Frames	Unsigned	O6	-	
Device_Adress_Binding	List of BACnetAddressBinding	R	R	
Database_Revision	Unsigned	R	R	
Configuration_Files	BACnetARRAY[N] of BACnetObjectIdentifier	O7	-	
Last_Restore_Time	BACnetDateTime	O7	-	
Backup_Failure_Timeout	Unsigned16	O8	-	
Active_COV_Subscriptions	List of BACnetCOVSubscription	O9	R	Supported by Ver 6.20 or later
Profile_Name	CharacterString	O	-	

CB07A004G

8.9 Multi-state Input Object Type

Property Identifier	Property Datatype	BACnet®	MS III	Note
Object_Identifier	BACnetObjectIdentifier	R	R	
Object_Name	CharacterString	R	R	
Object_Type	BACnetObjectType	R	R	MULTI-STATE_INPUT
Present_Value	Unsigned	R1	R	
Description	CharacterString	O	R*	Support malfunction code only. Represents failure code with 2 ASCII codes.
Device_Type	CharacterString	O	-	
Status_Flags	BACnetStatusFlags	R	R	IN_ALARM (always FALSE) FAULT (TRUE: Communication malfunction) OVERRIDDEN (always FALSE) OUT_OF_SERVICE (always FALSE)
Event_State	BACnetEventState	R	R	NORMAL fixed
Reliability	BACnetReliability	O2	R	NO_FAULT_DETECTED: Normal communication UNRELIABLE_OTHER: Communication malfunction
Out_Of_Service	Boolean	R	R	
Number_Of_States	Unsigned	R	R	
State_Text	BACnetARRAY[N] of CharacterString	O	-	
Time_Delay	Unsigned	O3	-	
Notification_Class	Unsigned	O3	-	
Alarm_Values	List of Unsigned	O3	-	
Fault_Values	List of Unsigned	O3	-	
Event_Enable	BACnetEventTransitionBits	O3	-	
Acked_Transitions	BACnetEventTransitionBits	O3	-	
Notify_Type	BACnetNotifyType	O3	-	
Event_Time_Stamps	BACnetARRAY[3] of BACnetTimeStamp	O3	-	
Profile_Name	CharacterString	O	-	

CB07A004G

8.10 Multi-state Output Object Type

Property Identifier	Property Datatype	BACnet®	MS III	Note
Object_Identifier	BACnetObjectIdentifier	R	R	
Object_Name	CharacterString	R	R	
Object_Type	BACnetObjectType	R	R	MULTI-STATE_OUTPUT
Present_Value	Unsigned	W	W	
Description	CharacterString	O	-	
Device_Type	CharacterString	O	-	
Status_Flags	BACnetStatusFlags	R	R	IN_ALARM (always FALSE) FAULT (TRUE: Communication malfunction) OVERRIDDEN (always FALSE) OUT_OF_SERVICE (always FALSE)
Event_State	BACnetEventState	R	R	NORMAL fixed
Reliability	BACnetReliability	O	R	NO_FAULT_DETECTED: Normal communication UNRELIABLE_OTHER: Communication malfunction
Out_Of_Service	Boolean	R	R	
Number_Of_States	Unsigned	R	R	
State_Text	BACnetARRAY[N] of CharacterString	O	-	
Priority_Array	BACnetPriorityArray	R	R	
Relinquish_Default	Unsigned	R	R	
Time_Delay	Unsigned	O1	-	
Notification_Class	Unsigned	O1	-	
Feedback_Value	Unsigned	O1	-	
Event_Enable	BACnetEventTransitionBits	O1	-	
Acked_Transitions	BACnetEventTransitionBits	O1	-	
Notify_Type	BACnetNotifyType	O1	-	
Event_Time_Stamps	BACnetARRAY[3] of BACnetTimeStamp	O1	-	
Profile_Name	CharacterString	O	-	

CB07A004G

9. Report Function

9.1 COV Notification

The COV notification with subscription (DS-COV-B) and no subscription (DS-COVU B) are supported.

9.1.1. COV notification with subscription (subscribed COV)

COV subscription request is received by the SubscribeCOV service.

- (1) Setting COV generation with/without confirmation
Supported as defined in the BACnet® specifications.
- (2) Validity period for notification
Supported as defined in the BACnet® specifications.
When executing COV notification at status change, the system calculates the difference between the current time and registered time, then it will delete the COV notification if the difference is larger than the validity period. Therefore, if the clock is changed, the actual validity period may differ from the defined period.
- (3) Memorization at power off
Not supported.
Since the subscribed information is not saved, it will be deleted at power off.
The BACnet® specifications do not require memorization at power off.
- (4) Notification recipient information
The notification recipient information is not visible from the BACnet®. The BACnet® specifications do not require network visibility.
- (5) Number of notification recipients
5 clients per object.
Specifying more than 5 recipients will return ErrorPDU of Error Class = SERVICES,
Error Code = COV_SUBSCRIPTION_FAILED.

COV notification is supported for all the objects (except for accumulated power) for the air conditioner.

9.1.2. Unsubscribed COV notification (Unsolicited COV)

Unsubscribed COV (equivalent to BIBB's DS-COVU B) is supported by configuring the Daikin Trial Operation tool in advance.

COV notification is supported for all the objects (except for accumulated power) for the air conditioner.

CB07A004G

9.2 Event Notification

Event notification only supports the intrinsic notification. Since this is an optional function, it must be enabled using the Trial Operation tool. (It is disabled by default.)

9.2.1 Event notification recipient information

Only one Notification Class object is generated and referenced from all the objects supporting intrinsic notification. A notification recipient registered with this Notification Class object is notified of events from all the objects.

- (1) Instance number of notification class
Fixed to 3.
- (2) Priority
Fixed to 255.
- (3) Ack_Required
Fixed to FALSE (not to expect the AcknowledgeAlarm service for events).

9.2.2 Event notification recipient registration

The notification recipient is registered in the Recipient_List property of the Notification Class object using the AddListElement service. The notification recipient information is registered as BACnetDestination, which consists of the following information:

- (1) Effective date
In accordance with the BACnet® specifications. Specify the day of the week and whether or not to notify events.
- (2) Effective time
In accordance with the BACnet® specifications. Specify the time zone and whether or not to notify events.
- (3) Process ID
In accordance with the BACnet® specifications. Use the process ID registered with event notification.
- (4) Notification recipient address information
In accordance with the BACnet® specifications. The device object ID or BACnetAddress can be specified. When specifying the device object ID, the correspondence between the device object ID and BACnetAddress must be made clear (with the I-Am service, for example) before the event notification. The correspondence information is stored in the device object's Device_Address_Binding property. At start-up, the Who-Is service is transmitted and I-Am is received. If this information is missing for some reason, the event notification will be cancelled. If no BACnet® packet is received from the other party for 10 minutes, that BACnet® device is considered to be disconnected from the network. If the I-Am service is not received after that, the device object ID becomes undefined, and the notification recipient with that device object ID specified will not be notified of the event.
- (5) Confirmation
In accordance with the BACnet® specifications. Event notification can be registered with or without confirmation.
- (6) Transitions
Although the value is retained, processing is ignored.
- (7) Maximum number of notification recipients registered
10 clients.
Specifying more than 10 recipients will return ErrorPDU of ErrorClass = RESOURCES, Error Code = NO_SPACE_TO_WRITEPROPERTY (for WriteProperty, WritePropertyMultiple) or NO_SPACE_TO_ADD_LIST_ELEMENT (for AddListElement)

9.2.3 Event notification recipient deletion

Notification recipient can be deleted from the Notification Class object with the RemoveListElement service. Process ID and corresponding notification recipient address are required to delete a recipient. A recipient with the same notification recipient address but different process ID is not deleted.

CB07A004G

9.2.4. Event notification recipient re-registration

If an event with the same process ID and notification recipient address as an existing event is re-registered, the existing information is overwritten. Therefore, effective date/time or confirmation settings will be updated.

9.2.5. Event notification recipient memorization

Registered event notification recipients are saved in the nonvolatile memory and the event notification information is initialized with the saved recipient information at start up. Event notification recipient information is updated in 5 seconds after addition or deletion.

9.2.6. Event confirmation

The event confirmation defined by the BACnet[®] specifications is not supported, as mentioned below.

- (1) The AcknowledgeAlarm service is not supported.
- (2) The Notification Class object's Ack_Required is all fixed to FALSE.
- (3) The Event sending object's Ack_Transition is all fixed to TRUE.

To retain events occurring when a notification recipient is offline or disconnected from the network, the time stamp for event occurrence is maintained, but not retained at power off. If an event has already occurred at power up, the time when the event has been detected is used for the time stamp.

CB07A004G

10. Error Response in BACnet® Communication

If a request from the BACnet® client cannot be handled, one of the ErrorPDUs listed below will be returned.

Error PDU

Error PDU	Error Class	Error Code
Read for the list of object initializing on the D3 network.	DEVICE (0)	CONFIGURATION_IN_PROGRESS (2)
Access request for unimplemented object.	OBJECT (1)	UNKNOWN_OBJECT (31)
Access request for unimplemented property.	PROPERTY (2)	UNKNOWN_PROPERTY (32)
Write request for a write-inhibited property.	PROPERTY (2)	WRITE_ACCESS_DENIED (40)
Write request with wrong type for a property.	PROPERTY (2)	NVALID_DATATYPE (9)
Access request with out-of-range index specification for an array-type property.	PROPERTY (2)	INVALID_ARRAY_INDEX (42)
Access request with index specification for non-array-type property.	PROPERTY (2)	PROPERTY_IS_NOT_AN_ARRAY(50)
Write request with out-of-range value.	PROPERTY (2)	VALUE_OUT_OF_RANGE (37)
COV registration for an object not supporting COV notification.	SERVICES (5)	OTHER (0)
5th COV recipient registration request	SERVICES (5)	COV_SUBSCRIPTION_FAILED (43)
11th event registration request (for AddListElement)	RESOURCES (3)	NO_SPACE_TO_ADD_LIST_ELEMENT (19)
11th event registration request (for WriteProperty(Multiple))	RESOURCES (3)	NO_SPACE_TO_WRITE_PROPERTY(20)
Delete request for an element not in the list.	SERVICES (5)	OTHER (0)
Execution request of the AddListElement/RemoveListElement service for non-list-type property.	SERVICES (5)	PROPERTY_IS_NOT_A_LIST (22)

Reject PDU

Reject PDU	Reject Reason
Property ID or value is missing for WritePropertyMultiple.	INCONSISTENT_PARAMETER (2)
Argument type is different for the service.	INVALID_PARAMETER_DATA_TYPE (3)
Error was detected in tag decoding.	INVALID_TAG (4)
Parameter is missing in service execution.	MISSING_REQUIRED_PARAMETER (5)
Arguments are too many for the service.	TOO_MANY_ARGUMENTS (7)
Execution of unsupported service with confirmation.	UNRECOGNIZED_SERVICE (9)

Abort PDU

Abort PDU	Abort Reason
- Process overflow due to too many requests. - Response message size exceeded the longest possible size (100 segments).	BUFFER_OVERFLOW (1)
Unexpected APDU has been received during segment processing and processing aborted.	INVALID_APDU_IN_THIS_STATE (2)
Respondent does not support segments in segment response.	SEGMENTATION_NOT_SUPPORTED (4)

CB07A004G

11. Detailed Description of Objects

11.1 Common to All Objects

For each air conditioner's communication status, objects related to the air condition are treated on the BACnet as follows:

- (1) Air conditioner communicating normally
Other BACnet devices can access to the air conditioner's objects.
- (2) Air conditioner not connected
Other BACnet devices cannot see the air conditioner's objects.
Therefore, ErrorPDU of ErrorClass = OBJECT, ErrorCode = UNKNOWN_PROPERTY will be returned in response to a received ReadProperty/WriteProperty service.
- (3) Air conditioner communicating abnormally
Although other BACnet devices can access to the air conditioner's objects, values immediately before communication malfunction occurrence will be returned in response to status read requests.
In this case, each object's Reliability property shows UNRELIABLE_OTHER. This property shows NO_FAULT_DETECTED during normal communication and the FAULT flag of the Status_Flags is set to TRUE.
Even when the device is in communication malfunction status, any command issued will be sent to the air conditioner line.

- (Note 1) The air conditioner saves the settings for the temperature, start/stop status, air-conditioning mode, air direction, and airflow rate in the nonvolatile memory each time they are changed, so that the settings will not be lost when a power cut occurs.
This nonvolatile memory has a write count limit and may cause a failure if it is written exceeding the limit count.
Therefore when the temperature, start/stop status, air-conditioning mode, air direction, and airflow rate of each indoor unit are automatically controlled from the central monitoring panel, be sure that the number of changes for each setting **should not exceed 7,000 times per year.**

CB07A004G

11.2 Start/Stop (Setting)

Member number: 1

Object name: StartStopCommand_XXX (XXX represents the air conditioner's group number.)

Object type: Binary output

Description: This object is used to start/stop the air conditioner.

Present_Value property:

ACTIVE: Start

INACTIVE: Stop

Notes:

- (1) Any command issued will be sent to the air conditioner without regard to the air conditioner status.
- (2) If the Present_Value property has not been set, it defaults to INACTIVE.
- (3) The Relinquish_Default property is fixed to INACTIVE.

11.3 Start/Stop (Status)

Member number: 2

Object name: StartStopStatus_XXX (XXX represents the air conditioner's group number.)

Object type: Binary input

Description: This object is used to monitor the air conditioner's start/stop status.

Present_Value property:

ACTIVE: Operating

INACTIVE: Stopped

Notes:

- (1) In case of an operation malfunction, the Present_Value property shows ACTIVE even if the air conditioner is actually stopped.
- (2) The IN_ALARM flag of the Status_Flags property of the start/stop (status) object of the malfunctioning air conditioner is not set to TRUE. To detect occurrence of a malfunction, always refer to the Alarm object value.
- (3) Accumulation function for the total start/stop counts and total operation time is provided (to support the following properties).
Change_Of_State_Time, Change_Of_State_Count, Time_Of_State_Count_Reset,
Elapsed_Active_Time, and Time_Of_Active_Time_Reset

CB07A004G

11.4 Alarm

Member number: 3

Object name: Alarm_XXX (XXX represents the air conditioner's group number.)

Object type: Binary input

Description: This object is used to monitor the air conditioner's normal/malfunction status.

Present_Value property:

ACTIVE: Malfunction

INACTIVE: Normal

Notes:

- (1) This object supports the Intrinsic Reporting function, and if events are registered, it will generate an appropriate event when the Present_Value property changes the value. (Since this is an optional function, it must be enabled using the Trial Operation tool.)
- (2) Detailed information is stored in the following properties:
 - Time_Delay property: Malfunction notification delay is fixed to 0 and this property cannot be written.
 - Notify_Type property: Event notification is fixed to ALARM.
 - Event_Time_Stamps property: Indicates the time of occurrence (To-OFFNORMAL)/recovery (To-NORMAL).
 - At start-up:
 - Event not occurred: Time is not undefined.
 - Event occurring: Event detection time is written at start-up.
 - When power is off, the time is determined at start-up.
- (3) Malfunction means that the air conditioner is stopped for some trouble, and does not include Alarm or Warning which may be caused by other reasons. However, whether Alarm is included in Malfunction can be selected with a test operation PC. By default, Alarm is included in Malfunction.
- (4) To stop the malfunction signal from a malfunctioning air conditioner, send the Stop command to that air conditioner. However, since the malfunction status persists, sending the Start command results in another malfunction.
- (5) The Description property represents a failure code defined by Daikin with two ASCII characters.

11.5 Malfunction Code

Member number: 4

Object name: MalfunctionCode_XXX (XXX represents the air conditioner's group number.)

Object type: Multistate Input

Description: This object is used to monitor the malfunction details of an air conditioner in malfunction status.

Present_Value property:

1 - 512 (mapped to a failure code)

Notes:

- (1) The Description property represents a failure code defined by Daikin with 2 ASCII characters.
- (2) Refer to the mapping table at the end of this specifications manual for the correspondence between the Present_Value property values and failure codes.

CB07A004G

11.6 Air-conditioning Mode (Setting)

Member number: 5

Object name: AirConModeCommand_XXX (XXX represents the air conditioner's group number.)

Object type: Multistate Output

Description: This object is used to set an air conditioner's air-conditioning mode.

Present_Value property:

- 1: Cooling mode
- 2: Heating mode
- 3: Ventilating mode
- 4: Auto mode
- 5: Dry mode

Notes:

- (1) If the Present_Value property has not been set, it defaults to "1: Cooling mode".
- (2) The Relinquish_Default property is fixed to "1: Cooling mode".
- (3) A command sent to this object of an air conditioner which cannot select the air-conditioning mode is ignored. The control/monitor system must not use this object for an air conditioner which cannot select the air-conditioning mode.
- (4) When "4: Auto mode" is selected, the air-conditioning mode (status) object shows the actual mode in which the air conditioner is operating, but not "Auto".
- (5) When "5: Dry mode" is selected, any indoor unit with no cooling/heating selection right for the same refrigerant system will not change to the "Dry" mode except in the cooling mode.

11.7 Air-conditioning Mode (Status)

Member number: 6

Object name: AirConModeStatus_XXX (XXX represents the air conditioner's group number.)

Object type: Multistate Input

Description: This object is used to monitor an air conditioner's air-conditioning mode.

Present_Value property:

- 1: Cooling mode
- 2: Heating mode
- 3: Fan mode
- 4: (Not used)
- 5: Dry mode

Notes:

- (1) If the air-conditioning mode (setting) object is set to "Auto", the current operation mode (Cooling, Heating, Fan or Dry) is returned with this property.

CB07A004G

11.8 Airflow Rate Level (Setting)

Member number: 7

Object name: AirFlowRateCommand_XXX (XXX represents the air conditioner's group number.)

Object type: Multistate Output

Description: This object is used to set an air conditioner's airflow rate level.

Present_Value property:

- 1: "Low"
- 2: "High"
- 3: "Middle"
- 4: "Auto"

Notes:

- (1) Since the air conditioner has two values for the airflow rate (for cooling and heating), this object sets the airflow rate level for the current air-conditioning mode.
- (2) If "Middle" is set for an air conditioner with 2-level airflow rate, it operates with the "High" setting.
- (3) If "Auto" is set for an air conditioner without automatic airflow rate, it returns an ErrorPDU with `ErrorClass = PROPERTY` and `ErrorCode = OTHER`.

11.9 Airflow Rate Level (Status)

Member number: 8

Object name: AirFlowRateStatus_XXX (XXX represents the air conditioner's group number.)

Object type: Multistate Input

Description: This object is used to monitor the air conditioner's airflow rate level.

Present_Value property:

- 1: "Low"
- 2: "High"
- 3: "Middle"
- 4: "Auto"

Notes:

- (1) The air conditioner has 2 values for the airflow rate (for cooling and heating).
- (2) Since the airflow rate level notification returns the airflow rate currently set with the air conditioner, without regard to the start/stop status.

CB07A004G

11.10 Measured Room Temperature

Member number: 9

Object name: RoomTemp_XXX (XXX represents the air conditioner's group number.)

Object type: Analog Input

Description: This object is used to monitor the room temperature detected by the air conditioner. The room temperature detected by the air conditioner slightly varies according to the location of the temperature sensor.

Present_Value property:

The room temperature detected by the air conditioner.

Notes:

- (1) The value is in degrees centigrade or degrees fahrenheit.
Interface for use in BACnet® outputs the measured temperature notified from the air conditioner as it is.
- (2) If it is subscribed with COV, the COV_Increment property is fixed to 1.0 and it cannot be written.
When a temperature change larger than 1.0 degree(°C/°F) is detected, COV is reported.
Then, when the Present_Value property value further changes for 1.0 degree(°C/°F) or more, another COV will be reported.
- (3) This object supports the Intrinsic Reporting function, and if events are registered, it will generate an appropriate event when the temperature goes over the specified upper limit or under the lower limit. The event is generated as defined in the BACnet specifications. (Since this is an optional function, it must be enabled using the Trial Operation tool.)
- (4) The upper/lower limit values are stored in the following properties:
High_Limi property: Upper limit value. This property can be written with a new value, which is stored in this property in 5 seconds after the write operation.
Low_Limi property: Lower limit value. This property can be written with a new value, which is stored in this property in 5 seconds after the write operation.
Deadband property: Insensitive temperature zone. This property can be written with a new value, which is stored in this property in 5 seconds after the write operation.

Default values shown in the following table.

property	High_Limit property	Low_Limit property	Deadband property
Representation			
Celsius	+80.0°C	-80.0°C	+5.0°C
Fahrenheit	+180.0°F	-120.0°F	+10.0°F

Time_Delay property: Upper/lower limit malfunction notification delay is fixed to 0 and this property cannot be written.

Notify_Type property: Event notification is fixed to ALARM.

Event_Time_Stamps property: Indicates the time of occurrence (To-OFFNORMAL)/recovery (To-NORMAL).

At start-up:

Event not occurred: Time is not undefined.

Event occurring: Event detection time is written at start-up.

When power is off, the time is determined at start-up.

- (5) If the air conditioner does not have the room temperature sensor, the Present_Value property shows 0.0.
- (6) If the room temperature sensor is removed, the Reliability property changes to NO_SENSOR and the FAULT flag of the Status_Flags property changes to TRUE. The Present_Value property retains the last value.
- (7) The room temperature is measured with the suction air. Since the indoor unit fan stops when the thermostat is disabled or the air conditioner is stopped, or in a special operation such as defrosting, temperature measurement may be affected by the heat exchanger, and may detect and transmit a different temperature from the actual room temperature.
For this reason, this value should be considered as a reference for the room temperature.
If the building management system manufacturer uses this value for system control (e.g., switching the air-conditioning mode or preset temperature), the manufacturer must take on the whole responsibility.
- (8) The units property is fixed to “degrees-Celsius(62)/degrees-Fahrenheit(64)”.

CB07A004G

11.11 Set Room Temperature

Member number: 10

Object name: TempAdjust_XXX (XXX represents the air conditioner's group number.)

Object type: Analog Value

Description: This object is used to set the air conditioner's temperature.

Present_Value property:

Air conditioner's set temperature

Notes:

- (1) The value is in degrees centigrade or degrees fahrenheit.
Its range depends on the types of the indoor and outdoor units.
For the VRV, for example, the value ranges from approximately 20°C to 35°C for cooling and approximately 15°C to 30°C for heating.
- (2) If it is subscribed with COV, the COV_Increment property is fixed to 1.0 and it cannot be written.
When a temperature change larger than 1 degree(°C/°F) is detected, COV is reported.
Then, when the Present_Value property value further changes for 1 degree(°C/°F) or more, another COV will be reported.
- (3) The available upper and lower limit values depend on the type of the air conditioner and the current air-conditioning mode. A value outside the available range can be specified, however, the air conditioner automatically rounds the specified value to the nearest limit value.
- (4) The air conditioner has 2 set temperatures (for cooling and heating). When changing the air-conditioning mode and set temperature, first set the air-conditioning mode, then change the set temperature after the air-conditioning mode has been settled. For example, if you want to change from 28°C (82°F) for cooling to 20°C (68°F) for heating, changing the set temperature first to 20°C will change the value for cooling, and when you change the air-conditioning mode to heating, the air conditioner will operate at the set temperature for heating stored in the nonvolatile memory.
- (5) The units property is fixed to “degrees-Celsius(62)/degrees-Fahrenheit(64)”.
- (6) Relinquish_Default property is fixed to “25(in the case of Celsius)/75(in the case of Fahrenheit)”.
- (7) When the set temperature in Fahrenheit is commanded from the central monitoring panel, the value must be given in "integer increments" as the air conditioner is controlled in integer increments for Fahrenheit.
- (8) When the set temperature in Fahrenheit is commanded from the central monitoring panel in first decimal place increments, the commanded value to the air conditioner may not match the return value from the air conditioner. Therefore when the set temperature is automatically controlled from the central monitoring panel, do not keep commanding the set temperature until the commanded value matches the return value.

When the set temperature in Fahrenheit is commanded from the central monitoring panel in first decimal place increments, the displayed value on the central monitoring panel may differ from the displayed value on our controller products and remote controllers.

CB07A004G

11.12 Filter Sign Signal

Member number: 11

Object name: FilterSign_XXX (XXX represents the air conditioner's group number.)

Object type: Binary input

Description: This object is used to monitor the air conditioner's filter sign status.

Present_Value property:

ACTIVE: Filter sign signal is ON.

(Signal for any of the normal filter, L/L filter, super L/L filter, or dust element is ON.)

INACTIVE: Filter sign signal is OFF.

Notes:

- (1) This object supports the Intrinsic Reporting function, and if events are registered, it will generate an appropriate event when the Present_Value property changes the value. (Since this is an optional function, it must be enabled using the Trial Operation tool.)
- (2) Detailed information is stored in the following properties:
 - Time_Delay property: Malfunction notification delay is fixed to 0 and this property cannot be written.
 - Notify_Type property: Event notification is fixed to ALARM.
 - Event_Time_Stamps property: Indicates the time of occurrence (To-OFFNORMAL)/recovery (To-NORMAL).
 - At start-up:
 - Event not occurred: Time is not undefined.
 - Event occurring: Event detection time is written at start-up.
 - When power is off, the time is determined at start-up.

11.13 Filter Sign Signal Reset

Member number: 12

Object name: FilterSignReset_XXX (XXX represents the air conditioner's group number.)

Object type: Binary Value

Description: This object is used to reset the air conditioner's filter sign signal.

Present_Value property:

INACTIVE: Resets the filter sign signal

Notes:

- (1) When reading the Present_Value property, it is always the same value as the filter sign signal object.
- (2) The filter sign signal which is ON is reset only when INACTIVE is written to the Present_Value property. ACTIVE written to this property is ignored.
- (3) This object supports the Intrinsic Reporting function, and if events are registered, it will generate an appropriate event when the Present_Value property changes the value. (Since this is an optional function, it must be enabled using the Trial Operation tool.)
- (4) Detailed information is stored in the following properties:
 - Time_Delay property: Malfunction notification delay is fixed to 0 and this property cannot be written.
 - Notify_Type property: Event notification is fixed to ALARM.
 - Event_Time_Stamps property: Indicates the time of occurrence (To-OFFNORMAL)/recovery (To-NORMAL).
 - At start-up:
 - Event not occurred: Time is not undefined.
 - Event occurring: Event detection time is written at start-up.
 - When power is off, the time is determined at start-up.

CB07A004G

11.14 Remote Controller Enable/Disable (Start/Stop)

Member number: 13

Object name: RemoteControlStart_XXX (XXX represents the air conditioner's group number.)

Object type: Binary Value

Description: This object is used to enable or disable the remote controller to start/stop the air conditioner.

Present_Value property:

ACTIVE: Disable the remote controller to start/stop the air conditioner.

INACTIVE: Enable the remote controller to start/stop the air conditioner.

Note:

- (1) If a remote controller group is used, remote controller enable/disable monitor/control is not available for the controllers other than the master remote controller (i.e., child controllers). Although each of other air conditioners other than the one with the master remote controller has this object, do not use it for mapping on other BACnet® devices.

11.15 Remote Controller Enable/Disable (Air-conditioning Mode)

Member number: 14

Object name: RemoteControlAirConModeSet_XXX (XXX represents the air conditioner's group number.)

Object type: Binary Value

Description: This object is used to enable or disable the remote controller to change the air conditioner's air-conditioning mode.

Present_Value property:

ACTIVE: Disable the remote controller to change the air conditioner's air-conditioning mode.

INACTIVE: Enable the remote controller to change the air conditioner's air-conditioning mode.

Note:

- (1) If a remote controller group is used, remote controller enable/disable monitor/control is not available for the controllers other than the master remote controller (i.e., child controllers). Although each of other air conditioners other than the one with the master remote controller has this object, do not use it for mapping on other BACnet® devices.

11.16 Remote Controller Enable/Disable (Set Temperature)

Member number: 16

Object name: RemoteControlTempAdjust_XXX (XXX represents the air conditioner's group number.)

Object type: Binary Value

Description: This object is used to enable or disable the remote controller to set the air conditioner's temperature.

Present_Value property:

ACTIVE: Disable the remote controller to set the air conditioner's temperature.

INACTIVE: Enable the remote controller to set the air conditioner's temperature.

Note:

- (1) If a remote controller group is used, remote controller enable/disable monitor/control is not available for the controllers other than the master remote controller (i.e., child controllers). Although each of other air conditioners other than the one with the master remote controller has this object, do not use it for mapping on other BACnet® devices.

CB07A004G

11.17 Central Control (Lower Central Control Disable)

Member number: 17

Object name: CL_Rejection_XXX (XXX can be 000, 064, 128, or 192, corresponding to the port number.)

Object type: Binary Value

Description: This object is used to disable or enable control by the central control device connected to the specified port on the D3 network.

Present_Value property:

ACTIVE: Disable central control by lower device

INACTIVE: Enable central control by lower device

11.18 Accumulated Power

Member number: 19

Object name: ElecTotalPower_XXX (XXX represents the air conditioner number.)

Description: This object is used to instruct the air conditioner to perform the proportional power distribution trial operation, then calculates the power consumed by the air conditioner in the operation.

Object type: Accumulator

Present_Value property:

This property represents the accumulated power in 0.1 kWh. A value smaller than 0.1kWh is rounded up.

The effective number of digits is 6 (000000 - 999999), and the value returns to 000000 after 999999.

The accumulated power for an air conditioner which does not perform the proportional power distribution trial operation, or which is not the recipient of the operation is shown as "0".

Unit property: kilowatt-hours (19)

Scale property: 0.1

Notes:

- (1) The value is updated at every hour on the hour. Therefore, the last accumulated value can be read until the next every hour.
- (2) Initialization of the value (i.e., adjustment of meter value) is not supported.
- (3) Only the normal (non-storage) air conditioner is supported, and the storage air conditioner is not supported.

(Note)

In general, child remote controllers are not monitored by upper central control devices and therefore do not have air conditioner addresses. However, they are taken into account in the proportional power distribution operation and need the air conditioner addresses. In this system, all the monitor/control objects of a remote controller which has the air conditioner address are visible from the central control device and those objects which are not necessary for the remote controller's control/monitor are also accessible. Thus, when performing the proportional power distribution operation, do not map (to an upper central control device) any objects other than the accumulated power object for the child remote controller.

CB07A004G

11.19 Communication Status

Member number: 20

Object name: CommunicationStatus_XXX (XXX represents the air conditioner's group number.)

Object type: Binary input

Description: This object is used to monitor the air conditioner's D3 network communication status.

Present_Value property:

ACTIVE: Air conditioner is communicating abnormally.

INACTIVE: Air conditioner is communicating normally.

Notes:

- (1) This object supports the Intrinsic Reporting function, and if events are registered, it will generate an appropriate event when the Present_Value property changes the value. (Since this is an optional function, it must be enabled using the Trial Operation tool.)
- (2) Detailed information is stored in the following properties:
 - Time_Delay property: Malfunction notification delay is fixed to 0 and this property cannot be written.
 - Notify_Type property: Event notification is fixed to ALARM.
 - Event_Time_Stamps property: Indicates the time of occurrence (To-OFFNORMAL)/recovery (To-NORMAL).
 - At start-up:
 - Event not occurred: Time is not undefined.
 - Event occurring: Event detection time is written at start-up.
 - When power is off, the time is determined at start-up.
- (3) Even when the air conditioner's communication malfunction occurs, the Reliability property does not change to UNRELIABLE_OTHER and remains NO_FAULT_DETECTED. Therefore, the Fault flag of the Status_Flags property also remains FALSE.

11.20 Forced System Stop

Member number: 21

Object name: SystemForcedOff_XXX ((XXX can be 000, 064, 128, or 192, corresponding to the port number.)

Object type: Binary Value

Description: This object is used to stop all the air conditioners connected to the specified D3 network port and disable/enable remote controller for them.

Present_Value property:

ACTIVE: Enable forced system stop.

INACTIVE: Clear forced system stop.

Notes:

- (1) When the forced system stop is enabled, the Stop and Remote controller disable to start commands are sent to the air conditioner (the remote controller can be used to stop the air conditioner).
- (2) When the forced system stop is cleared, the remote controller setting returns to the remote controller enable/disable status before the forced stop command. The air conditioner remains stopped and does not automatically restart. The host must instruct the air conditioner to restart.
- (3) After the forced system stop, the air conditioner may not accept the forced system stop clear and restart commands until it confirms that all the other air conditioners have been stopped (due to delay).

CB07A004G

11.21 Air Direction (Setting)

Member number: 22

Object name: AirDirectionCommand_XXX (XXX represents the air conditioner's group number.)

Object type: Analog Value

Description: This object is used to change the air conditioner's air direction

Present_Value property:

0, 1, 2, 3, 4, or 7 can be specified.

0 - 3: Horizontal

4: Vertical

7: Swing

Notes:

- (1) Since the air conditioner has 2 air direction values (for cooling and heating), the air direction value may change when the air conditioner's air-conditioning mode is changed.
- (2) When reading the air direction status, the value set with the air conditioner is returned.

11.22 Air Direction (Status)

Member number: 23

Object name: AirDirectionStatus_XXX (XXX represents the air conditioner's group number.)

Object type: Analog Input

Description: This object is used to monitor the air conditioner's air direction setting.

Present_Value property:

The value can be 0, 1, 2, 3, 4, or 7.

0 - 3: Horizontal

4: Vertical

7: Swing

Notes:

- (1) The value returned is always the same as that of the airflow rate (setting) object's Present_Value.
- (2) Since the airflow rate notification object returns the airflow rate value set with the remote controller, it does not change to 0 even when the air conditioner is stopped.
- (3) Since the air conditioner has 2 air direction values (for cooling and heating), the air direction value may change when the air conditioner's air-conditioning mode is changed.

CB07A004G

11.23 Forced Thermostat Disable (Setting)

Member number: 24

Object name: ForcedThermoOFFCommand_XXX (XXX represents the air conditioner's group number.)

Object type: Binary output

Description: This object is used to forcibly instruct the air conditioner to operate with or without temperature control.

Present_Value property:

ACTIVE: Enable forced thermostat disable mode

INACTIVE: Disable forced thermostat disable mode

Notes:

- (1) Any command issued will be sent to the air conditioner without regard to the air conditioner status.
- (2) If the Present_Value property has not been set, it defaults to INACTIVE.
- (3) The Relinquish_Default property is fixed to INACTIVE.

11.24 Forced Thermostat Disable (Status)

Member number: 25

Object name: ForcedThermoOFFStatus_XXX (XXX represents the air conditioner's group number.)

Object type: Binary input

Description: This object is used to monitor whether or not the air conditioner is forced to operate with or without temperature control.

Present_Value property:

ACTIVE: Forced thermostat disable mode is enabled

INACTIVE: Forced thermostat disable mode is disabled

11.25 Energy Saving (Setting)

Member number: 26

Object name: EnergyEfficiencyCommand_XXX (XXX represents the air conditioner's group number.)

Object type: Binary output

Description: This object is used to instruct the air conditioner to operate at a temperature shifted by 2 degrees from the set temperature for saving energy.

Regardless of Celsius or Fahrenheit, the shift width value is "2 degrees (Celsius)",

Because this set temperature shift is controlled in the air conditioner.

In addition, the set temperature notified to the central monitoring panel don't change.

Present_Value property:

ACTIVE: Enable energy saving

INACTIVE: Disable energy saving

Notes:

- (1) Any command issued will be sent to the air conditioner without regard to the air conditioner status.
- (2) If the Present_Value property has not been set, it defaults to INACTIVE.
- (3) The Relinquish_Default property is fixed to INACTIVE.

11.26 Energy Saving (Status)

Member number: 27

Object name: EnergyEfficiencyCommand_XXX (XXX represents the air conditioner's group number.)

Object type: Binary input

Description: This object is used to monitor whether or not the air conditioner is operating at a temperature shifted by 2 degrees from the set temperature for saving energy.

Regardless of Celsius or Fahrenheit, the shift width value is "2 degrees (Celsius)".

Because this set temperature shift is controlled in the air conditioner.

In addition, the set temperature notified to the central monitoring panel don't change.

Present_Value property:

ACTIVE: Energy saving enabled

INACTIVE: Energy saving disabled

CB07A004G

11.27 Thermostat Status

Member number: 28

Object name: ThermoStatus_XXX (XXX represents the air conditioner's group number.)

Object type: Binary input

Description: This object is used to monitor whether or not the air conditioner is controlling temperature.

Present_Value property:

ACTIVE: air conditioner is controlling temperature (thermostat enable)

INACTIVE: air conditioner is not controlling temperature (thermostat disable)

11.28 Compressor Status

Member number: 29

Object name: CompressorStatus_XXX (XXX represents the air conditioner's group number.)

Object type: Binary input

Description: This object is used to monitor whether or not the compressor of the outdoor unit connected to the indoor unit is operating.

Present_Value property:

ACTIVE: Compressor of the outdoor unit connected to the air conditioner is operating.

INACTIVE: Compressor of the outdoor unit connected to the air conditioner is stopped.

11.29 Indoor Fan Status

Member number: 30

Object name: IndoorFanStatus_XXX (XXX represents the air conditioner's group number.)

Object type: Binary input

Description: This object is used to monitor whether or not the air conditioner's fan is operating.

Present_Value property:

ACTIVE: Indoor fan is operating.

INACTIVE: Indoor fan is stopped.

11.30 Heater Operation Status

Member number: 31

Object name: HeaterStatus_XXX (XXX represents the air conditioner's group number.)

Object type: Binary input

Description: This object is used to monitor whether or not the indoor unit's built-in heater is operating.

Present_Value property:

ACTIVE: Air conditioner's built-in heater is operating.

INACTIVE: Air conditioner's built-in heater is stopped.

CB07A004G

11.31 Ventilation Mode (Setting)

Member number: 32

Object name: VentilationModeCommand_XXX (XXX represents the air conditioner's group number.)

Object type: Multistate Output

Description: This object is used to set a Heat Reclaim Ventilator's Ventilation Mode.

Present_Value property:

1: Bypass

2: ERVentilation

3:Auto

Notes:

- (1) Equipments, which are incompatible with Ventilation Mode "Auto", cannot be set to "Auto" even if the command is sent. Instead, they may be switched to a different Mode.
- (2) If a remote controller group is used, Ventilation mode setting is not available for the controllers other than the master remote controller (i.e., child controllers).
Although each of other air conditioners other than the one with the master remote controller has this object, do not use it for mapping on other BACnet® devices.

11.32 Ventilation Mode (Status)

Member number: 33

Object name: VentilationModeStatus_XXX (XXX represents the air conditioner's group number.)

Object type: Multistate Input

Description: This object is used to monitor a Heat Reclaim Ventilator's Ventilation Mode.

Present_Value property:

1: Bypass

2: ERVentilation

3:Auto

Notes:

- (1) If a remote controller group is used, Ventilation mode(status) monitor is not available for the controllers other than the master remote controller (i.e., child controllers).
Although each of other air conditioners other than the one with the master remote controller has this object, do not use it for mapping on other BACnet® devices.

CB07A004G

11.33 Ventilation Amount (Setting)

Member number: 34

Object name: VentilationAmountCommand_XXX (XXX represents the air conditioner's group number.)

Object type: Multistate Output

Description: This object is used to set a Heat Reclaim Ventilator's Ventilation Amount.

Present_Value property:

1: Low

2: High

3: Auto

4: Low(fresh up)

5: High(fresh up)

6: Auto(fresh up)

Notes:

- (1) Equipments, which are incompatible with Ventilation Amount "Auto", cannot be set to "Auto" even if the command is sent. Instead, they may be switched to a different value.
- (2) The "fresh up" setting is disabled even if it is set for equipments which are incompatible with the Ventilation Amount "fresh up" function.
- (3) If a remote controller group is used, Ventilation amount setting is not available for the controllers other than the master remote controller (i.e., child controllers).
Although each of other air conditioners other than the one with the master remote controller has this object, do not use it for mapping on other BACnet® devices.

11.34 Ventilation Amount (Status)

Member number: 35

Object name: VentilationAmountStatus_XXX (XXX represents the air conditioner's group number.)

Object type: Multistate Input

Description: This object is used to monitor a Heat Reclaim Ventilator's Ventilation Amount..

Present_Value property:

1: Low

2: High

3: Auto

4: Low(fresh up)

5: High(fresh up)

6: Auto(fresh up)

Notes:

- (1) If a remote controller group is used, Ventilation Amount(status) monitor is not available for the controllers other than the master remote controller (i.e., child controllers).
Although each of other air conditioners other than the one with the master remote controller has this object, do not use it for mapping on other BACnet® devices.

CB07A004G

12. Others

12.1 Initial Status at Start-up

Since the system automatically recognizes connected air conditioners, approximately 1 minute is required to recognize them after power on. During this period, accessing a connected air conditioner may return ErrorPDU of ErrorClass = OBJECT, ErrorCode = UNKNOWN_OBJECT.

Also, trying to read the ObjectList property of the Device object during this period will return ErrorPDU of ErrorClass = DEVICE, ErrorCode = CONFIGURATION_IN_PROGRESS if the air conditioner has not been recognized. At this time, the System_Status property of the Device object is DOWNLOAD_IN_PROGRESS, and it will change to OPERATIONAL when the air conditioner has been recognized.

12.2 BACnet® Network Layer

Although the BACnet® network layer address can be specified, the total number of BACnet® networks available for communication is limited to 100.

12.3 Time Adjustment

Use the TimeSynconization service to adjust the time with local time, and the UTCTimeSynconization service to adjust the time with UTC standard time.

The Trial Operation tool allows to specify a time difference.

12.4 Device Communication Control Service

- (1) Supported version
Ver.6.20 or later

- (2) Service parameters
Supported and unsupported DeviceCommunicationControl service parameters are shown below. Refer to the BACnet® standard specifications for the details of the parameters.

Parameter	Supported/unsupported	Note
TimeDuration parameter	Supported	-
Enable/disable parameter	Supported	-
Password parameter	Unsupported	Password is ignored even if specified.

- (3) Note: If no response is sent back for BACnet® request
If no response is sent back for a BACnet® request even when the device is powered on and the ping command returns a response (i.e., the network connection is established), BACnetGateway's BACnetcommunication is disabled by the DeviceCommunicationControl service. In this case, use the DeviceCommunicationControl service to enable the communication.

CB07A004G

[Reference]

Mapping between the Present_Value properties and failure codes of the malfunction code object

PV	Code	PV	Code	PV	Code	PV	Code	PV	Code	PV	Code	PV	Code	PV	Code	PV	Code
1	00	49	E0	97	J0	145	U0	193	70	241	40	289	10	337	M0	385	T0
2	01	50	E1	98	J1	146	U1	194	71	242	41	290	11	338	M1	386	T1
3	02	51	E2	99	J2	147	U2	195	72	243	42	291	12	339	M2	387	T2
4	03	52	E3	100	J3	148	U3	196	73	244	43	292	13	340	M3	388	T3
5	04	53	E4	101	J4	149	U4	197	74	245	44	293	14	341	M4	389	T4
6	05	54	E5	102	J5	150	U5	198	75	246	45	294	15	342	M5	390	T5
7	06	55	E6	103	J6	151	U6	199	76	247	46	295	16	343	M6	391	T6
8	07	56	E7	104	J7	152	U7	200	77	248	47	296	17	344	M7	392	T7
9	08	57	E8	105	J8	153	U8	201	78	249	48	297	18	345	M8	393	T8
10	09	58	E9	106	J9	154	U9	202	79	250	49	298	19	346	M9	394	T9
11	0A	59	EA	107	JA	155	UA	203	7A	251	4A	299	1A	347	MA	395	TA
12	0H	60	EH	108	JH	156	UH	204	7H	252	4H	300	1H	348	MH	396	TH
13	0C	61	EC	109	JC	157	UC	205	7C	253	4C	301	1C	349	MC	397	TC
14	0J	62	EJ	110	JJ	158	UJ	206	7J	254	4J	302	1J	350	MJ	398	TJ
15	0E	63	EE	111	JE	159	UE	207	7E	255	4E	303	1E	351	ME	399	TE
16	0F	64	EF	112	JF	160	UF	208	7F	256	4F	304	1F	352	MF	400	TF
17	A0	65	H0	113	L0	161	90	209	60	257	30	305	G0	353	N0	401	V0
18	A1	66	H1	114	L1	162	91	210	61	258	31	306	G1	354	N1	402	V1
19	A2	67	H2	115	L2	163	92	211	62	259	32	307	G2	355	N2	403	V2
20	A3	68	H3	116	L3	164	93	212	63	260	33	308	G3	356	N3	404	V3
21	A4	69	H4	117	L4	165	94	213	64	261	34	309	G4	357	N4	405	V4
22	A5	70	H5	118	L5	166	95	214	65	262	35	310	G5	358	N5	406	V5
23	A6	71	H6	119	L6	167	96	215	66	263	36	311	G6	359	N6	407	V6
24	A7	72	H7	120	L7	168	97	216	67	264	37	312	G7	360	N7	408	V7
25	A8	73	H8	121	L8	169	98	217	68	265	38	313	G8	361	N8	409	V8
26	A9	74	H9	122	L9	170	99	218	69	266	39	314	G9	362	N9	410	V9
27	AA	75	HA	123	LA	171	9A	219	6A	267	3A	315	GA	363	NA	411	VA
28	AH	76	HH	124	LH	172	9H	220	6H	268	3H	316	GH	364	NH	412	VH
29	AC	77	HC	125	LC	173	9C	221	6C	269	3C	317	GC	365	NC	413	VC
30	AJ	78	HJ	126	LJ	174	9J	222	6J	270	3J	318	GJ	366	NJ	414	VJ
31	AE	79	HE	127	LE	175	9E	223	6E	271	3E	319	GE	367	NE	415	VE
32	AF	80	HF	128	LF	176	9F	224	6F	272	3F	320	GF	368	NF	416	VF
33	C0	81	F0	129	P0	177	80	225	50	273	20	321	K0	369	R0	417	W0
34	C1	82	F1	130	P1	178	81	226	51	274	21	322	K1	370	R1	418	W1
35	C2	83	F2	131	P2	179	82	227	52	275	22	323	K2	371	R2	419	W2
36	C3	84	F3	132	P3	180	83	228	53	276	23	324	K3	372	R3	420	W3
37	C4	85	F4	133	P4	181	84	229	54	277	24	325	K4	373	R4	421	W4
38	C5	86	F5	134	P5	182	85	230	55	278	25	326	K5	374	R5	422	W5
39	C6	87	F6	135	P6	183	86	231	56	279	26	327	K6	375	R6	423	W6
40	C7	88	F7	136	P7	184	87	232	57	280	27	328	K7	376	R7	424	W7
41	C8	89	F8	137	P8	185	88	233	58	281	28	329	K8	377	R8	425	W8
42	C9	90	F9	138	P9	186	89	234	59	282	29	330	K9	378	R9	426	W9
43	CA	91	FA	139	PA	187	8A	235	5A	283	2A	331	KA	379	RA	427	WA
44	CH	92	FH	140	PH	188	8H	236	5H	284	2H	332	KH	380	RH	428	WH
45	CC	93	FC	141	PC	189	8C	237	5C	285	2C	333	KC	381	RC	429	WC
46	CJ	94	FJ	142	PJ	190	8J	238	5J	286	2J	334	KJ	382	RJ	430	WJ
47	CE	95	FE	143	PE	191	8E	239	5E	287	2E	335	KE	383	RE	431	WE
48	CF	96	FF	144	PF	192	8F	240	5F	288	2F	336	KF	384	RF	432	WF

481 - 512 are reserved.

CB07A004G

13. Appendix A: PICS (D-BACS Interface for use in BACnet® Ver. 6.10)

13.1 BACnet® Protocol Implementation Conformance Statement

Date: Nov. 15, 2006

Vendor Name: DAIKIN INDUSTRIES, Ltd.

Product Name: D-BACS Interface for use in BACnet®

Product Model Number: DMS502B51, DMS502B71

Applications Software Version: 6.10.00 Firmware Revision: 000.001 BACnet Protocol Revision: 4

Product Description:

This product provides the function of monitoring and operating the air-conditioner. The supported Data Link Layer Options are BACnet/IP.

BACnet Standardized Device Profile (Annex L):

- BACnet Operator Workstation (B-OWS)
- BACnet Building Controller (B-BC)
- BACnet Advanced Application Controller (B-AAC)
- BACnet Application Specific Controller (B-ASC)
- BACnet Smart Sensor (B-SS)
- BACnet Smart Actuator (B-SA)

BACnet Interoperability Building Blocks Supported (Annex K):

	Supported BIBBs	BIBB Name	Supported
Data Sharing	DS-RP-B	Data Sharing-ReadProperty-B	■
	DS-RPM-B	Data Sharing-ReadPropertyMultiple-B	■
	DS-WP-B	Data Sharing-WriteProperty-B	■
	DS-WPM-B	Data Sharing-WritePropertyMultiple-B	■
	DS-COV-B	Data Sharing-COV-B	■
	DS-COVU-B	Data Sharing-COV-Unsolicited-B	■
Alarm and Event Management	AE-N-I-B	Alarm and Event-Notification Internal-B	■
Device Management	DM-DDB-A	Device Management-Dynamic Device Binding-A	■
	DM-DDB-B	Device Management-Dynamic Device Binding-B	■
	DM-DOB-B	Device Management-Dynamic Object Binding-B	■
	DM-TS-B	Device Management-Time Synchronization-B	■
	DM-UTC-B	Device Management-UTCTimeSynchronization-B	■
	DM-LM-B	Device Management-List Manipulation-B	■

CB07A004G

Standard Object Types Supported:**(1) Accumulator**

Dynamically Creatable:	No
Dynamically Deletable:	No
Optional Properties Supported:	Reliability
Writable Properties:	n/a
Proprietary Properties:	n/a
Property Range Restrictions:	n/a

(2) Analog Input**a) Room Temperature**

Dynamically Creatable:	No
Dynamically Deletable:	No
Optional Properties Supported:	Reliability, COV_Increment, Time_Delay, Notification_Class, High_Limit, Low_Limit, Deadband , Limit_Enable, Event_Enable, Acked_Transitions, Notify_Type, Event_Time_Stamps
Writable Properties:	High_Limit, Low_Limit, Deadband , Limit_Enable
Proprietary Properties:	n/a
Property Range Restrictions:	n/a

b) Others

Dynamically Creatable:	No
Dynamically Deletable:	No
Optional Properties Supported:	Reliability, COV_Increment,
Writable Properties:	n/a
Proprietary Properties:	n/a
Property Range Restrictions:	n/a

(3) Analog Value

Dynamically Creatable:	No
Dynamically Deletable:	No
Optional Properties Supported:	Reliability, Priority_Array, Relinquish_Default, COV_Increment
Writable Properties:	Present_Value
Proprietary Properties:	n/a
Property Range Restrictions:	n/a

CB07A004G

(4) Binary Input**a) Alarm Sign, Filter Limit Sign**

Dynamically Creatable:	No
Dynamically Deletable:	No
Optional Properties Supported:	Reliability, Description (Only Alarm Sign supports), Time_Delay, Notification_Class, Alarm_Value, Event_Enable, Acked_Transitions, Notify_Type, Event_Time_Stamps
Writable Properties:	n/a
Proprietary Properties:	n/a
Property Range Restrictions:	n/a

b) ON/OFF (Status)

Dynamically Creatable:	No
Dynamically Deletable:	No
Optional Properties Supported:	Reliability, Change_Of_State_Time, Change_Of_State_Count, Time_Of_State_Count_Reset, Elapsed_Active_Time, Time_Of_Active_Time_Reset
Writable Properties:	n/a
Proprietary Properties:	n/a
Property Range Restrictions:	n/a

c) Others

Dynamically Creatable:	No
Dynamically Deletable:	No
Optional Properties Supported:	Reliability
Writable Properties:	n/a
Proprietary Properties:	n/a
Property Range Restrictions:	n/a

CB07A004G

(5) Binary Output

Dynamically Creatable:	No
Dynamically Deletable:	No
Optional Properties Supported:	Reliability,
Writable Properties:	Present_Value
Proprietary Properties:	n/a
Property Range Restrictions:	n/a

(6) Binary Value**a) Filter Limit Sign Reset**

Dynamically Creatable:	No
Dynamically Deletable:	No
Optional Properties Supported:	Reliability, Priority_Array, Relinquish_Default, Time_Delay, Notification_Class, Alarm_Value, Event_Enable, Acked_Transitions, Notify_Type, Event_Time_Stamps
Writable Properties:	Present_Value
Proprietary Properties:	n/a
Property Range Restrictions:	n/a

b) Others

Dynamically Creatable:	No
Dynamically Deletable:	No
Optional Properties Supported:	Reliability, Priority_Array, Relinquish_Default
Writable Properties:	Present_Value
Proprietary Properties:	n/a
Property Range Restrictions:	n/a

(7) Device

Dynamically Creatable:	No
Dynamically Deletable:	No
Optional Properties Supported:	Max_Segment_Accepted, Local_Time, Local_Date, UTC_Offset, Daylight_Saving_Status, APDU_Segment_Timeout
Writable Properties:	n/a
Proprietary Properties:	n/a
Property Range Restrictions:	n/a

CB07A004G

(8) Multi-state Input

Dynamically Creatable:	No
Dynamically Deletable:	No
Optional Properties Supported:	Reliability, Description (Only Error Code supports.)
Writable Properties:	n/a
Proprietary Properties:	n/a
Property Range Restrictions:	n/a

(9) Multi-state Output

Dynamically Creatable:	No
Dynamically Deletable:	No
Optional Properties Supported:	Reliability
Writable Properties:	Present_Value
Proprietary Properties:	n/a
Property Range Restrictions:	n/a

(10) Notification Class

Dynamically Creatable:	No
Dynamically Deletable:	No
Optional Properties Supported:	n/a
Writable Properties:	Recipient_List
Proprietary Properties:	n/a
Property Range Restrictions:	n/a

CB07A004G

Data Link Layer Options:

- BACnet IP, (Annex J)
- BACnet IP, (Annex J), Foreign Device
- ISO 8802-3, Ethernet (Clause 7)
- ANSI/ATA 878.1, 2.5 Mb. ARCNET (Clause 8)
- ANSI/ATA 878.1, RS-485 ARCNET (Clause 8), baud rate(s) _____
- MS/TP master (Clause 9), baud rate(s): _____
- MS/TP slave (Clause 9), baud rate(s): _____
- Point-To-Point, EIA 232 (Clause 10), baud rate(s): _____
- Point-To-Point, modem, (Clause 10), baud rate(s): _____
- LonTalk, (Clause 11), medium: _____
- Other: _____

Device Address Binding:

Is static device binding supported? (This is currently necessary for two-way communication with MS/TP slaves and certain other devices.) Yes No

Networking Options:

- Router, Clause 6 - List all routing configurations, e.g., ARCNET-Ethernet, Ethernet-MS/TP, etc.
- Annex H, BACnet Tunneling Router over IP
- BACnet/IP Broadcast Management Device (BBMD)
 - Does the BBMD support registrations by Foreign Devices? Yes No

Character Sets Supported:

Indicating support for multiple character sets does not imply that they can all be supported simultaneously.

- ANSI X3.4 IBM™/Microsoft™ DBCS ISO 8859-1
- ISO 10646 (UCS-2) ISO 10646 (UCS-4) JIS C 6226

If this product is a communication gateway, describe the types of non-BACnet equipment/networks(s) that the gateway supports:

Not applicable.

CB07A004G

14. Appendix B: PICS (D-BACS Interface for use in BACnet® Ver. 6.20)

14.1 BACnet® Protocol Implementation Conformance Statement

Date: Nov. 15, 2006

Vendor Name: DAIKIN INDUSTRIES, Ltd.

Product Name: D-BACS Interface for use in BACnet®

Product Model Number: DMS502B51, DMS502B71

Applications Software Version: 6.20.00 Firmware Revision: 000.001 BACnet Protocol Revision: 4

Product Description:

This product provides the function of monitoring and operating the air-conditioner. The supported Data Link Layer Options are BACnet/IP.

BACnet Standardized Device Profile (Annex L):

- BACnet Operator Workstation (B-OWS)
- BACnet Building Controller (B-BC)
- BACnet Advanced Application Controller (B-AAC)
- BACnet Application Specific Controller (B-ASC)
- BACnet Smart Sensor (B-SS)
- BACnet Smart Actuator (B-SA)

BACnet Interoperability Building Blocks Supported (Annex K):

	Supported BIBBs	BIBB Name	Supported	
			Standard support	Optional support
Data Sharing	DS-RP-B	Data Sharing-ReadProperty-B	■	<input type="checkbox"/>
	DS-RPM-B	Data Sharing-ReadPropertyMultiple-B	■	<input type="checkbox"/>
	DS-WP-B	Data Sharing-WriteProperty-B	■	<input type="checkbox"/>
	DS-WPM-B	Data Sharing-WritePropertyMultiple-B	■	<input type="checkbox"/>
	DS-COV-B	Data Sharing-COV-B	■	<input type="checkbox"/>
	DS-COVU-B	Data Sharing-COV-Unsolicited-B	■	<input type="checkbox"/>
Alarm and Event Management	AE-N-I-B	Alarm and Event-Notification Internal-B	<input type="checkbox"/>	■
Device Management	DM-DDB-A	Device Management-Dynamic Device Binding-A	■	<input type="checkbox"/>
	DM-DDB-B	Device Management-Dynamic Device Binding-B	■	<input type="checkbox"/>
	DM-DOB-B	Device Management-Dynamic Object Binding-B	■	<input type="checkbox"/>
	DM-DCC-B	Device Management-DeviceCommunicationControl-B	■	<input type="checkbox"/>
	DM-TS-B	Device Management-Time Synchronization-B	■	<input type="checkbox"/>
	DM-UTC-B	Device Management-UTCTimeSynchronization-B	■	<input type="checkbox"/>
	DM-LM-B	Device Management-List Manipulation-B	<input type="checkbox"/>	■

※In a default setting, AE-N-I-B and DM-LM-B are invalid. They become valid after setting by a setup tool for a service man.

CB07A004G

Standard Object Types Supported:**(1) Accumulator**

Dynamically Creatable:	No
Dynamically Deletable:	No
Optional Properties Supported:	Reliability
Writable Properties:	n/a
Proprietary Properties:	n/a
Property Range Restrictions:	n/a

(2) Analog Input**a) Room Temperature**

Dynamically Creatable:	No
Dynamically Deletable:	No
Optional Properties Supported:	Reliability, COV_Increment, (Time_Delay, Notification_Class, High_Limit, Low_Limit, Deadband , Limit_Enable, Event_Enable, Acked_Transitions, Notify_Type, Event_Time_Stamps) ※These properties are supported when intrinsic reporting is valid.
Writable Properties:	(High_Limit, Low_Limit, Deadband , Limit_Enable) ※These properties are supported when intrinsic reporting is valid.
Proprietary Properties:	n/a
Property Range Restrictions:	n/a

b) Others

Dynamically Creatable:	No
Dynamically Deletable:	No
Optional Properties Supported:	Reliability, COV_Increment
Writable Properties:	n/a
Proprietary Properties:	n/a
Property Range Restrictions:	n/a

(3) Analog Value

Dynamically Creatable:	No
Dynamically Deletable:	No
Optional Properties Supported:	Reliability, Priority_Array, Relinquish_Default, COV_Increment
Writable Properties:	Present_Value
Proprietary Properties:	n/a
Property Range Restrictions:	n/a

CB07A004G

(4) Binary Input**a) Alarm Sign, Filter Limit Sign**

Dynamically Creatable:	No
Dynamically Deletable:	No
Optional Properties Supported:	Reliability, Description (Only Alarm Sign supports), (Time_Delay, Notification_Class, Alarm_Value, Event_Enable, Acked_Transitions, Notify_Type, Event_Time_Stamps) ※These properties are supported when intrinsic reporting is valid.
Writable Properties:	n/a
Proprietary Properties:	n/a
Property Range Restrictions:	n/a

b) ON/OFF (Status)

Dynamically Creatable:	No
Dynamically Deletable:	No
Optional Properties Supported:	Reliability, Change_Of_State_Time, Change_Of_State_Count, Time_Of_State_Count_Reset, Elapsed_Active_Time, Time_Of_Active_Time_Reset
Writable Properties:	n/a
Proprietary Properties:	n/a
Property Range Restrictions:	n/a

c) Others

Dynamically Creatable:	No
Dynamically Deletable:	No
Optional Properties Supported:	Reliability
Writable Properties:	n/a
Proprietary Properties:	n/a
Property Range Restrictions:	n/a

CB07A004G

(5) Binary Output

Dynamically Creatable:	No
Dynamically Deletable:	No
Optional Properties Supported:	Reliability,
Writable Properties:	Present_Value
Proprietary Properties:	n/a
Property Range Restrictions:	n/a

(6) Binary Value**a) Filter Limit Sign Reset**

Dynamically Creatable:	No
Dynamically Deletable:	No
Optional Properties Supported:	Reliability, Priority_Array, Relinquish_Default, (Time_Delay, Notification_Class, Alarm_Value, Event_Enable, Acked_Transitions, Notify_Type, Event_Time_Stamps) ※These properties are supported when intrinsic reporting is valid.
Writable Properties:	Present_Value
Proprietary Properties:	n/a
Property Range Restrictions:	n/a

b) Others

Dynamically Creatable:	No
Dynamically Deletable:	No
Optional Properties Supported:	Reliability, Priority_Array, Relinquish_Default
Writable Properties:	Present_Value
Proprietary Properties:	n/a
Property Range Restrictions:	n/a

(7) Device

Dynamically Creatable:	No
Dynamically Deletable:	No
Optional Properties Supported:	Max_Segment_Accepted, Local_Time, Local_Date, UTC_Offset, Daylight_Saving_Status, APDU_Segment_Timeout, Active_COV_Subscriptions
Writable Properties:	n/a
Proprietary Properties:	n/a
Property Range Restrictions:	n/a

CB07A004G

(8) Multi-state Input

Dynamically Creatable:	No
Dynamically Deletable:	No
Optional Properties Supported:	Reliability, Description (Only Error Code supports.)
Writable Properties:	n/a
Proprietary Properties:	n/a
Property Range Restrictions:	n/a

(9) Multi-state Output

Dynamically Creatable:	No
Dynamically Deletable:	No
Optional Properties Supported:	Reliability
Writable Properties:	Present_Value
Proprietary Properties:	n/a
Property Range Restrictions:	n/a

(10) Notification Class

Dynamically Creatable:	No
Dynamically Deletable:	No
Optional Properties Supported:	n/a
Writable Properties:	Recipient_List
Proprietary Properties:	n/a
Property Range Restrictions:	n/a

※Notification Class Object exists when intrinsic reporting is valid.

CB07A004G

Data Link Layer Options:

- BACnet IP, (Annex J)
- BACnet IP, (Annex J), Foreign Device
- ISO 8802-3, Ethernet (Clause 7)
- ANSI/ATA 878.1, 2.5 Mb. ARCNET (Clause 8)
- ANSI/ATA 878.1, RS-485 ARCNET (Clause 8), baud rate(s) _____
- MS/TP master (Clause 9), baud rate(s): _____
- MS/TP slave (Clause 9), baud rate(s): _____
- Point-To-Point, EIA 232 (Clause 10), baud rate(s): _____
- Point-To-Point, modem, (Clause 10), baud rate(s): _____
- LonTalk, (Clause 11), medium: _____
- Other: _____

Device Address Binding:

Is static device binding supported? (This is currently necessary for two-way communication with MS/TP slaves and certain other devices.) Yes No

Networking Options:

- Router, Clause 6 - List all routing configurations, e.g., ARCNET-Ethernet, Ethernet-MS/TP, etc.
- Annex H, BACnet Tunneling Router over IP
- BACnet/IP Broadcast Management Device (BBMD)
 - Does the BBMD support registrations by Foreign Devices? Yes No

Character Sets Supported:

Indicating support for multiple character sets does not imply that they can all be supported simultaneously.

- ANSI X3.4 IBM™/Microsoft™ DBCS ISO 8859-1
- ISO 10646 (UCS-2) ISO 10646 (UCS-4) JIS C 6226

If this product is a communication gateway, describe the types of non-BACnet equipment/networks(s) that the gateway supports:

Not applicable

CB07A004G

15. Appendix C: PICS (D-BACS Interface for use in BACnet® Ver. 6.30)

15.1 BACnet® Protocol Implementation Conformance Statement

Date: Feb. 03, 2009

Vendor Name: DAIKIN INDUSTRIES, Ltd.

Product Name: D-BACS BACnet Gateway

Product Model Number: DMS502B51, DMS502B71

Applications Software Version: 6.30.00 Firmware Revision: 000.001 BACnet Protocol Revision: 4

Product Description:

This product provides the function of monitoring and operating the air-conditioner. The supported Data Link Layer Options are BACnet/IP.

BACnet Standardized Device Profile (Annex L):

- BACnet Operator Workstation (B-OWS)
- BACnet Building Controller (B-BC)
- BACnet Advanced Application Controller (B-AAC)
- BACnet Application Specific Controller (B-ASC)
- BACnet Smart Sensor (B-SS)
- BACnet Smart Actuator (B-SA)

BACnet Interoperability Building Blocks Supported (Annex K):

	Supported BIBBs	BIBB Name	Supported	
			Standard support	Optional support
Data Sharing	DS-RP-B	Data Sharing-ReadProperty-B	■	<input type="checkbox"/>
	DS-RPM-B	Data Sharing-ReadPropertyMultiple-B	■	<input type="checkbox"/>
	DS-WP-B	Data Sharing-WriteProperty-B	■	<input type="checkbox"/>
	DS-WPM-B	Data Sharing-WritePropertyMultiple-B	■	<input type="checkbox"/>
	DS-COV-B	Data Sharing-COV-B	■	<input type="checkbox"/>
	DS-COVU-B	Data Sharing-COV-Unsolicited-B	■	<input type="checkbox"/>
Alarm and Event Management	AE-N-I-B	Alarm and Event-Notification Internal-B	<input type="checkbox"/>	■
Device Management	DM-DDB-A	Device Management-Dynamic Device Binding-A	■	<input type="checkbox"/>
	DM-DDB-B	Device Management-Dynamic Device Binding-B	■	<input type="checkbox"/>
	DM-DOB-B	Device Management-Dynamic Object Binding-B	■	<input type="checkbox"/>
	DM-DCC-B	Device Management-DeviceCommunicationControl-B	■	<input type="checkbox"/>
	DM-TS-B	Device Management-Time Synchronization-B	■	<input type="checkbox"/>
	DM-UTC-B	Device Management-UTCTimeSynchronization-B	■	<input type="checkbox"/>
	DM-LM-B	Device Management-List Manipulation-B	<input type="checkbox"/>	■

※In a default setting, AE-N-I-B and DM-LM-B are invalid. They become valid after setting by a setup tool for a service man.

CB07A004G

Standard Object Types Supported:**(1) Accumulator**

Dynamically Creatable:	No
Dynamically Deletable:	No
Optional Properties Supported:	Reliability
Writable Properties:	n/a
Proprietary Properties:	n/a
Property Range Restrictions:	n/a

(2) Analog Input**a) Room Temperature**

Dynamically Creatable:	No
Dynamically Deletable:	No
Optional Properties Supported:	Reliability, COV_Increment, (Time_Delay, Notification_Class, High_Limit, Low_Limit, Deadband , Limit_Enable, Event_Enable, Acked_Transitions, Notify_Type, Event_Time_Stamps) ※These properties are supported when intrinsic reporting is valid.
Writable Properties:	(High_Limit, Low_Limit, Deadband , Limit_Enable) ※These properties are supported when intrinsic reporting is valid.
Proprietary Properties:	n/a
Property Range Restrictions:	n/a

b) Others

Dynamically Creatable:	No
Dynamically Deletable:	No
Optional Properties Supported:	Reliability, COV_Increment
Writable Properties:	n/a
Proprietary Properties:	n/a
Property Range Restrictions:	n/a

(3) Analog Value

Dynamically Creatable:	No
Dynamically Deletable:	No
Optional Properties Supported:	Reliability, Priority_Array, Relinquish_Default, COV_Increment
Writable Properties:	Present_Value
Proprietary Properties:	n/a
Property Range Restrictions:	n/a

CB07A004G

(4) Binary Input**a) Alarm Sign, Filter Limit Sign**

Dynamically Creatable:	No
Dynamically Deletable:	No
Optional Properties Supported:	Reliability, Description (Only Alarm Sign supports), (Time_Delay, Notification_Class, Alarm_Value, Event_Enable, Acked_Transitions, Notify_Type, Event_Time_Stamps) ※These properties are supported when intrinsic reporting is valid.
Writable Properties:	n/a
Proprietary Properties:	n/a
Property Range Restrictions:	n/a

b) ON/OFF (Status)

Dynamically Creatable:	No
Dynamically Deletable:	No
Optional Properties Supported:	Reliability, Change_Of_State_Time, Change_Of_State_Count, Time_Of_State_Count_Reset, Elapsed_Active_Time, Time_Of_Active_Time_Reset
Writable Properties:	n/a
Proprietary Properties:	n/a
Property Range Restrictions:	n/a

c) Others

Dynamically Creatable:	No
Dynamically Deletable:	No
Optional Properties Supported:	Reliability
Writable Properties:	n/a
Proprietary Properties:	n/a
Property Range Restrictions:	n/a

CB07A004G

(5) Binary Output

Dynamically Creatable:	No
Dynamically Deletable:	No
Optional Properties Supported:	Reliability
Writable Properties:	Present_Value
Proprietary Properties:	n/a
Property Range Restrictions:	n/a

(6) Binary Value**a) Filter Limit Sign Reset**

Dynamically Creatable:	No
Dynamically Deletable:	No
Optional Properties Supported:	Reliability, Priority_Array, Relinquish_Default, (Time_Delay, Notification_Class, Alarm_Value, Event_Enable, Acked_Transitions, Notify_Type, Event_Time_Stamps) ※These properties are supported when intrinsic reporting is valid.
Writable Properties:	Present_Value
Proprietary Properties:	n/a
Property Range Restrictions:	n/a

b) Others

Dynamically Creatable:	No
Dynamically Deletable:	No
Optional Properties Supported:	Reliability, Priority_Array, Relinquish_Default
Writable Properties:	Present_Value
Proprietary Properties:	n/a
Property Range Restrictions:	n/a

(7) Device

Dynamically Creatable:	No
Dynamically Deletable:	No
Optional Properties Supported:	Max_Segment_Accepted, Local_Time, Local_Date, UTC_Offset, Daylight_Saving_Status, APDU_Segment_Timeout, Active_COV_Subscriptions
Writable Properties:	n/a
Proprietary Properties:	n/a
Property Range Restrictions:	n/a

CB07A004G

(8) Multi-state Input

Dynamically Creatable:	No
Dynamically Deletable:	No
Optional Properties Supported:	Reliability, Description (Only Error Code supports.)
Writable Properties:	n/a
Proprietary Properties:	n/a
Property Range Restrictions:	n/a

(9) Multi-state Output

Dynamically Creatable:	No
Dynamically Deletable:	No
Optional Properties Supported:	Reliability
Writable Properties:	Present_Value
Proprietary Properties:	n/a
Property Range Restrictions:	n/a

(10) Notification Class

Dynamically Creatable:	No
Dynamically Deletable:	No
Optional Properties Supported:	n/a
Writable Properties:	Recipient_List
Proprietary Properties:	n/a
Property Range Restrictions:	n/a

※Notification Class Object exists when intrinsic reporting is valid.

CB07A004G

Data Link Layer Options:

- BACnet IP, (Annex J)
- BACnet IP, (Annex J), Foreign Device
- ISO 8802-3, Ethernet (Clause 7)
- ANSI/ATA 878.1, 2.5 Mb. ARCNET (Clause 8)
- ANSI/ATA 878.1, RS-485 ARCNET (Clause 8), baud rate(s) _____
- MS/TP master (Clause 9), baud rate(s): _____
- MS/TP slave (Clause 9), baud rate(s): _____
- Point-To-Point, EIA 232 (Clause 10), baud rate(s): _____
- Point-To-Point, modem, (Clause 10), baud rate(s): _____
- LonTalk, (Clause 11), medium: _____
- Other: _____

Device Address Binding:

Is static device binding supported? (This is currently necessary for two-way communication with MS/TP slaves and certain other devices.) Yes No

Networking Options:

- Router, Clause 6 - List all routing configurations, e.g., ARCNET-Ethernet, Ethernet-MS/TP, etc.
- Annex H, BACnet Tunneling Router over IP
- BACnet/IP Broadcast Management Device (BBMD)
 - Does the BBMD support registrations by Foreign Devices? Yes No

Character Sets Supported:

Indicating support for multiple character sets does not imply that they can all be supported simultaneously.

- ANSI X3.4
- IBM™/Microsoft™ DBCS
- ISO 8859-1
- ISO 10646 (UCS-2)
- ISO 10646 (UCS-4)
- JIS C 6226

If this product is a communication gateway, describe the types of non-BACnet equipment/networks(s) that the gateway supports:

Not applicable

CB07A004G

Part 3 Point List

1. BACnet[®] Point List.....86

1. BACnet® Point List

【What is a point list】

If connecting the AC to the central control board using the Interface for use in BACnet, it is necessary for the sales engineer in charge of objects to create a “point list” for each object and submit it to the central control board maker. The point list includes BACnet object information required when monitoring/controlling the AC from the central control board via the Interface for use in BACnet. The central control board maker creates an AC monitoring/control program for each object as per the items appearing in the point list.

The point list is determined as per the parameters below and created using a specially configured Excel file.

Parameter 1. DIII —NET address and ID name of AC connected to Interface for use in BACnet

Parameter 2. AC monitoring/control items executed by the central control board (documentation included in the table in Section (4) on P.209

Below is a description of how to create a point list.

(For objects where multiple Interface for use in BACnet will be delivered, a point list should be created for each Interface for use in BACnet.)

【How to create a point list】

The point list creation methods for the following monitoring/control objects are provided as examples.

Parameter 1. D3-NET address and ID name of AC connected to the Interface for use in BACnet.

- Address of AC connected to DIII port 1: 1-01 (name: 1F_Lobby)
- Address of AC connected to DIII port 2: 4-15 (name: 4F_Tenant2)

Parameter 2. AC monitoring/control items executed by the central control board (documentation included in the table in Section (4) on P.209)

Member Number	Standard Name	Object Type	Activation of central supervisory board monitoring/ control (Yes/No)
1	ON/OFF (setting)	BO	Yes
2	ON/OFF (status)	BI	Yes
3	Alarm Sign	BI	Yes
4	Error Code	MI	Yes
5	Operation Mode (setting)	MO	Yes
6	Operation Mode (status)	MI	Yes
7	Airflow Rate (setting)	MO	Yes
8	Airflow Rate (status)	MI	Yes
9	Measured Room Temperature	AI	Yes
10	Set Room Temperature	AV	Yes
11	Filer Limit Sign	BI	Yes
12	Filter Limit Sign Reset	BV	Yes
13	Remote Control Operation (ON/OFF)	BV	Yes
14	Remote Control Operation (Operation Mode)	BV	Yes
16	Remote Control Operation (Set Temperature)	BV	Yes
17	Remote Control Operation (Sub Group Address Control Rejection)	BV	No
19	Elec Total Power	Accumulator	No
20	Communication Status	BI	No
21	System Forced OFF	BV	Yes
22	Air Direction (setting)	AV	No
23	Air Direction (status)	AI	No
24	Forced Thermostat OFF (setting)	BO	No
25	Forced Thermostat OFF (status)	BI	No
26	Energy Efficiency Command (setting)	BO	No
27	Energy Efficiency Command (status)	BI	No
28	Thermostat Status	BI	No
29	Compressor Status	BI	No
30	Indoor Fan Status	BI	No
31	Heater Operation Status	BI	No
32	Ventilation mode(setting)	MO	Yes
33	Ventilation mode(status)	MI	Yes
34	Ventilation amount(setting)	MO	Yes
35	Ventilation amount(status)	MI	Yes

1. Launch point list creation tool

Filename: Copy MakePointList.xls and assign a unique name, such as the object name.

(Store this file and the final created point list data. Do not discard this data, as it may be required for future use, as when adding AC units.)

Double click on the file copied above will display the dialog box shown in Screen 1 below.

Click on (1) "Enable Macros". Then when Screen 2 is displayed, enter the Interface for use in BACnet device instance number from Section (2) on P.208 in (2).

The input method used for (3) (light blue cells) is described on the following pages.

Screen 1.

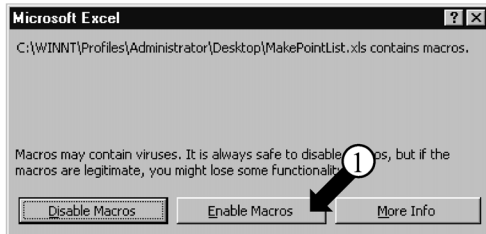

3

Screen 2. Point list creation tool default screen

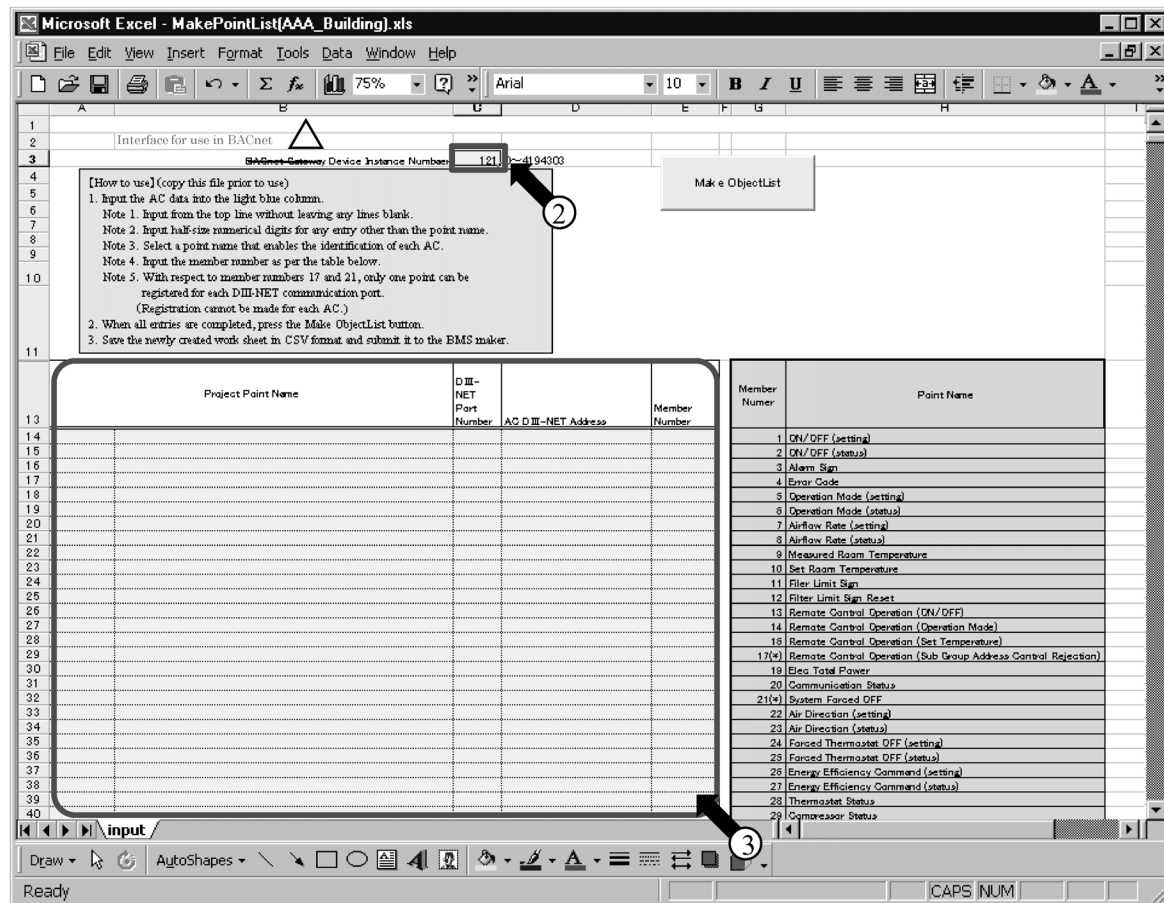

CB03A096C

- For items in the Parameter 2 table “AC monitoring/control items executed by the central control board” on P3 where the “Activation of central control board monitoring/control” column is set to “Yes”, use the procedure described below to enter the “Project Point Name”, “ DIII-NET Port Number”, “ AC DIII-NET Address”, and “ Member Number” in the order of AC addresses as they appear in the table.

Screen 2-1. Enter the Parameter 1 AC ID Name from P3 into (1).

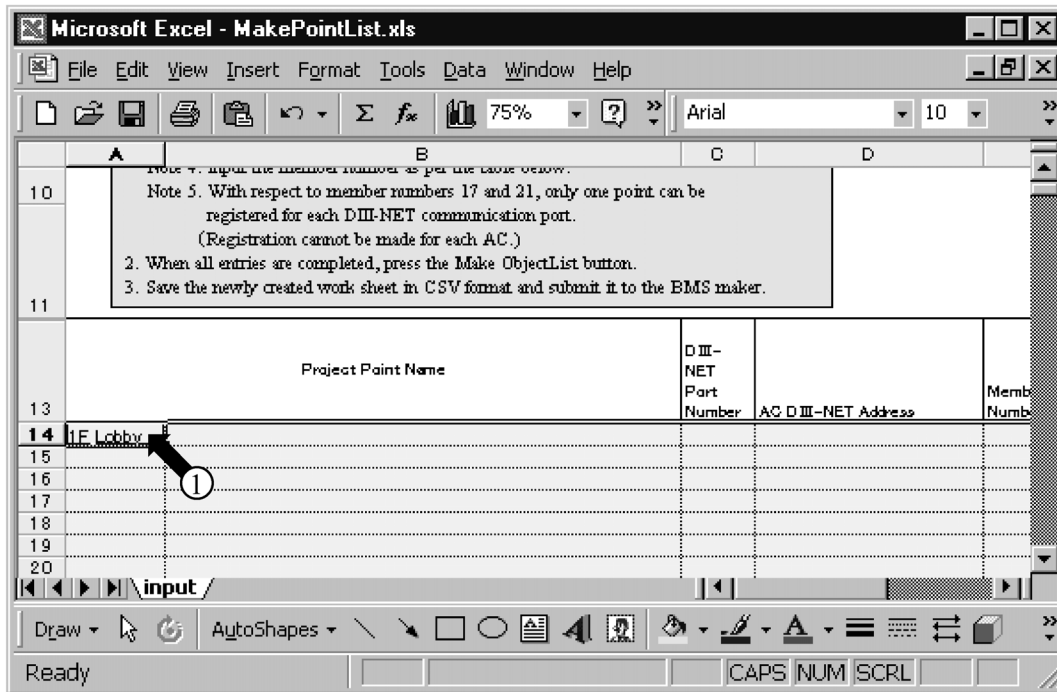

Screen 2-2. Enter the Parameter 2 Standard name from P3 into (2).

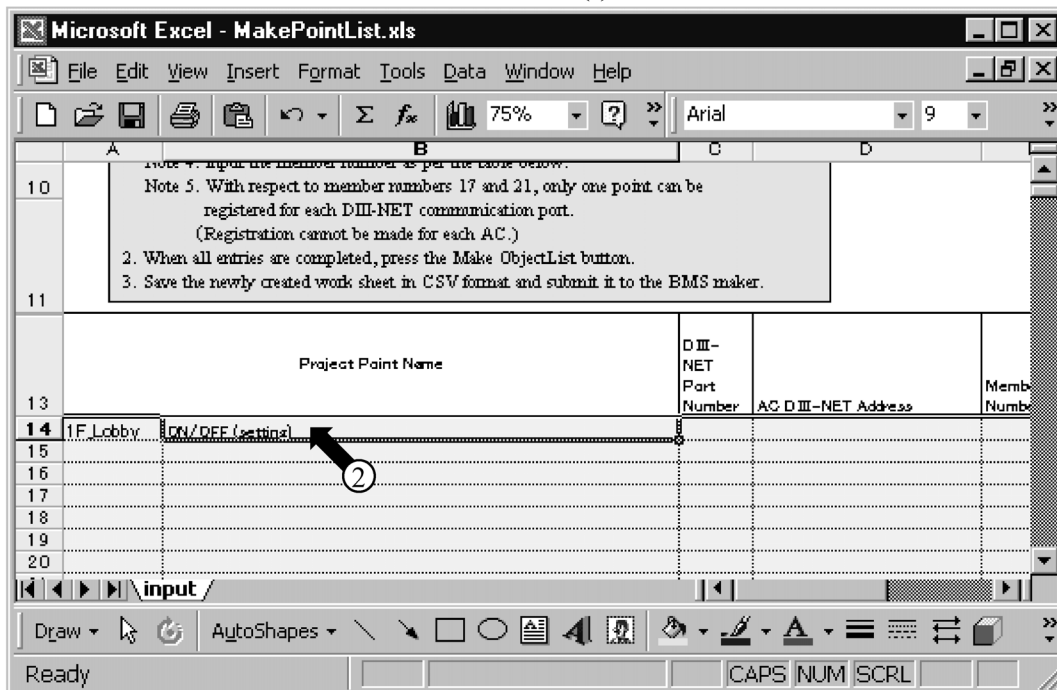

CB03A096C

Screen 2-3. Enter the Parameter 1 D3-NET Port Number from P3 into (3).

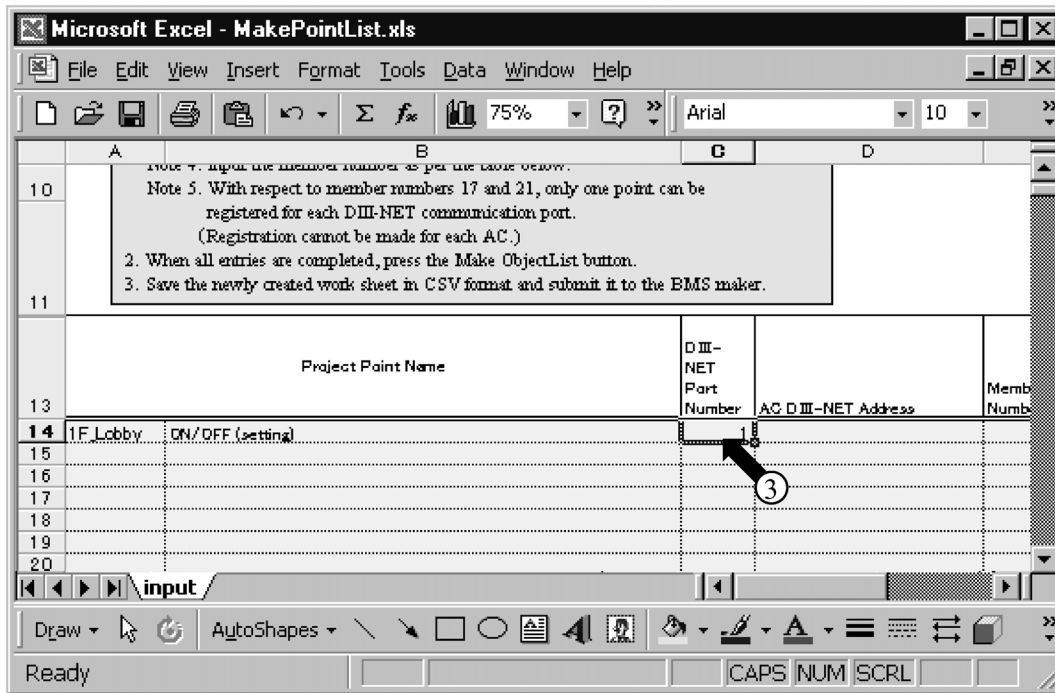

Screen 2-4. Enter the Parameter 1 AC D3-NET Address from P3 into (4).

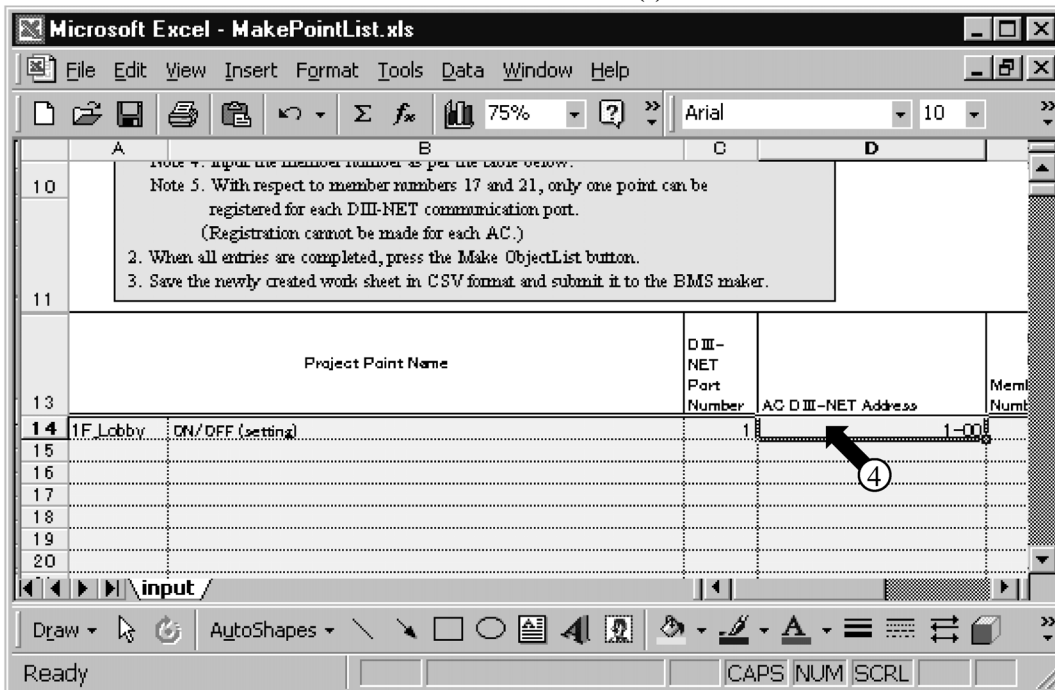

CB03A096C

Screen 2-5. Enter the Parameter 2 Member Number from P3 into (5). This completes one row of input.

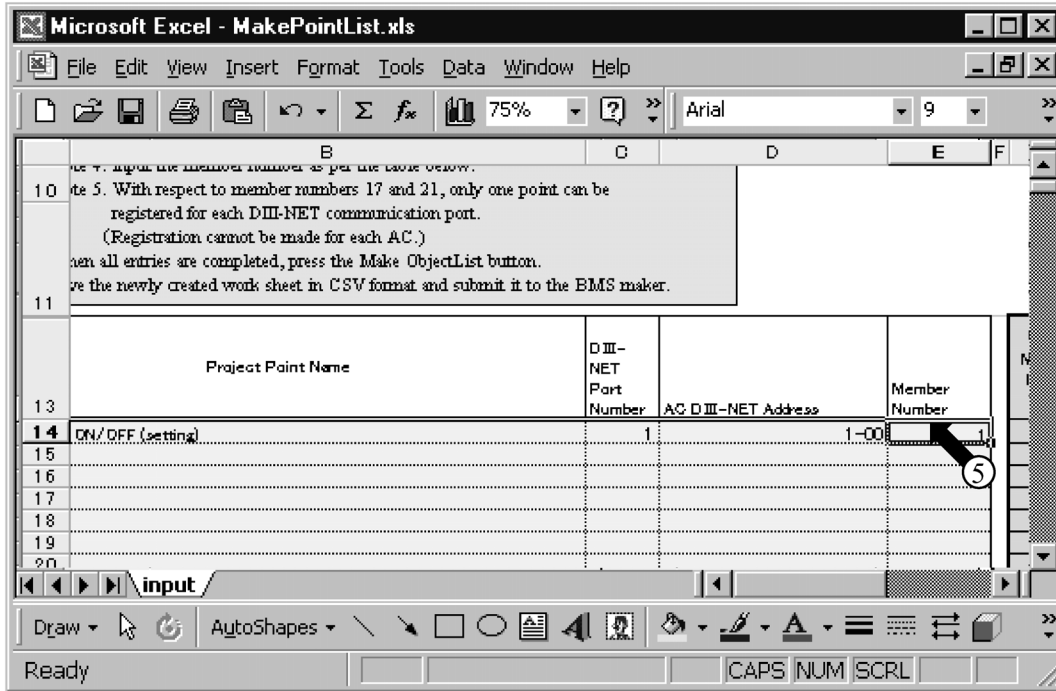

Screen 2-6. The screen will appear as illustrated below once steps 2-1 to 2-5 are repeated to enter all settings for the first AC unit. (At this time, excel's copy feature can be used to enter settings more efficiently.)
 Caution: Do not create any blank columns or lines while entering the settings.

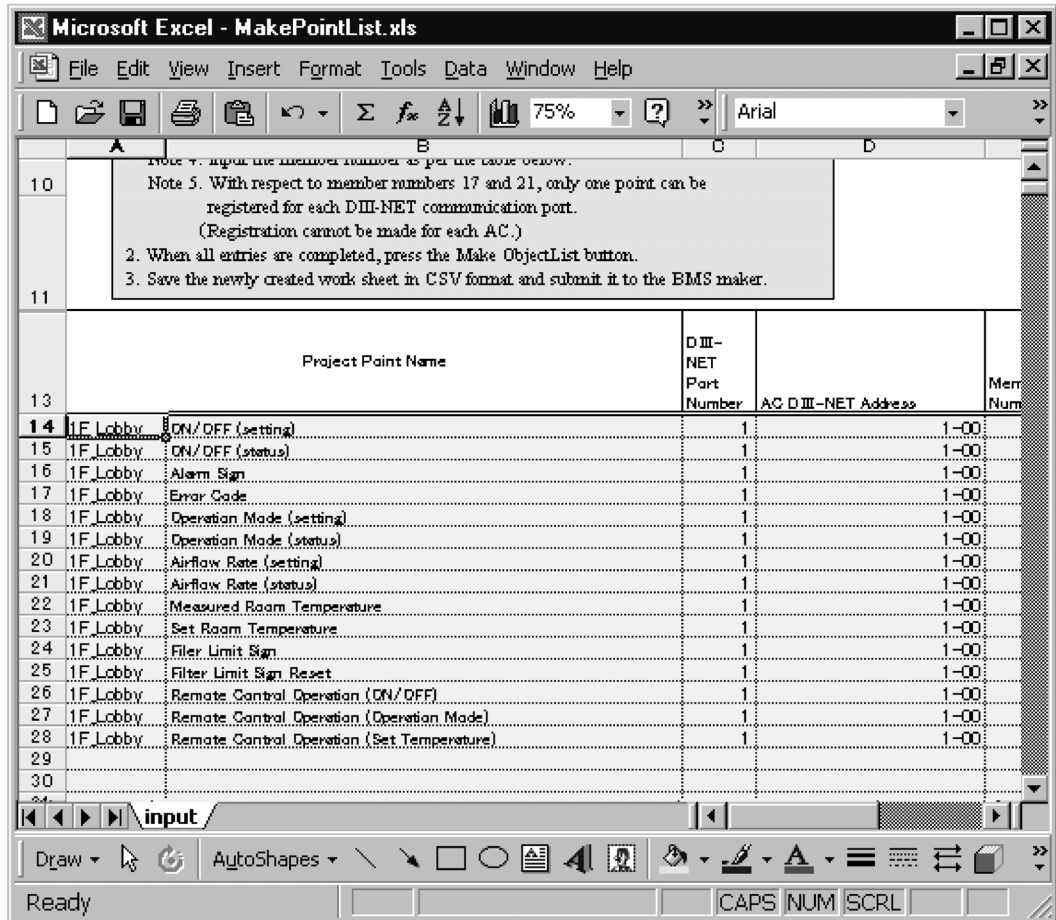

CB03A096C

Screen 2-7. Always enter “1-00” for the “AC D3-NET Address” field for the “Remote Control Operation (Sub Group Address Control Rejection)” used for member number 17 and the “System Forced OFF” used for member number 21, as illustrated in (6) in the figure below. Enter 1 line for each D3-NET port for member numbers 17 and 21.

	A	B	C	D	
	Project Point Name		D3-NET Port Number	AC D3-NET Address	Mem Num
13					
14	1F_Lobby	DN/ DFF (setting)	1	1-00	
15	1F_Lobby	DN/ DFF (status)	1	1-00	
16	1F_Lobby	Alarm Sign	1	1-00	
17	1F_Lobby	Error Code	1	1-00	
18	1F_Lobby	Operation Mode (setting)	1	1-00	
19	1F_Lobby	Operation Mode (status)	1	1-00	
20	1F_Lobby	Airflow Rate (setting)	1	1-00	
21	1F_Lobby	Airflow Rate (status)	1	1-00	
22	1F_Lobby	Measured Room Temperature	1	1-00	
23	1F_Lobby	Set Room Temperature	1	1-00	
24	1F_Lobby	Filter Limit Sign	1	1-00	
25	1F_Lobby	Filter Limit Sign Reset	1	1-00	
26	1F_Lobby	Remote Control Operation (DN/ DFF)	1	1-00	
27	1F_Lobby	Remote Control Operation (Operation Mode)	1	1-00	
28	1F_Lobby	Remote Control Operation (set temperature)	1	1-00	
29	D3Port_1	System Forced OFF	1	1-00	
30					
31					
32					
33					

3

CB03A096C

Screen 2-8. The screen will appear as illustrated below once all objects used in the P3 example have been entered.

	A	B	C	D	E
		Project Point Name	DIII-NET Part Number	AG DIII-NET Address	Member Number
13					
14	1F.Lobby	DN/ DFF (setting)	1		1-00
15	1F.Lobby	DN/ DFF (status)	1		1-00
16	1F.Lobby	Alarm_Sign	1		1-00
17	1F.Lobby	Error Code	1		1-00
18	1F.Lobby	Operation Made (setting)	1		1-00
19	1F.Lobby	Operation Made (status)	1		1-00
20	1F.Lobby	Airflow Rate (setting)	1		1-00
21	1F.Lobby	Airflow Rate (status)	1		1-00
22	1F.Lobby	Measured Room Temperature	1		1-00
23	1F.Lobby	Set Room Temperature	1		1-00
24	1F.Lobby	Filter Limit Sign	1		1-00
25	1F.Lobby	Filter Limit Sign Reset	1		1-00
26	1F.Lobby	Remate Control Operation (DN/ DFF)	1		1-00
27	1F.Lobby	Remate Control Operation (Operation Made)	1		1-00
28	1F.Lobby	Remate Control Operation (Set Temperature)	1		1-00
29	D3Port.1	System Forced DFF	1		1-00
30	4F.Tenant2	DN/ DFF (setting)	4		4-15
31	4F.Tenant2	DN/ DFF (status)	4		4-15
32	4F.Tenant2	Alarm_Sign	4		4-15
33	4F.Tenant2	Error Code	4		4-15
34	4F.Tenant2	Operation Made (setting)	4		4-15
35	4F.Tenant2	Operation Made (status)	4		4-15
36	4F.Tenant2	Airflow Rate (setting)	4		4-15
37	4F.Tenant2	Airflow Rate (status)	4		4-15
38	4F.Tenant2	Measured Room Temperature	4		4-15
39	4F.Tenant2	Set Room Temperature	4		4-15
40	4F.Tenant2	Filter Limit Sign	4		4-15
41	4F.Tenant2	Filter Limit Sign Reset	4		4-15
42	4F.Tenant2	Remate Control Operation (DN/ DFF)	4		4-15
43	4F.Tenant2	Remate Control Operation (Operation Made)	4		4-15
44	4F.Tenant2	Remate Control Operation (Set Temperature)	4		4-15
45	D3Port.2	System Forced DFF	4		1-00
46					
47					
48					
49					
50					
51					
52					
53					
54					

CB03A096C

- Click on (1) “Make ObjectList” on Screen 1 once all information has been entered as illustrated on the previous page. The point list shown in Screen 2 below will be displayed.

Screen 1. Screen after all input is complete

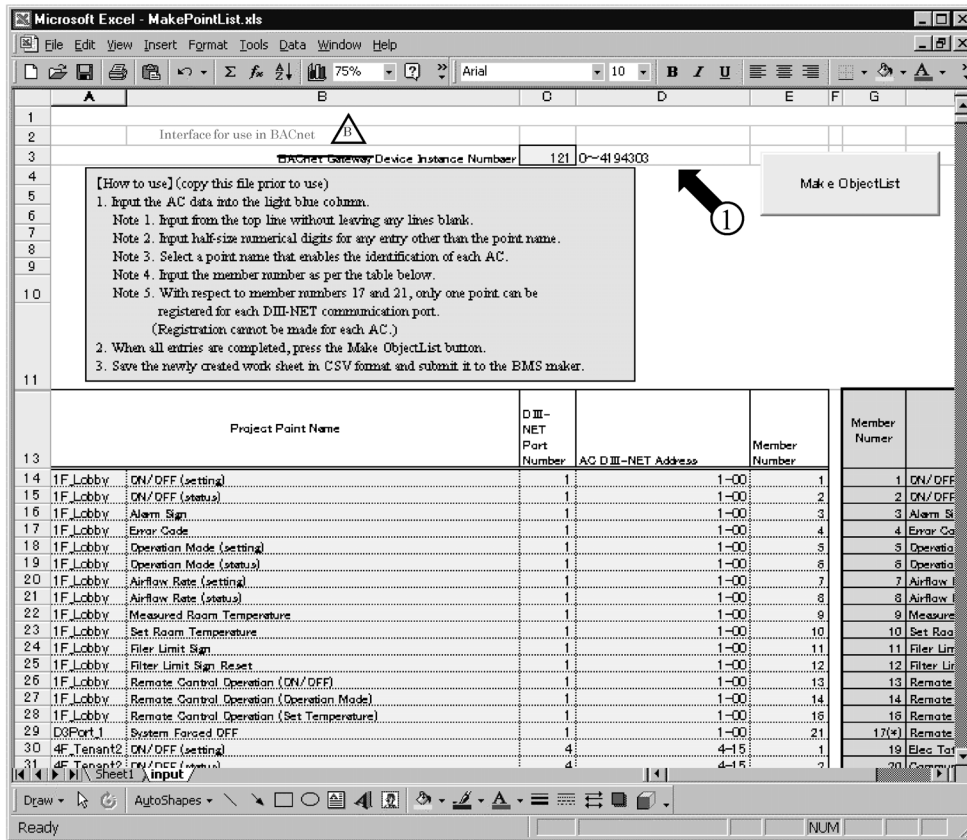

- Use the following procedure to copy the point list and create and save a new CSV-format file.
 - Click on (2) in the upper left corner of screen 2 to select all the cells in the sheet.
 - Next, click on (3) “Edit” and select “Copy” from the pull-down menu to copy the selected cells.
 - Click on (4) “File” and select “New...” from the pull-down menu to create a new file like the one shown in Screen 3.
 - Paste the data copied in step 4-2 into the newly created file.
 - Click on (5) to specify where the data is to be pasted. Next click on (6) “Edit” and select “Paste” from the pull-down menu to paste the copied data. Screen 1 on the following page shows the screen with the pasted data.

Screen 2. Screen Point List

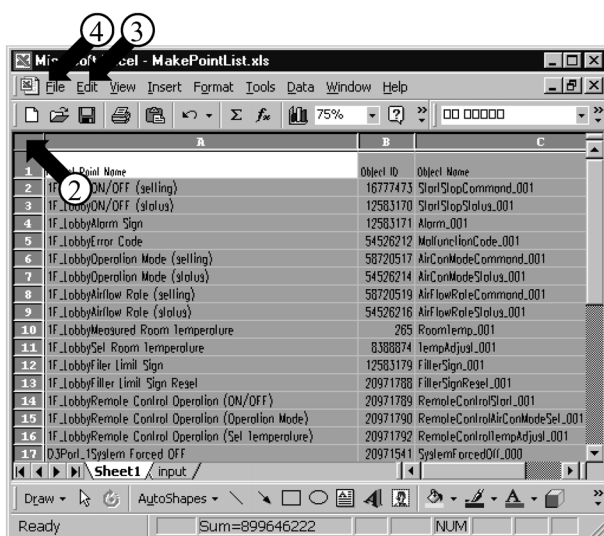

Screen 3. Screen New file

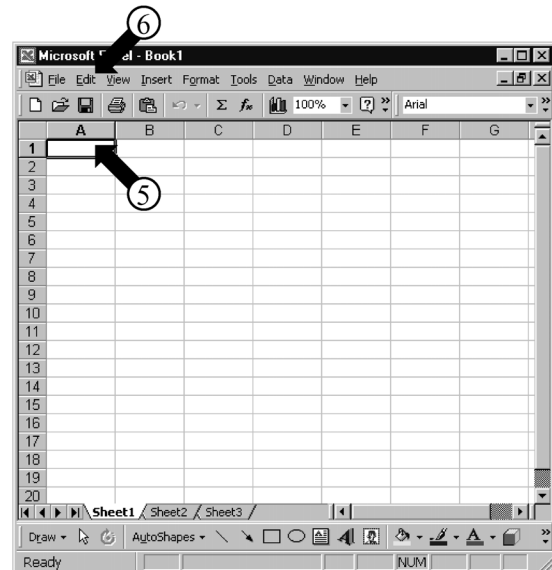

- 5. Assign a name to the file created on the previous page and save it.
- 5-1. Screen 1 shows the screen resulting from following the steps on the previous page.
 - ①Click on (1) “File” and select “Save As”from the pull-down menu to display the “Save As” dialog shown in Screen 2.
 - 5-2. ②Select on “CSV(Comma delimited)(*.csv)” from the (2) pull-down menu.
 - 5-3. ③Enter a filename in (3). (Use a unique name that will not be easily mistaken.)
 - 5-4. Finally, click on (4) “Save” to save the file.
- 6. Send the file saved in step 5-4 to the central control board maker electronically to complete the point list creation procedure.
(Store this point list. Do not discard this data, as it may be required for future use, as when adding AC units.)

Screen 1. Newly created file after data has been copied

Project Point Name	Object ID	Object Name	Object Type	Instance Number
1F_LobbyON/OFF (setting)	16777473	StartStopCommand_001	4	257
1F_LobbyON/OFF (status)	12583170	StartStopStatus_001	3	258
1F_LobbyAlarm Sign	12583171	Alarm_001	3	259
1F_LobbyError Code	54526212	MalfunctionCode_001	13	260
1F_LobbyOperation Mode (setting)	58720517	AirConModeCommand_001	14	261
1F_LobbyOperation Mode (status)	54526214	AirConModeStatus_001	13	262
1F_LobbyAirflow Rate (setting)	58720519	AirFlowRateCommand_001	14	263
1F_LobbyAirflow Rate (status)	54526216	AirFlowRateStatus_001	13	264
1F_LobbyMeasured Room Temperature	265	RoomTemp_001	0	265
1F_LobbySet Room Temperature	8388874	TempAdjust_001	2	266
1F_LobbyFilter Limit Sign	12583179	FilterSign_001	3	267
1F_LobbyFilter Limit Sign Reset	20971788	FilterSignReset_001	5	268
1F_LobbyRemote Control Operation (ON/OFF)	20971789	RemoteControlStart_001	5	269
1F_LobbyRemote Control Operation (Operation Mode)	20971790	RemoteControlAirConModeSet_001	5	270
1F_LobbyRemote Control Operation (Set Temperature)	20971792	RemoteControlTempAdjust_001	5	272
D3Port_1System Forced OFF	20971541	SystemForcedOff_000	5	21
4F_Tenant2ON/OFF (setting)	16842497	StartStopCommand_255	4	65281
4F_Tenant2ON/OFF (status)	12648194	StartStopStatus_255	3	65282
4F_Tenant2Alarm Sign	12648195	Alarm_255	3	65283
4F_Tenant2Error Code	54591236	MalfunctionCode_255	13	65284
4F_Tenant2Operation Mode (setting)	58785541	AirConModeCommand_255	14	65285
4F_Tenant2Operation Mode (status)	54591238	AirConModeStatus_255	13	65286
4F_Tenant2Airflow Rate (setting)	58785543	AirFlowRateCommand_255	14	65287
4F_Tenant2Airflow Rate (status)	54591240	AirFlowRateStatus_255	13	65288
4F_Tenant2Measured Room Temperature	65289	RoomTemp_255	0	65289

Screen 2. Screen Save As

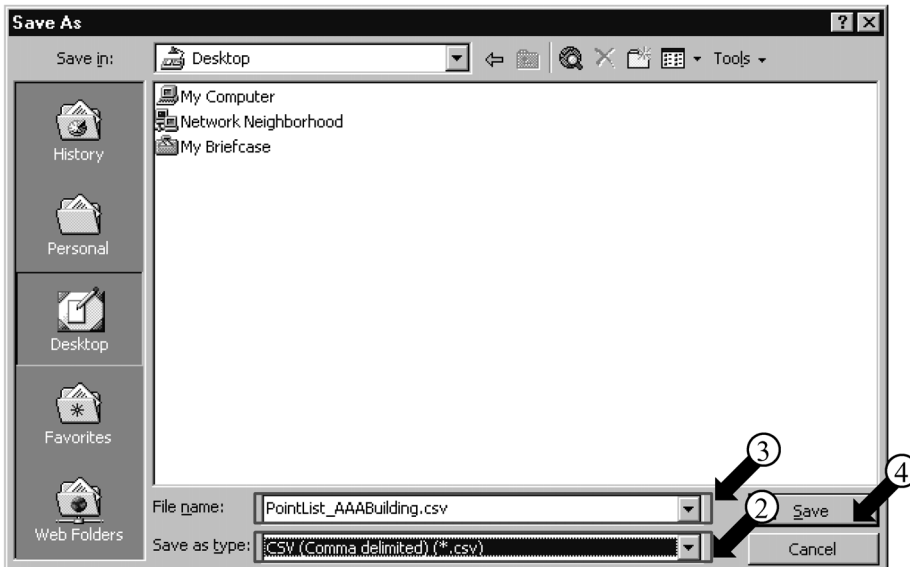

Part 4

Daikin's Agreement

1. Daikin's Interface for use in BACnet[®] Agreement.....96

1. Daikin's Interface for use in BACnet® Agreement

1. **JMT** — (Joint Matching Test) This is necessary for every independent BMS.
The case where a JMT is not necessary is where previously a successful JMT has been carried out and the BMS system has not been updated by software or hardware changes. In the case that the BMS has updated their system by either changes, a following JMT will be required.
2. **D-BACS setup-tool** — Use of Daikin's D-BACS setup-tool is for confirming the operation / state of connected A / C units & address ID's, prior to connection with the BMS system.
3. **BMS Engineering** — Creating of the Points. This is NOT to be done by Daikin since it is directly related to the BMS side. The BMS engineer is to carry out the engineering of the Point, however Daikin is responsible for providing the method of how the points are calculated.
4. **Commission** — First step, only using Daikin's Interface for use in BACnet®, without connecting BMS. This is to be carried out by Daikin engineering staff with the use of the D-BACS set up tool.
5. **Discrepancy of operation of gateway by BMS** — In the case that the BMS maker feels that the Interface for use in BACnet® is not functioning correctly via the BACnet® Protocol, a test with the use of Daikin's BACnet® Client software can confirm this. (This test is generally not required.)

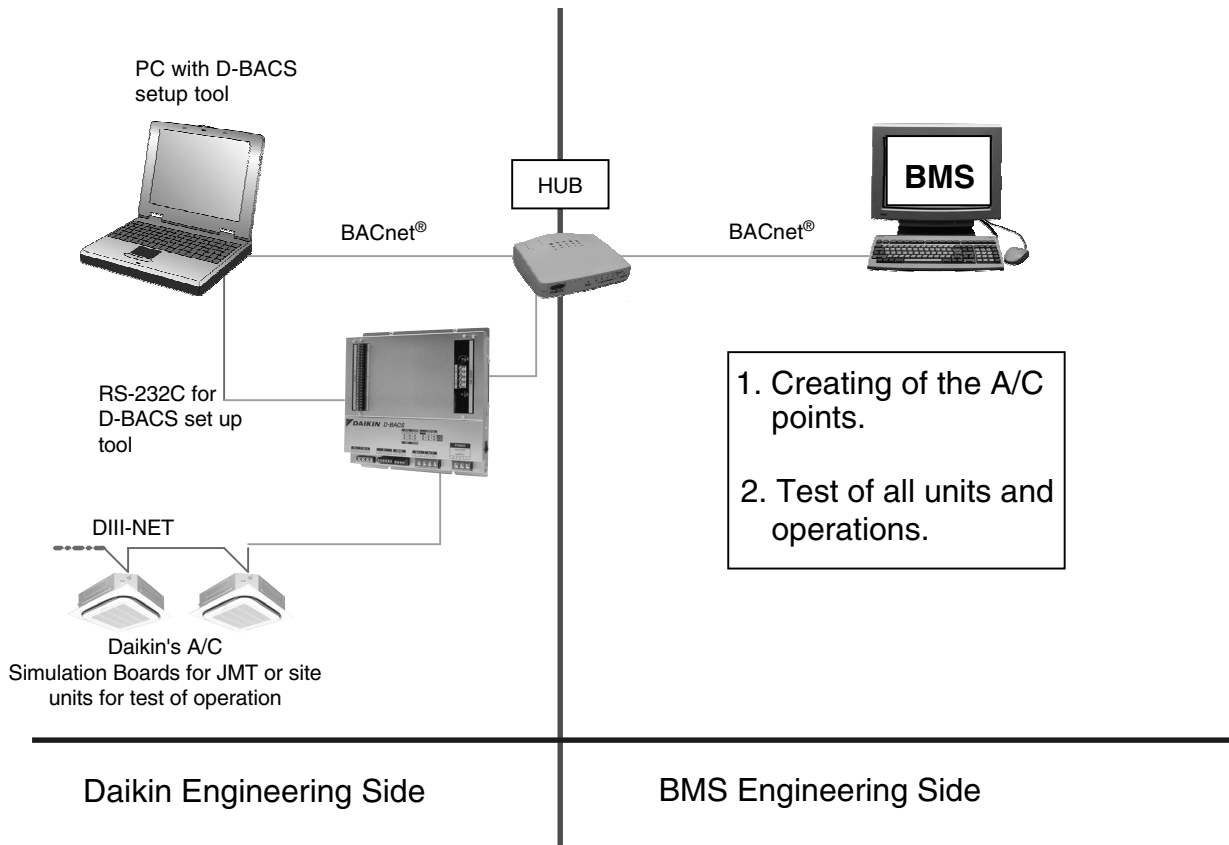

Part 5

Test Operation Manual

1. BACnet [®] Object System Diagram of Interface for use in BACnet [®]	98
2. Specifications of Interface for use in BACnet [®] (1)	99
3. Specifications of Interface for use in BACnet [®] (2)	100
4. Before Visiting the Site	101
4.1 Check the Specifications of the PC and Communication Cable Used for the Trial Operation as well as the Version of the Trial Operation Program.....	101
4.2 Obtaining Object Information.....	102
4.3 Setting the Trial Operation PC Modem (When Connecting the Interface for use in BACnet [®] and the Trial Operation PC Using RS232C Communication).....	105
5. Work Procedure for the Interface for use in BACnet [®]	115
5.1 Connect the Trial Operation PC and Interface for use in BACnet [®] Via the RS232C Cross Cable or the Hub Using the 100BASE-TX Straight Cable	116
5.2 Start the Trial Operation Program. (On the Trial Operation PC, Double-click SetupBACnet [®] .) Enter the IP Address	118
5.3 Setting	120
5.4 Reset the Interface for use in BACnet [®]	131
5.5 Start the Trial Operation Program	134
5.6 Select the Operation Status Menu and Check the Following	136
5.7 Check the Registration of Management Point Types	137
5.8 Check the All Points from the Central Control Panel.....	138
6. Reference: Items which do not Need to be Changed from the Factory Settings	140
7. Q & A.....	147

1. BACnet® Object System Diagram of Interface for use in BACnet®

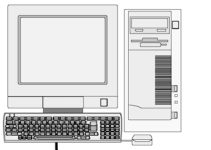

Central control panel

[Function Overview of Interface for use in BACnet]
 ● Communication interface between the central control panel and air conditioners.
 • You can connect the central control panel and air conditioners via BACnet (Note 1) which is an open network.
 • You can send operation status from each air conditioner to the central control panel and start/stop each air conditioner from the central control panel.
 Note 1: A communication protocol supported by the IPv4 standard.
 : BACnet/IP

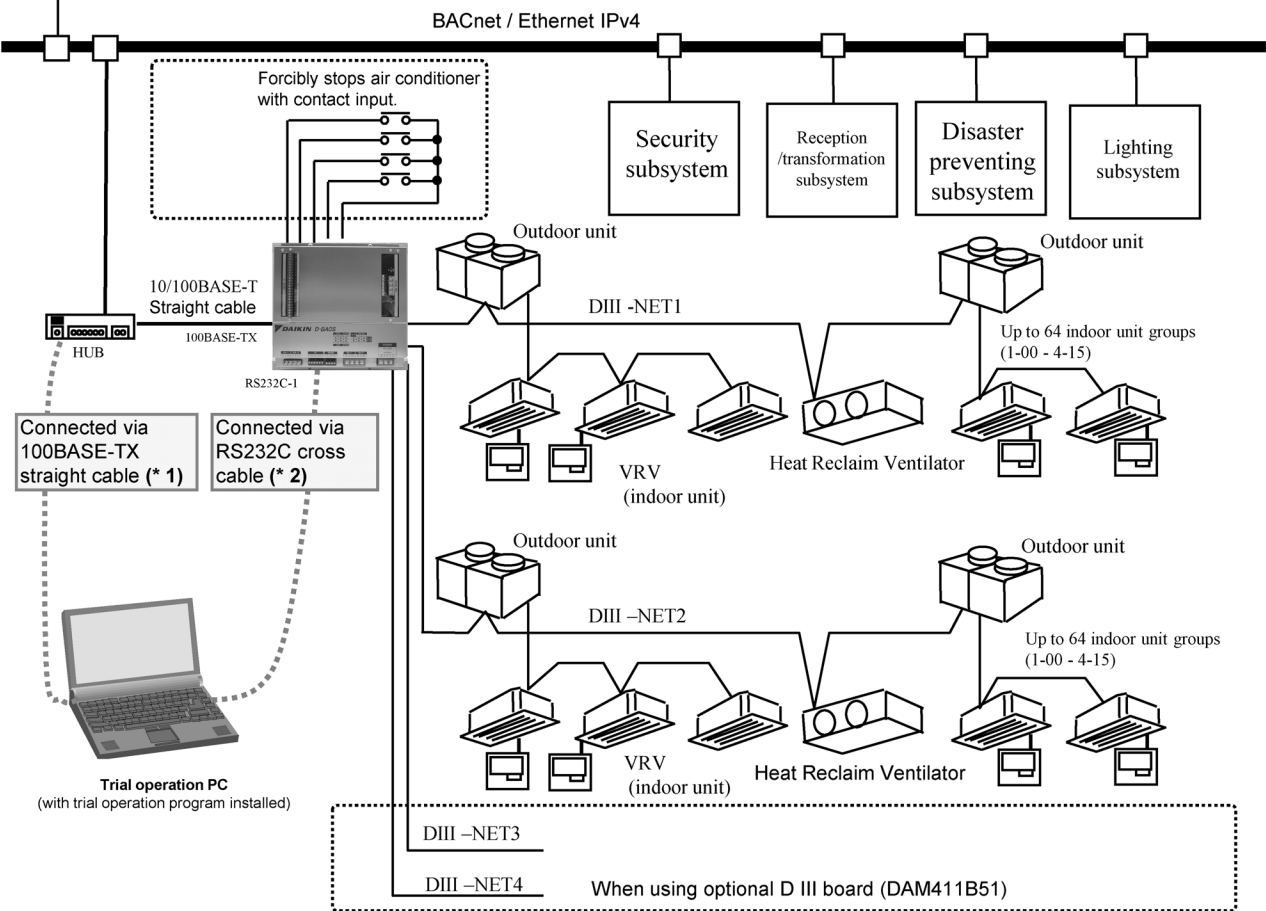

(You can connect the trial operation PC in one of the two ways. You can use either method.): Refer to P.23 for the details.

* 1: The following conditions must be satisfied when using the 100BASE-TX straight cable:

- The 100BASE-TX straight cable (LAN straight cable) should be used. (This type of cable is sold at a common electrical store.)
- One free port should be reserved with the hub (procured locally) shown above. Also, an IP address which can be temporarily used at the on-site test operation should be provided (ask the sales division or site).
- When only configuring the Interface for use in BACnet, you can connect the 100BASE-TX cross cable (LAN cross cable) directly to the Interface for use in BACnet, rather than connecting the straight cable to the hub.
- You should be able to change the IP address of the trial operation PC and return to the original address after the test (refer to P.25 for the procedure).

*: Using the 100BASE-TX straight cable for the trial operation ensures faster communication than using RS232C and allows quicker settings.

*2: When connecting the trial operation PC to the Interface for use in BACnet using the RS232C cross cable, you must configure the dial-up adapter and modem in advance. Refer to P.12 through P.21 for the procedure.

2. Specifications of Interface for use in BACnet® (1)

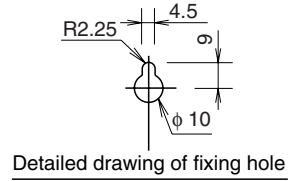
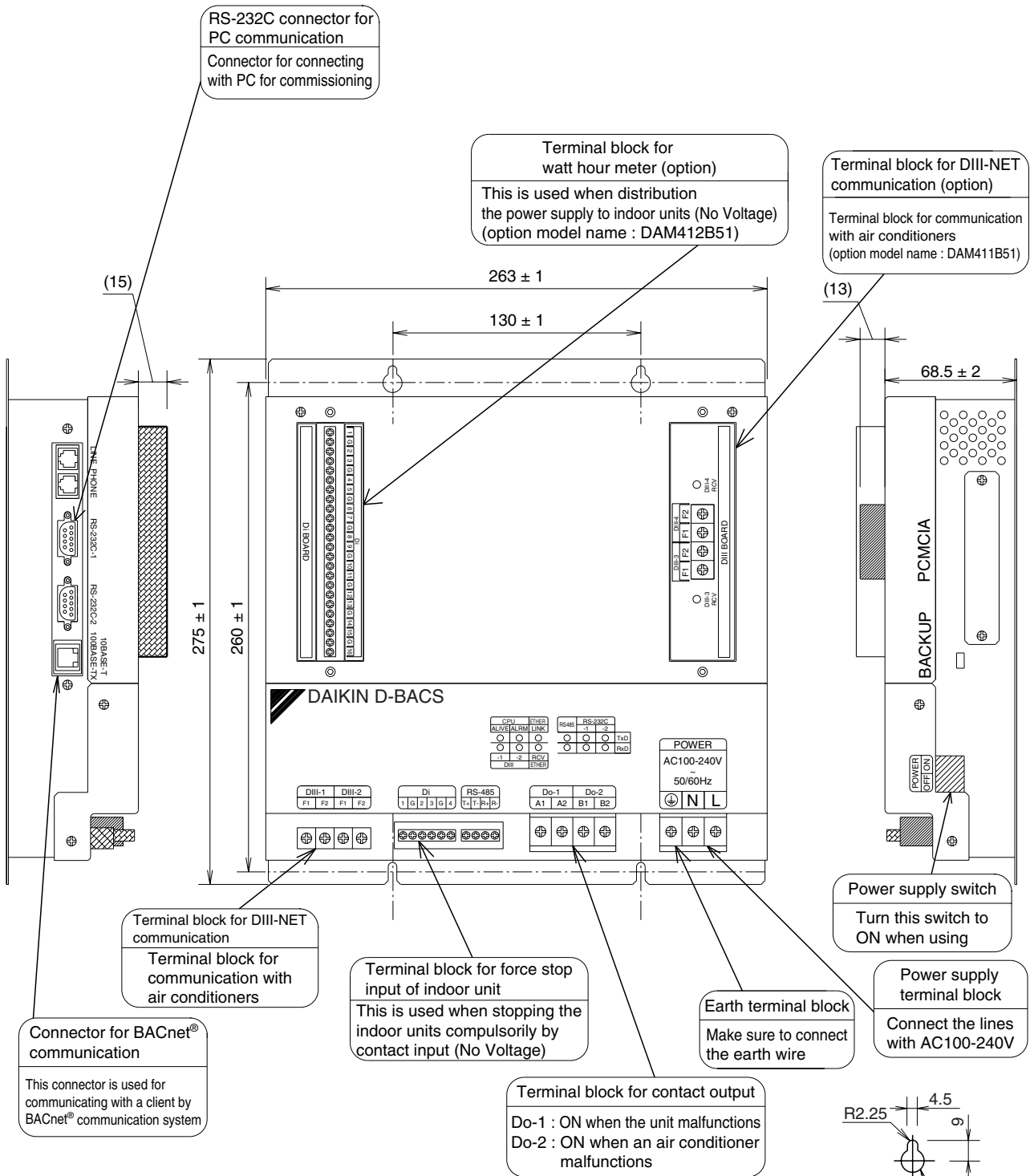

CB06A069E

3. Specifications of Interface for use in BACnet® (2)

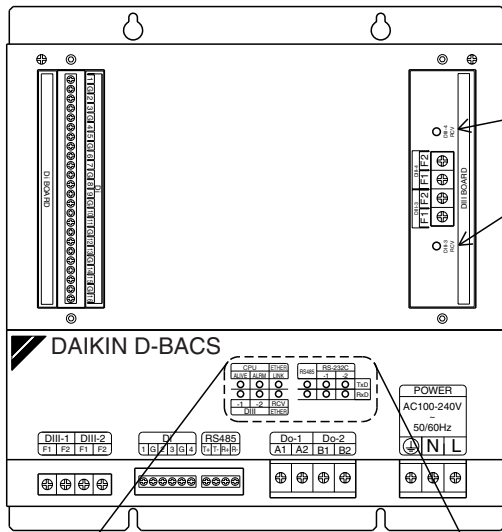

LED display

DIII-4 RCV	It flashes when it receives/transmits data from/to the equipment connected with DIII-4 such as air conditioners
DIII-3 RCV	It flashes when it receives/transmits data from/to the equipment connected with DIII-3 such as air conditioners

LED display

CPU ALIVE	It flashes when the unit is normal operation.
CPU ALARM	It flashes when the unit is abnormal operation.
DIII-1	It flashes when it receives/transmits data from/to the equipment connected with DIII-1 such as air conditioners
DIII-2	It flashes when it receives/transmits data from/to the equipment connected with DIII-2 such as air conditioners
Ether RCV	It flashes when it receives/transmits data from/to BACnet® client
Ether Link	It lights when the 10BASE-T cable or 100BASE-TX cable
RS-485 (Tx/D)	This LED display cannot be used with this unit
RS-485 (Rx/D)	This LED display cannot be used with this unit
RS-232C-1 (Tx/D)	It flashes when it transmits data to PC
RS-232C-1 (Rx/D)	It flashes when it receives data to PC
RS-232C-2 (Tx/D)	This LED display cannot be used with this unit.
RS-232C-2 (Rx/D)	This LED display cannot be used with this unit.

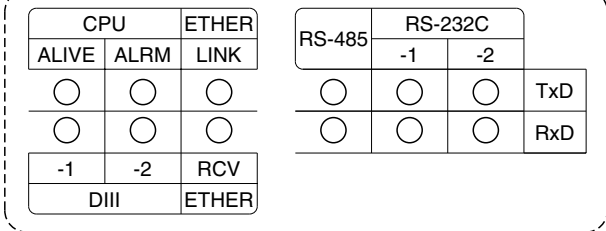

- 1) Electrical rating
 - (1) Rated voltage: Single-phase 100 - 240 VAC 50/60 Hz
 - (2) Power consumption: Max. 20 W
- 2) Environmental conditions
 - (1) Power supply voltage variation: ± 10% of the rated value
 - (2) Operating temperature: -10 - 50 °C
 - (3) Operating humidity: 0 - 90 % (no dewing)
 - (4) Storage temperature: -20 - 60 °C
- 3) Performance - Insulation resistance: 50 MΩ or higher at DC500 V mega
- 4) Weight: 3.0 kg
- 5) Surface: Stainless hairline finish

- 6) Contact I/O
 - Do-1: ON when Interface for use in BACnet is malfunctioning
 - Do-2: ON when the connected air conditioner is malfunctioning
 - Di-1 - 4: Air conditioner forced stop contact input for each D III-NET communication port
 - OPDi-1 - 12: Power pulse input for proportional power distribution among air conditioners
 - OPDi-13 - 16: Not used

CB06A069E

4. Before Visiting the Site

4.1 Check the Specifications of the PC and Communication Cable Used for the Trial Operation as well as the Version of the Trial Operation Program

1-1. PC specifications

- OS : Windows XP SP3
- Communication port necessary on PC : PC's RS232C communication port: 1 port
(Since the trial operation may not be performed properly if you convert a USB port into the RS232C communication port, be sure to prepare a PC with an RS232C communication port.)
- : Ethernet (for LAN communication): 1 port

1-2. Communication cable specifications required for trial operation (communication cable to connect the Interface for use in BACnet and trial operation PC) RS232C communication cable : Cross cable with 9 pin (female) - 9 pin (female)

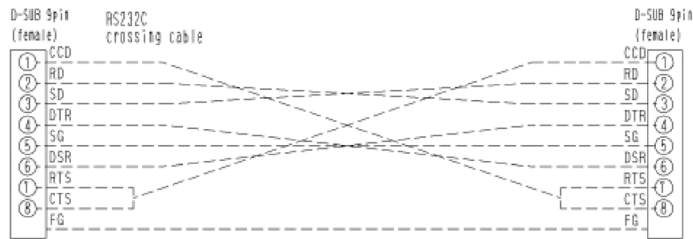

- Ethernet (100BASE-TX) cable: LAN cable (straight cable)
- Ethernet (100BASE-TX) cable: LAN cable (cross cable)
(Used when there is no hub at the site or the hub is faulty.)

1-3. Checking the version of the trial operation program installed on the PC

The trial operation program version 6.3.4.0 or higher is required for trial operation of the Interface for use in BACnet (DMS502B51).
 Check the version of the trial operation program installed on the PC before visiting the site in the following procedure.
(How to check the trial operation program version)
 Right-click the trial operation program of Interface for use in BACnet [1] (program name: SetupBACnet), and choose "Property (R)".
 Click the "Version" tab [2] and confirm that the version number shown in the "File Version" field [3] is 6.3.4.0 or higher.
 Any trial operation programs with lower version than the version shown above cannot configure Interface for use in BACnet which is in conformity with BTL. Obtain Version 6.3.4.0 or higher and install it on the PC before the trial operation.

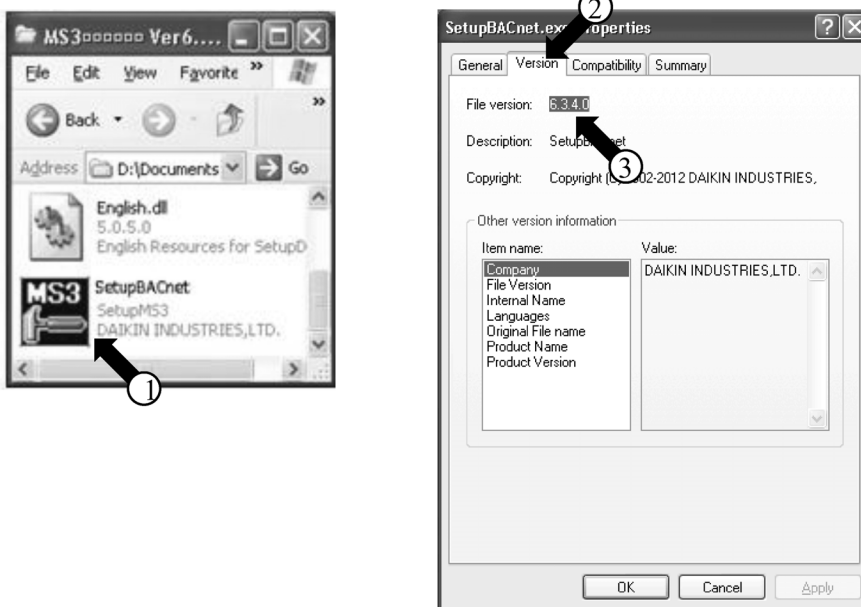

4.2 Obtaining Object Information

You must initialize the Interface for use in BACnet® before the trial operation. Therefore, you need to **gather the object information listed below ([1] - [6])** before visiting the site. Obtain this information from **the sales person of Daikin or distributor for the object.**

(Fill in the information proprietary to the object in the blank space of [1] - [6].)

[1] Confirmation of communication method between the Interface for use in BACnet® and the central control panel

Communication method between the Interface for use in BACnet and the central control panel

No.	Communication method	Communication method for the object (circle one of them)
1	BACnet/IP communication	

[2] BACnet communication port number

*: The factory setting is 47808. The available setting range is 1 - 65535.

BACnet communication port number	
----------------------------------	--

[3] Instance number for the Interface for use in BACnet

*: The available setting range is 0 - 4194302 and the factory setting is 0.

Device instance number of Interface for use in BACnet	
--	--

[4] Working drawings

- Cable routing diagram (which provides the following information)
 - The number and locations of the Interface for use in BACnet
 - The number and locations of the optional D III boards
 - The number and locations of the optional Di boards
 - Material (e.g., drawing) which shows the number of air conditioners and mapping between the addresses and locations of air conditioners

CB06A069E

[5] Items monitored/controlled from the central control panel for air conditioners

Member number (for BACnet)	Monitor/control item	Object type (for BACnet)	Monitor/control from the central control panel for each air conditioner (yes/no)
1	ON/OFF (setting)	BO	
2	ON/OFF (status)	BI	
3	Alarm Sign	BI	
4	Error Code	MI	
5	Operation Mode (setting)	MO	
6	Operation Mode (status)	MI	
7	Airflow Rate (setting)	MO	
8	Airflow Rate (status)	MI	
9	Measured Room Temperature	AI	
10	Set Room Temperature	AV	
11	Filter Limit Sign	BI	
12	Filter Limit Sign Reset	BV	
13	Remote Control Operation (ON/OFF)	BV	
14	Remote Control Operation (Operation Mode)	BV	
16	Remote Control Operation (Set Temperature)	BV	
(*1)17	Remote Control Operation (Sub Group Address Control Rejection)	BV	
(*2)18	Accumulated gas	Accumulator	
19	Accumulated power	Accumulator	
20	Communication Status	BI	
(*1)21	System Forced OFF	BV	
22	Air Direction (setting)	AV	
23	Air Direction (status)	AI	
24	Forced Thermostat OFF (setting)	BO	
25	Forced Thermostat OFF (status)	BI	
26	Energy Efficiency Command (setting)	BO	
27	Energy Efficiency Command (status)	BI	
28	Thermostat Status	BI	
29	Compressor Status	BI	
30	Indoor Fan Status	BI	
31	Heater Operation Status	BI	
32	Ventilation mode(setting)	MO	
33	Ventilation mode (status)	MI	
(*3)34	Ventilation amount (setting)	MO	
(*3)35	Ventilation amount (status)	MI	

*1: Instructed per D III-NET communication port.

*2 : Member number 18 is for Japanese market only.

*3 :**The fresh up (Auto) may not be available for monitor/control operation depending on the specifications of the central monitoring panel.**

● Setting BACnet Broadcast

BACnet Broadcast	<u>Local or Global (circle one of them)</u>
------------------	---

[Note]

- BACnet allows two types of broadcasts; global broadcast and local broadcast (Note that they are different from UDP/IP's broadcast). With global broadcast, messages broadcasted are sent beyond the BACnet router to other BACnet networks. With local broadcast, messages broadcasted are not sent beyond the BACnet router but only reach nodes within the same BACnet network. (Details of the global broadcast and local broadcast are described in Section 6.3.2 of the ANSI/ASHRAE Standard 135-2004.)
- If a slow BACnet network (e.g., BACnet connected via RS232C) is connected via the BACnet router to the BACnet/IP network where the station exists, and unregistered COVs which are sent from the station each time an air conditioner changes its status are also propagated over the slower network, these COVs will occupy the communication line of the slower network. Therefore, COVs need to be locally broadcasted in such a network configuration. Note that the Who-Is/I-Am services are globally broadcasted even for BACnet/IP.

CB06A069E

[6] IPv4 address (IP address)

Use a private address as the IP address.

You can set the address and subnet mask to arbitrary values from the PC.

Default: Address = 192.168. 0.1, subnet mask = 255.255.255.0

(Also write another IP address which can be temporarily used for the trial service operation, which will not be used after the trial operation.)

1. IP address for the Interface for use in BACnet

IP address		Ex. 192.168.0.1
Subnet mask		Ex. 255.255.255.0
Default gateway address		Ex. 192.168.0.100

2. IP address temporarily used for the trial service operation (which will not be used after the trial operation)

IP address		Ex. 192.168.0.2
Subnet mask		Ex. 255.255.255.0
Default gateway address		Ex. 192.168.0.100

Restriction on IPv4 address (The following addresses cannot be used.)

One of the following invalid addresses is used as the IP address:

- An address outside the range of the Class A - C addresses (1.0.0.0 - 223.255.255.255)
- A loop-back address (127.0.0.0 - 127.255.255.255)
- An address of which the host portion (hexadecimal "0" portion of subnet mask) contains all "0"s or "1"s
- An address of which the network portion (hexadecimal "1" portion of subnet mask) contains all "0"s or "1"s

[Example]

- 244.1.1.1 -> NG (outside the range of Class A - C addresses)
- 127.0.0.1 -> NG (Loop-back address)
- IP: 198.168.1.0/Subnet: 255.255.255.0 -> NG (host portion contains all "0"s.)
- IP: 192.168.0.1/Subnet: 192.0.0.0 -> NG (network portion contains all "1"s.)

One of the following invalid addresses is used as the default gateway address:

- An address outside the range of the Class A - C addresses (1.0.0.0 - 223.255.255.255)
- A loop-back address (127.0.0.0 - 127.255.255.255)

An invalid address is used for the subnet mask (outside the range 128.0.0.0 - 255.255.255.255, hexadecimal "1" portion contain non-sequential value or blank).

[Example]

- 255.255.255.244 -> NG (hexadecimal "1" portion contain non-sequential value.)

[7] Celsius/Fahrenheit setting

Set the unit for the temperature sent/received to/from the central monitoring panel in BACnet communications to either "Celsius" or "Fahrenheit."

"Celsius" is set as factory default.

Temperature unit in BACnet communication	Select Celsius or Fahrenheit . (put a ring around either of them.)
---	---

4.3 Setting the Trial Operation PC Modem (When Connecting the Interface for use in BACnet® and the Trial Operation PC Using RS232C Communication)

4.3.1 Set Up the Modem

1-1. Open the Control Panel on the PC.

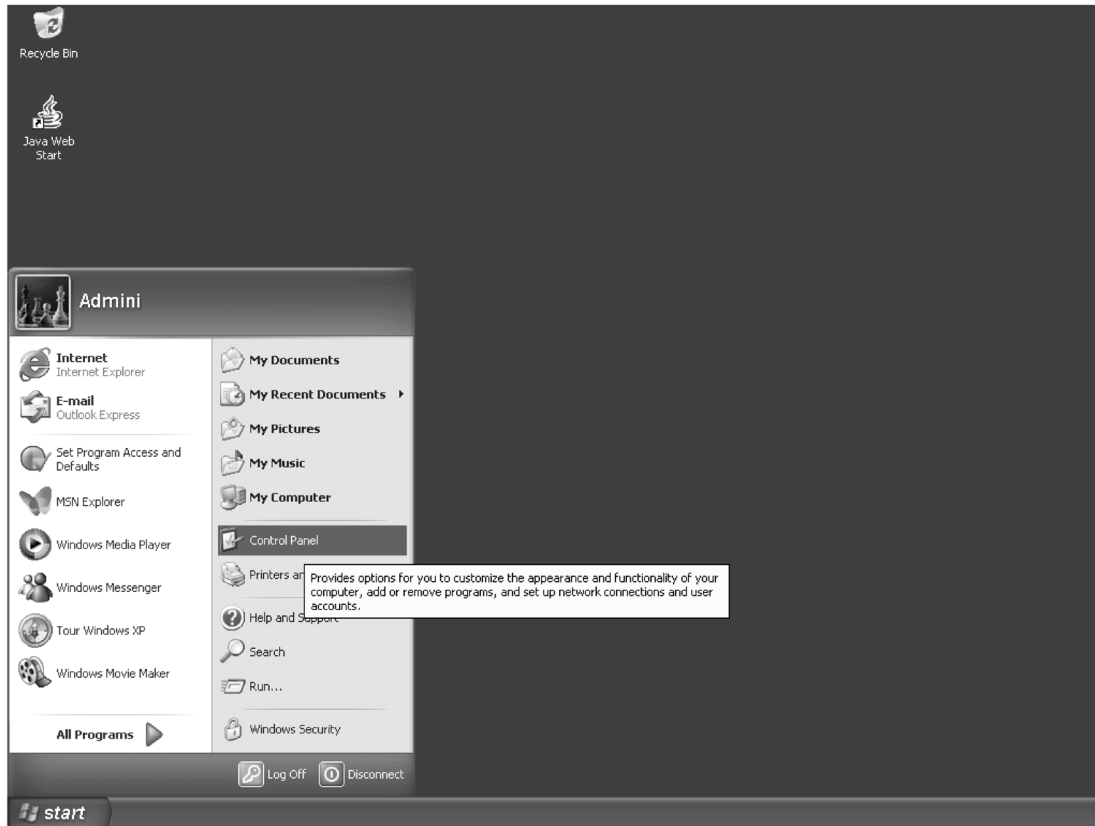

1-2. Double-click "Phone and Modem Options".



CB06A069E

1-3. When the dialog is shown at the below left, enter values as shown and click the OK button. The display changes to the dialog shown at the below right. Click the OK button, and continue to Step 1-4.

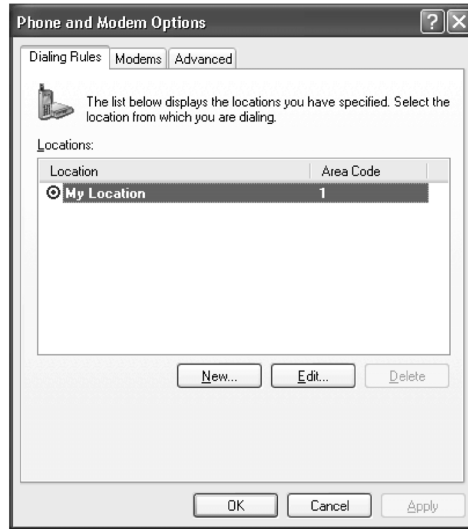

1-4. Click the Add button [1]. The display changes to the dialog shown at the below right. Check the "Don't detect my modem ; I Will select it from a list." option [2] and click the Next button [3].

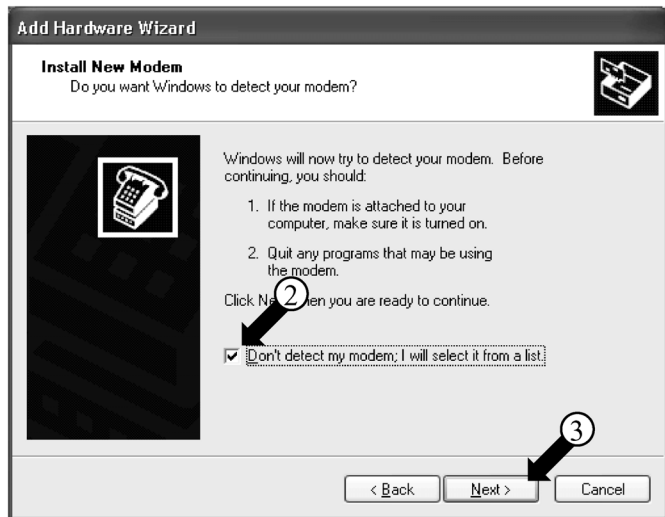

1-5. Click the Have Disk... button [4]. The display changes to the dialog shown on the next page.

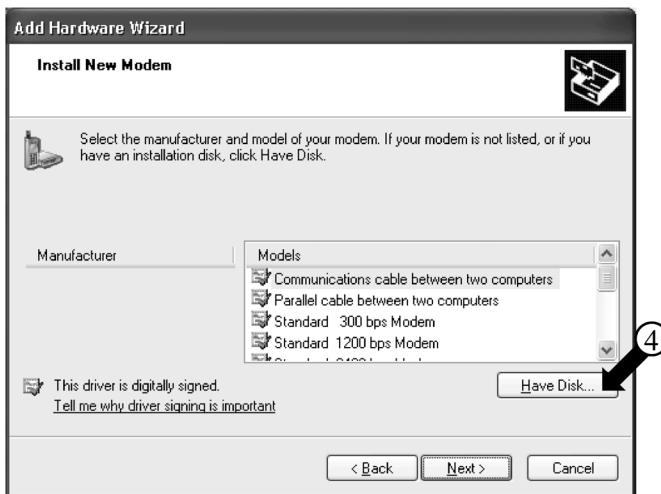

1-6. Click the Browse... button [5] to open the dialog shown in Step 1-7, and specify the GenericNULL modem ver 2.0 folder already copied on the desktop.

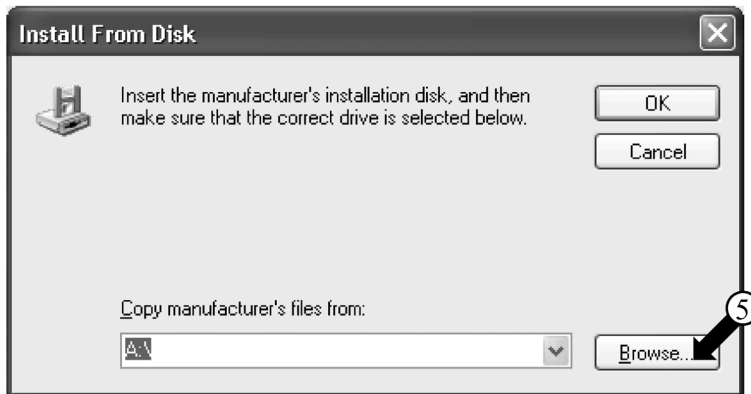

1-7. Select "mdmcisc2" and click the Open button[6].

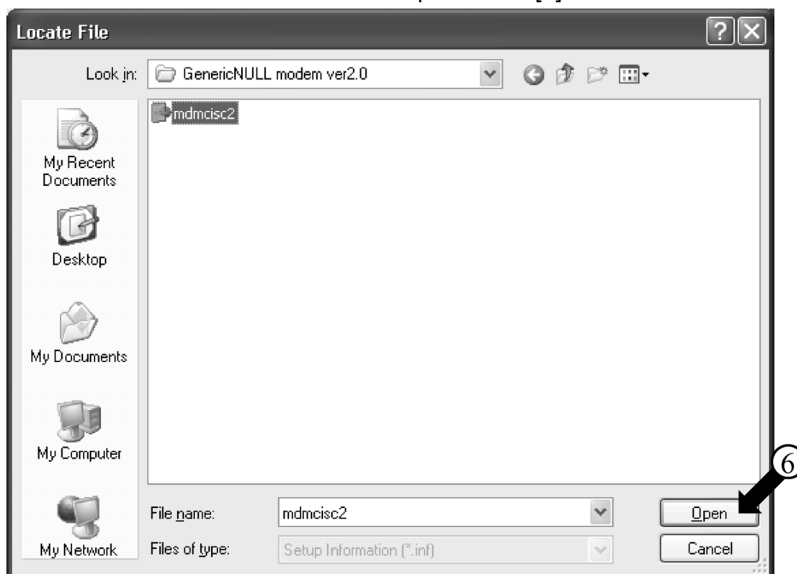

1-8. Click the OK button [7].

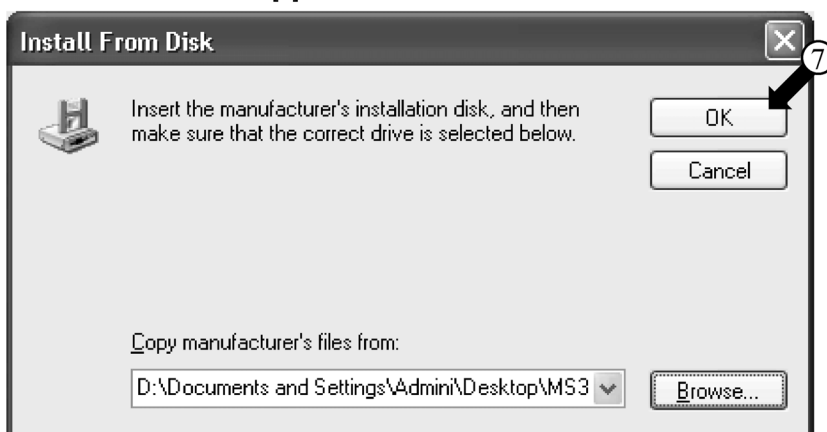

CB06A069E

1-9. Choose "Generic NULL Modem v2" [8] and click the Next > button [9].

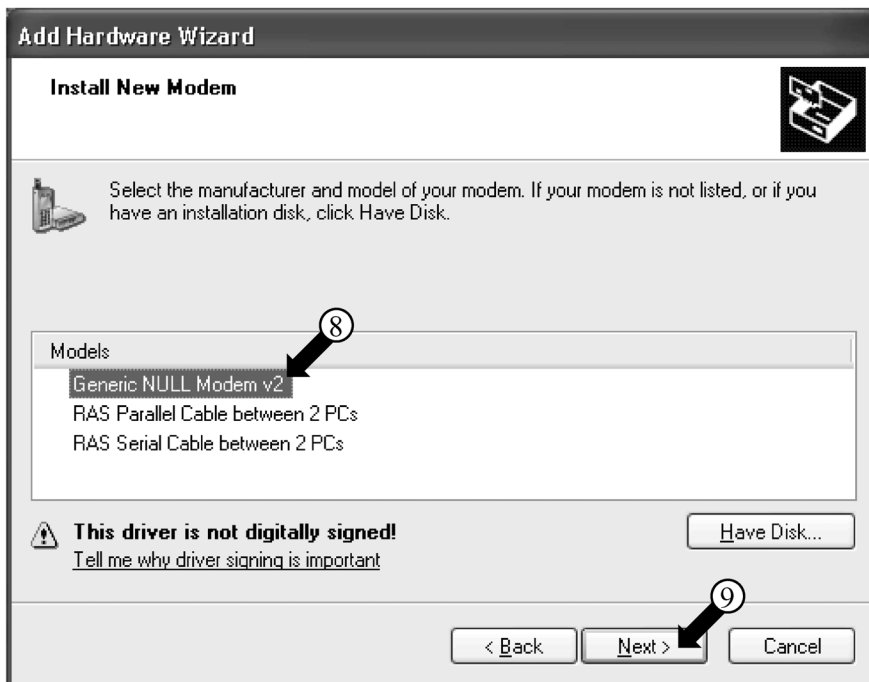

1-10. Choose the COM port [10] to connect the RS232C cable to, and click the Next > button [11].



CB06A069E

1-11. Click the Continue Anyway button [12] because this program will cause no problem.

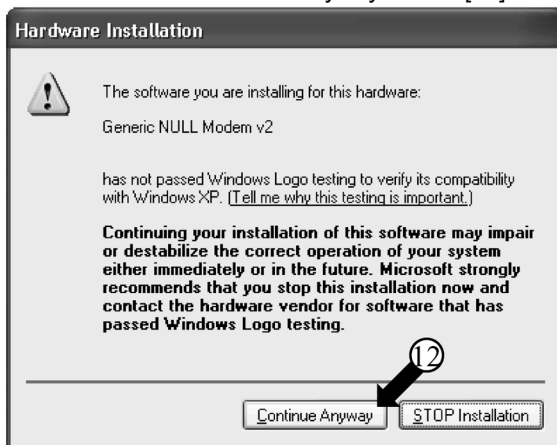

1-12. Click the Finish button [13].



1-13. "Generic NULL Modem v2" is added to [14] and modem set up completes. Next, follow the instructions on the following pages to set up the dial-up adapter.

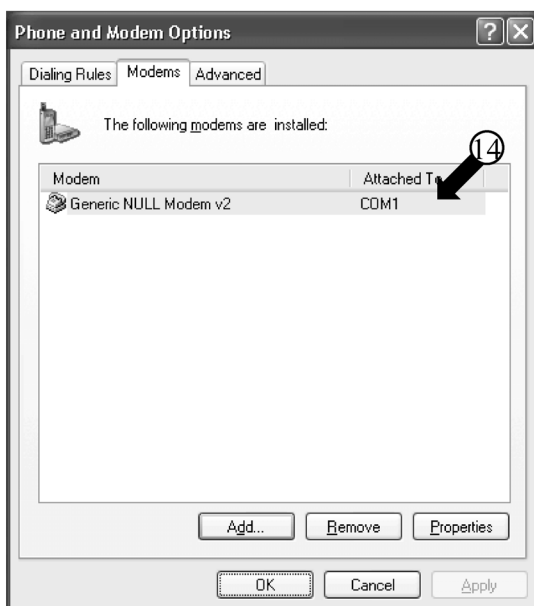

4.3.2 Setting Up the Dial-Up Adaptor

2-1. Open the Control Panel on the PC.

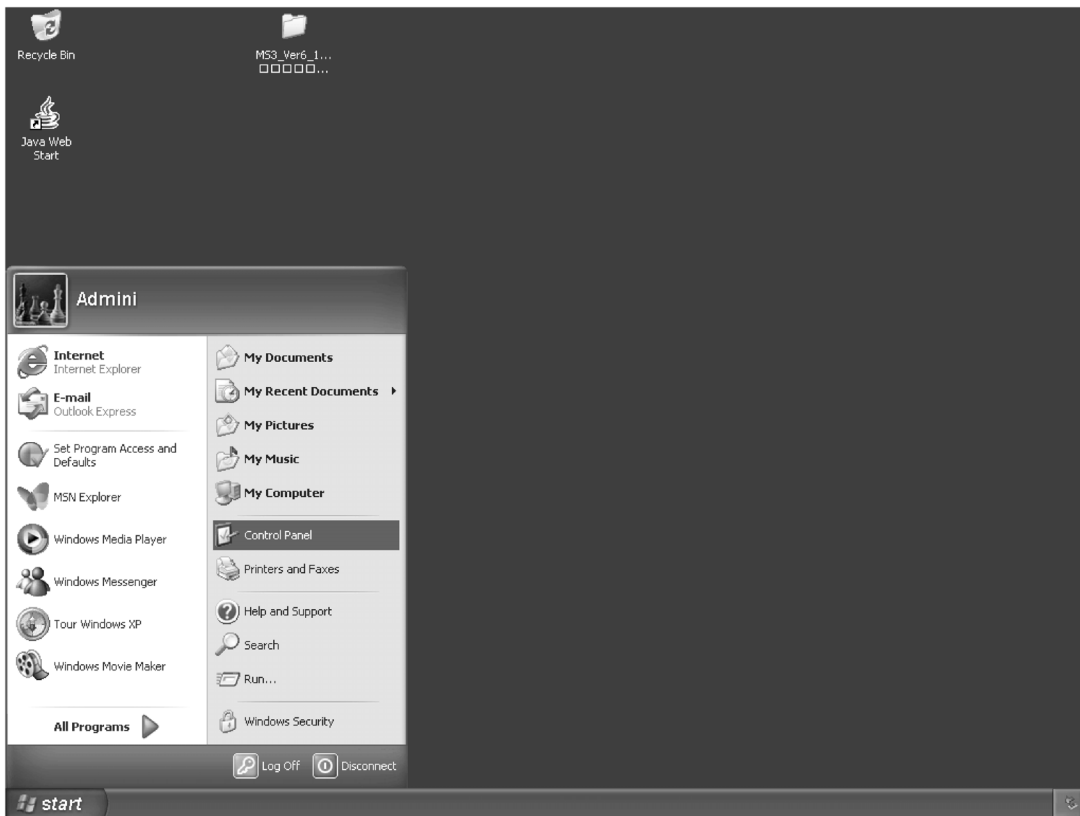

2-2. Double-click the Network Connections icon.



CB06A069E

2-3. The dialog shown below opens. Click "Create a new connection" [1].

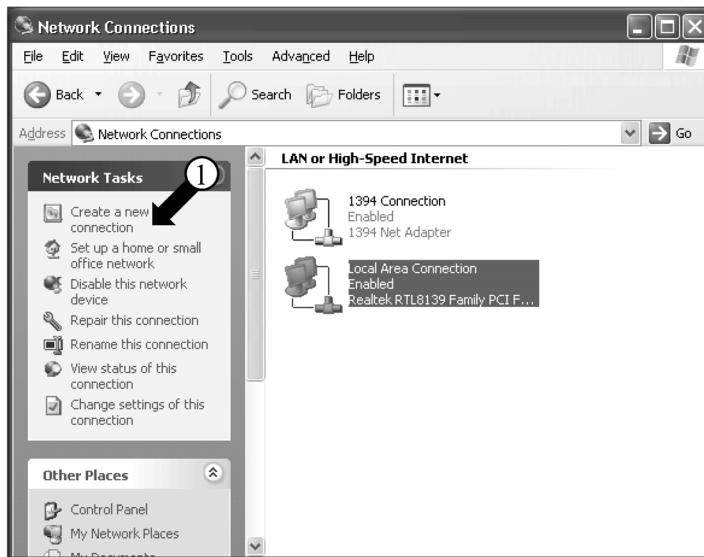

2-4. Click the Next button [2].



2-5. Click "Connect to the network at my workplace" [3].



2-6. Click "Dial-up connection" [4].

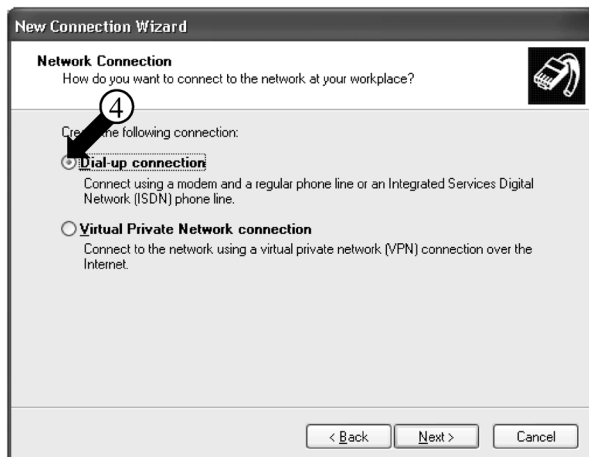

2-7. Enter a name to identify this connection [5]. This example uses "Interface for use in BACnet".



2-8. Enter "1" (one) in the Phone number field [6].

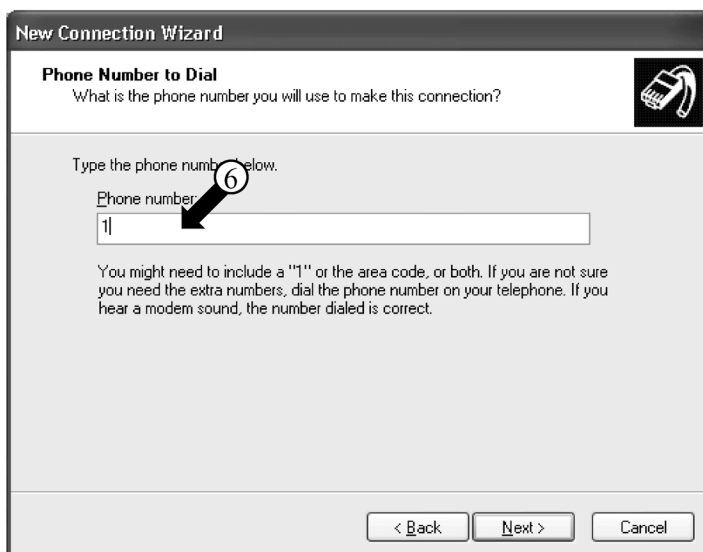

CB06A069E

2-9. Check the option [7] and click the Finish button [8].



2-10. When the dialog shown below opens, click the Properties button [9].



2-11. If multiple choices are shown in [10], select "Generic NULL Modem v2". Then click the Configure button [11].



2-12. Choose "38400" [12] and click the OK button [13]. This completes the setup procedure.

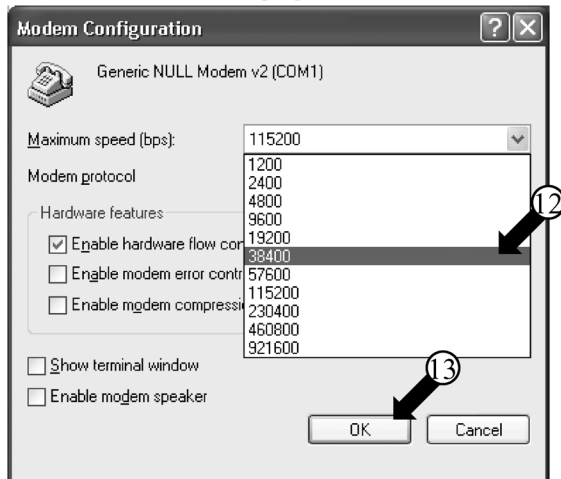

CB06A069E

5. Work Procedure for the Interface for use in BACnet®

Trial operation flow

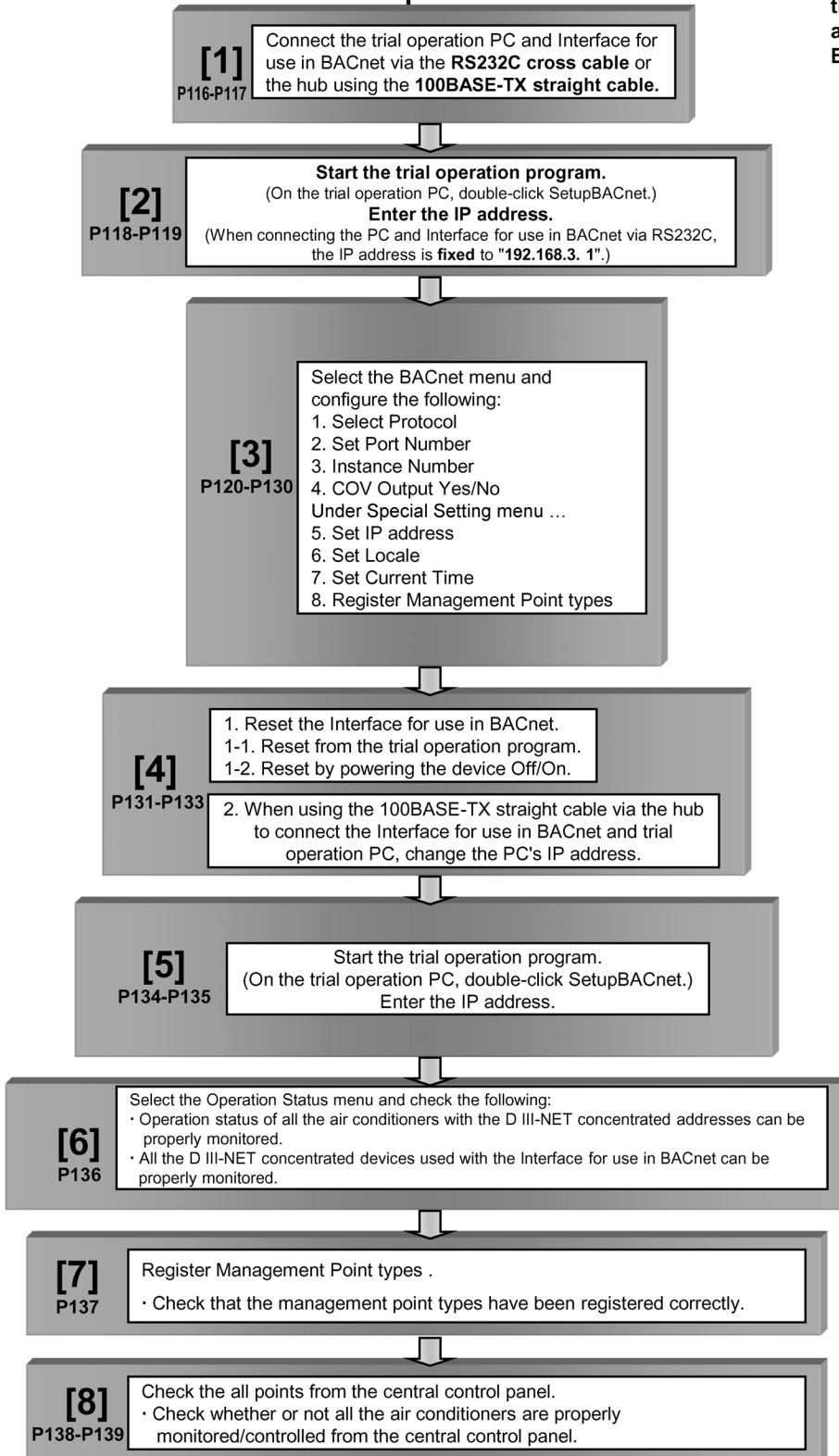

IP address set with the trial operation PC when connecting the Interface for use in BACnet and the trial operation PC via Ethernet.

IP address originally set with the PC.

If the IP address of Interface for use in BACnet has not been changed from the factory setting, change the trial operation PC's IP address to 192.168.0.2. (*) Factory-set IP address of Interface for use in BACnet is 192.168.0.1.

Since the IP address of Interface for use in BACnet has been changed as required at the site in [3]-5, the trial operation PC's IP address should also be changed to the IP address temporarily used for the **trial service operation** ([6]-2 on P.104). (*) You cannot connect to the Interface for use in BACnet unless the IP address is changed.

Return the IP address to the address originally set with the PC.

5.1 Connect the Trial Operation PC and Interface for use in BACnet® Via the RS232C Cross Cable or the Hub Using the 100BASE-TX Straight Cable

[1] Connect the trial operation PC and Interface for use in BACnet via the RS232C cross cable or the hub using the 100BASE-TX straight cable.

[Trial operation PC and Interface for use in BACnet Connection Diagram]

You can connect the trial operation PC and the Interface for use in BACnet in the following 3 methods. Although you can use any of these methods, the method *2 does not allow for BACnet communication. Therefore, if the object requires BACnet communication, use this method only for the setup before the actual operation.

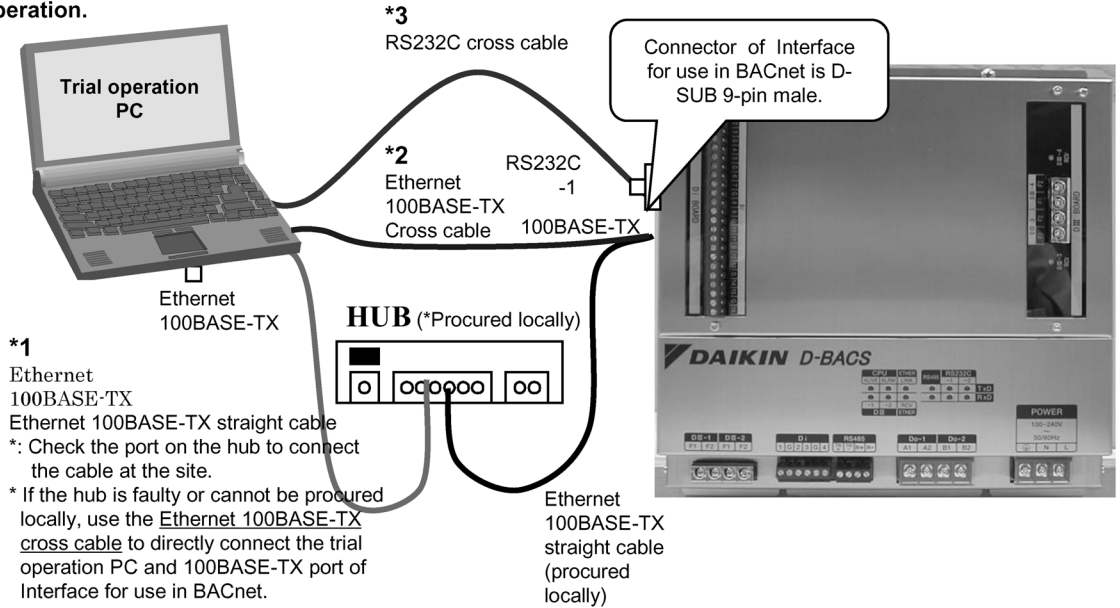

***1**
Ethernet 100BASE-TX
Ethernet 100BASE-TX straight cable
*: Check the port on the hub to connect the cable at the site.
* If the hub is faulty or cannot be procured locally, use the Ethernet 100BASE-TX cross cable to directly connect the trial operation PC and 100BASE-TX port of Interface for use in BACnet.

(You can connect the trial operation PC in one of the three ways. You can use any method.):

*** 1: Use the 100BASE-TX straight cable. The following conditions must be satisfied when using the 100BASE-TX straight cable:**

- The 100BASE-TX straight cable (LAN straight cable) should be used. (This type of cable is sold at a common electrical store.) Also prepare the 100BASE-TX cross cable (LAN cross cable) which can be used when the hub is faulty.
- One free port should be reserved with the hub (procured locally) shown above. Also, an IP address which can be temporarily used at the on-site test should be provided (ask the sales division or site).
- You should be able to change the IP address of the trial operation PC and return to the original address after the test (refer to the next for the procedure).

(Note) If you are executing trial operations for multiple Interface for use in BACnet using the same object, be sure to keep the Interface for use in BACnet powered off or the 100BASE-TX cable disconnected until the whole procedure of [4] in this manual has been completed.

(All Interface for use in BACnet have the identical IP address set at the factory. Therefore, if you connect them to the trial operation PC via the hub using 100BASE-TX, the trial operation may not be executed properly since their default addresses are the same.)

*: Using the 100BASE-TX straight cable for the trial operation ensures faster communication than using RS232C and allows quicker settings.

*: If the IP address of Interface for use in BACnet has been changed from the trial operation PC and the new address is unknown, you can only connect the Interface for use in BACnet and PC using the RS232C cross cable (method *3).

In this case, be sure to set up the trial operation PC's modem as instructed in "3. Setting the Trial Operation PC Modem" of [Before Visiting the Site]. (You can change connection to the 100BASE-TX cable once you find the IP address of Interface for use in BACnet with RS232C cable connection.)

***2: Use the 100BASE-TX cross cable to directly connect the PC and Interface for use in BACnet.**
Refer to *1 for the precautions.

*** 3: Use the RS232C cable to connect the PC and Interface for use in BACnet.**
Use the cable with the specifications shown to the right.
: 9-pin (female) - 9-pin (female) cross cable

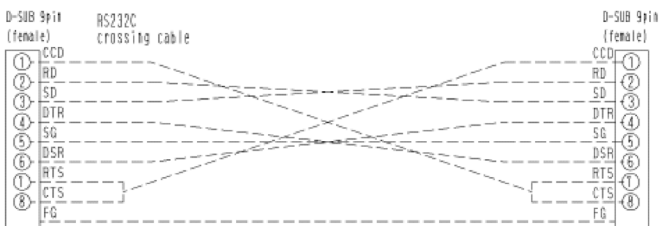

[How to set the PC's IP address when connecting the PC and Interface for use in BACnet via the 100BASE-TX cable]

1. Take a note of the trial operation PC's current IP address. (Be sure to take a note of the current IP address because this address needs to be restored after the trial operation.)
 - 1-1. Start the trial operation PC. (The screens shown below are Windows XP's examples, and the actual screens differ depending on the OS used.)
 - 1-2. Double-click the Network Connections icon on the Control Panel. Click the Local Area Connection and right-click to choose "Properties". The dialog box 1 below opens.
 - 1-3. Select "Internet Protocol (TCP/IP)" [1] and click the Properties button [2]. The dialog box 2 opens. This dialog box shows the trial operation PC's current IP address [3], subnet mask [4], and default gateway address [5]. Take a note of this information in Table 1.

Dialog box 1. Local Area Connection Properties

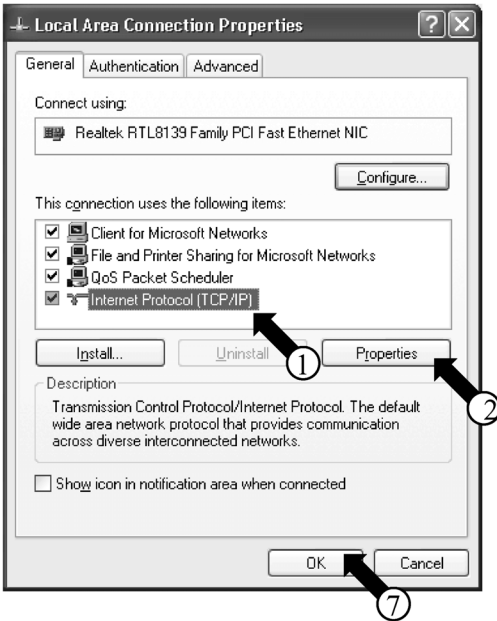

Dialog box 2. Internet Protocol (TCP/IP) Properties

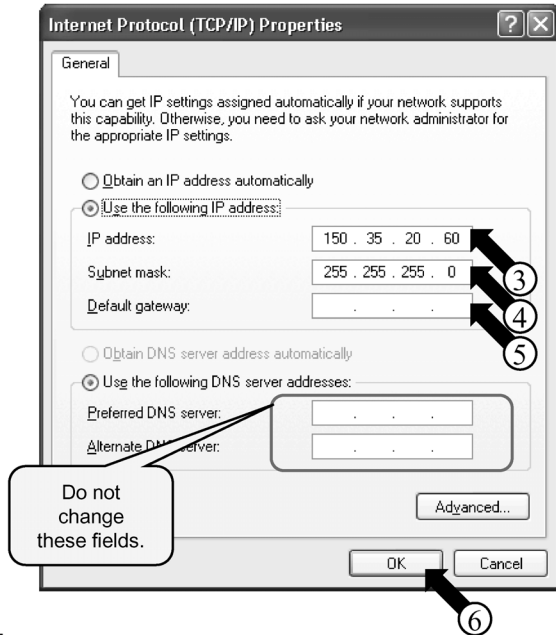

5

[Table 1: Trial Operation PC's Current Address]

[3] IP address		Ex.150.35.20.60
[4] Subnet mask		Ex.255.255.255.0
[5] Default gateway address		Ex.150.35.20.254

2. Change the trial operation PC's IP address.
 - *: Use one of the following IP address depending on the current status of the Interface for use in BACnet.
 - (1): If the IP address of Interface for use in BACnet has not been changed from the factory setting, use the following:
 - IP address: 192.168.0.2
 - Subnet mask: 255.255.255.0
 - Default gateway address: 192.168.0.100
 - (2): If the IP address of Interface for use in BACnet has been changed from the factory setting at the site, use the following:
 - IP address shown in the table in "[6]-2. IP address temporarily used for the trial service operation" on P.104.
- 2-1. Enter the information above in "IP address" [3], "subnet mask" [4], and "default gateway" [5] in the dialog box 2 of Step 1-3, and press the OK button [6]. The dialog box 1 reappears. Click the OK or Cancel button [7].
- 2-2. Reboot the PC as required by the PC. (Reboot may not be necessary depending on the Windows version. Reboot the PC only when requested.)
3. Return the IP address to the original address after the trial operation. (Be sure to return the trial operation PC's IP address to the original address.)
 - 3-1. Return the trial operation PC's IP address to the original address recorded in Step 1-3, as instructed in Steps 2-1 and 2-2.

5.2 Start the Trial Operation Program. (On the Trial Operation PC, Double-click SetupBACnet®.) Enter the IP Address

[2] Start the trial operation program.
(On the trial operation PC, double-click SetupBACnet.)
Enter the IP address.

[When connecting the trial operation PC and Interface for use in BACnet via 100BASE-TX]

1. Before starting the trial operation program, check if the local time zone is correctly selected with the PC's "Date and Time Property". If it is not, the correct time cannot be set.
On the dialog box 1, double-click the trial operation program (SetupBACnet) [1].
The dialog box 2 opens to enter the IP address.
2. Enter the IP address as instructed below in the IP Address field [2].
 - When the IP address of Interface for use in BACnet has not been changed from the factory setting
→ Enter "192.168.0.1".
* In this case, change the trial operation PC's IP address to "192.168.0.2" (refer to P.117 for the procedure).
 - When the IP address of Interface for use in BACnet has been changed from the factory setting at the site
→ Enter the IP address as instructed in [6]-1 on P.104.
* In this case, change the trial operation PC's IP address to the IP address given in [6] on P.104 (refer to P.117 for the procedure).
3. Click the OK button [3]. The dialog box 3 at the bottom of this page opens.

Dialog box 1. SetupBACnet.exe



Dialog box 2. IP Address Entering Dialog box

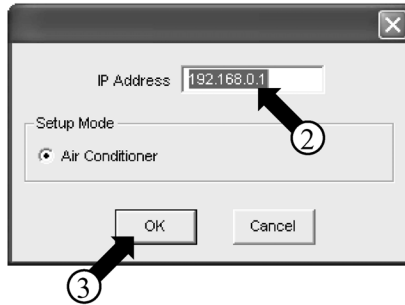

* Refer to P.117 for how to change the IP address.

Dialog box 3. Malfunction History

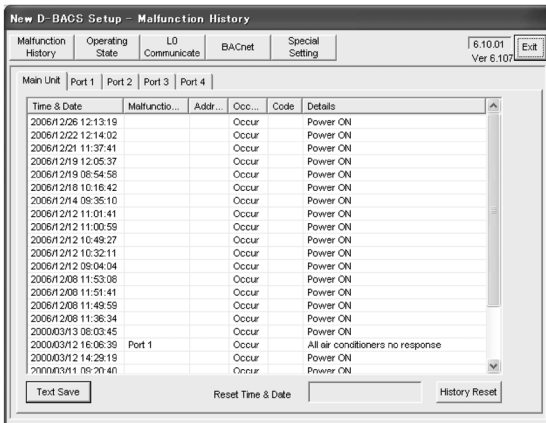

Reference: Interface for use in BACnet and trial operation PC's IP addresses

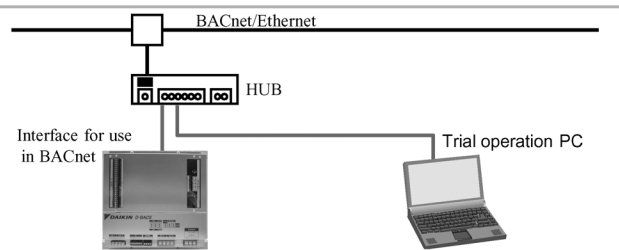

When connecting the Interface for use in BACnet and the trial operation PC via Ethernet, they cannot communicate with each other unless the following IP address settings are used.

Status	IP address of Interface for use in BACnet	Trial operation PC's IP address
Interface for use in BACnet Factory setting	192.168.0.1	192.168.0.2
IP address of Interface for use in BACnet has been changed at the site	IP address set for the Interface for use in BACnet in [6]-1 on P.11.	IP address temporarily used for the trial service operation in [6]-2 on P.11.

CB06A069E

[2] Start the trial operation program.
 (On the trial operation PC, double-click SetupBACnet.)
Enter the IP address.
 (When connecting the PC and Interface for use in BACnet via RS232C,
 the IP address is fixed to "192.168.3. 1".)

[When connecting the trial operation PC and Interface for use in BACnet via RS232C]

1. Set up the modem as instructed in "3. Setting the Trial Operation PC Modem" in [Before Visiting the Site].
2. Connect the trial operation PC and RS232C-1 port of Interface for use in BACnet with the RS232C cross cable (9-pin-9-pin).



3. Double-click the dial-up shortcut () on the desktop.

4. When the dialog box below opens, click the Dial button [1]. The icon shown below right will appear on the task bar (bottom right of the screen).

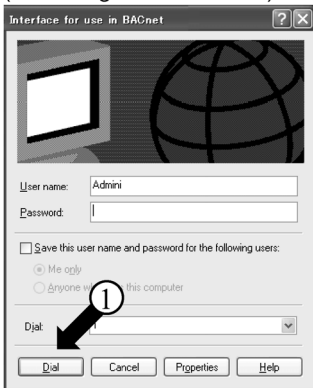

5

5. Before starting the trial operation program, check if the local time zone is correctly selected with the PC's "Date and Time Property". If it is not, the correct time cannot be set.
 On the dialog box 1, double-click the trial operation program (SetupBACnet) [2]. The IP address entering dialog box opens.
6. Change the IP address to "192.168.3.1" and click the OK button [3].
 The dialog box shown at the bottom of this page opens.

Dialog box 1. SetupBACnet.exe



Dialog box 2. Entering IP address

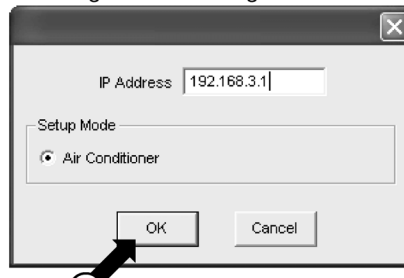

Dialog box 3. Malfunction History

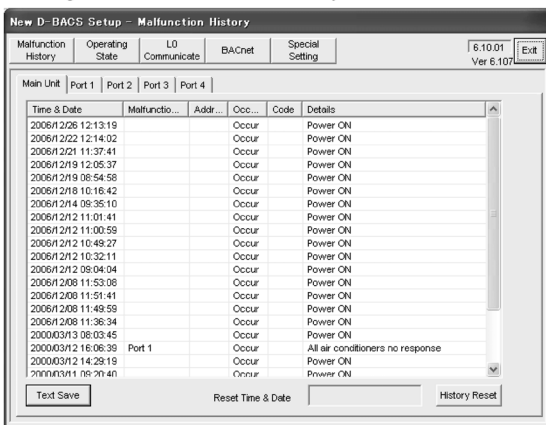

5.3 Setting

5.3.1 Select Protocol

[3]

Select the BACnet menu and configure the following:

1. **Select Protocol**
2. Set Port Number
3. Instance Number
4. COV Output Yes/No

Under **Special Setting** menu ...

5. Set IP address
6. Set Locale
7. Set Current Time
8. Register Management Point types

Note
Be sure that the Backup switch on the right side of the Interface for use in BACnet is ON. If not, turn it ON (by shifting the switch knob to the bottom position).

1. Select the BACnet protocol.

- 1-1. Click the BACnet button [1].
- 1-2. Click the Protocol button [2].
- 1-3. The Current protocol of Interface for use in BACnet is shown in [3].
- 1-4. If the protocol needs to be changed, click the Modify button [4].
- 1-5. The dialog box 2. "BACnet Protocol Setting" opens. Select "IPv4 BACnet/IP" [5] according to the information in [1] of "2. Obtaining Object Information", and click the Set button [6].
- 1-6. The dialog box 3 opens to request for reset by powering the Interface for use in BACnet Off then On again. Click the OK button [7].

Reset the Interface for use in BACnet after you completing all the necessary settings.

***: The setting will take effect after the Interface for use in BACnet is reset by powering it Off then On again.**

Dialog box 1. BACnet

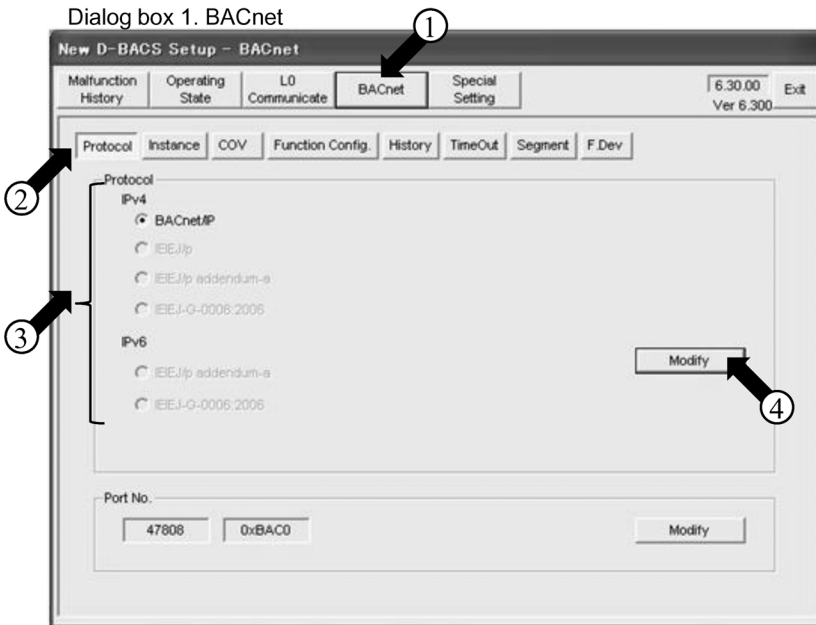

Dialog box 2. BACnet Protocol Setting



Dialog box 3. Reset Request

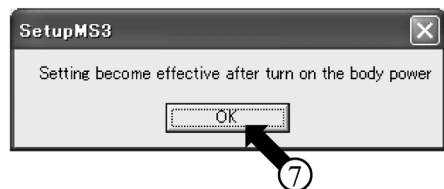

5.3.2 Set Port Number

[3]

Select the BACnet menu and configure the following:

1. Select Protocol
- 2. Set Port Number**
3. Instance Number
4. COV Output Yes/No

Under **Special Setting** menu ...

5. Set IP address
6. Set Locale
7. Set Current Time
8. Register Management Point types

2. Set the communication port number.

- 2-1. Click the BACnet button [1].
- 2-2. Click the Protocol button [2].
- 2-3. Current port number of Interface for use in BACnet is shown in [3].
- 2-4. If the port number needs to be changed, click the Modify button [4].
- 2-5. The dialog box 2 "BACnet Port No. Setting" opens. Use the ▲▼ buttons to select the port number [5] according to the information in [1] of "2. Obtaining Object Information", and click the Set button [6].
- 2-6. The dialog box 3 opens for request for reset by powering the Interface for use in BACnet Off then On again. Click the OK button [7].

Reset the Interface for use in BACnet after you completing all the necessary settings.

***: The setting will take effect after the Interface for use in BACnet is reset by powering it Off then On again.**

Dialog box 1. BACnet

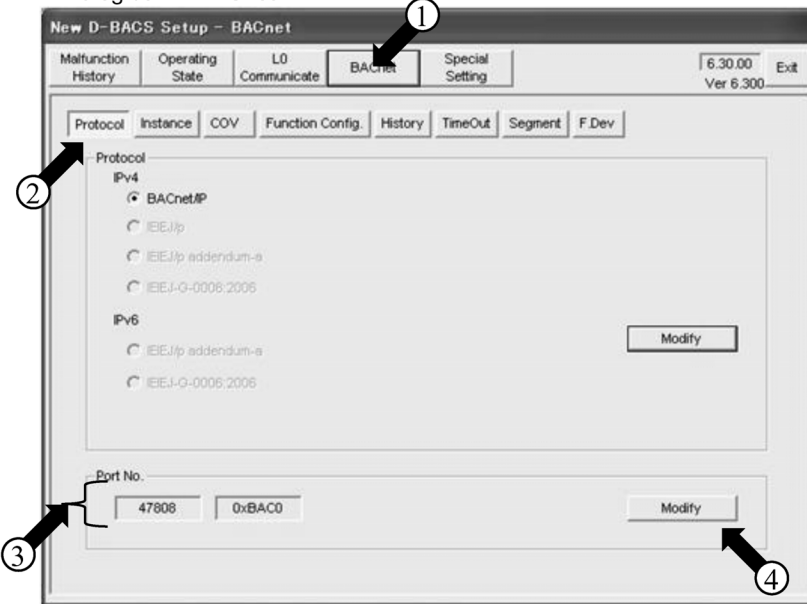

Dialog box 2. BACnet Port No. Setting

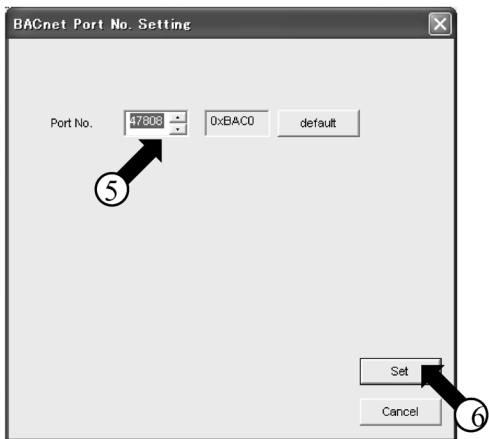

Dialog box 3. Reset Request

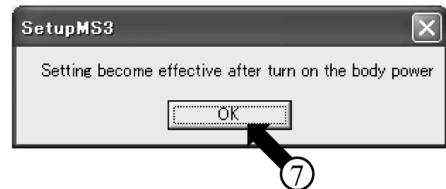

5

5.3.3 Instance Number

[3]

Select the BACnet menu and configure the following:

1. Select Protocol
2. Set Port Number
- 3. Instance Number**
4. COV Output Yes/No
- Under **Special Setting** menu ...
5. Set IP address
6. Set Locale
7. Set Current Time
8. Register Management Point types

* The device instance number is determined by the central control panel vendor at the object meeting. This section shows the steps to set the provided number with the Interface for use in BACnet.

3. Set the Device instance number of Interface for use in BACnet.

Check the [3] " The device instance number of Interface for use in BACnet" in "2. Obtaining Object Information" of this manual. The following steps set the instance number with the Interface for use in BACnet.

- 3-1. Click the BACnet button [1].
- 3-2. Click the Instance button [2].
- 3-3. The current device instance number of Interface for use in BACnet is shown in [3].
- 3-4. If the current device instance number of Interface for use in BACnet is different from the desired number, click the Modify button [4]. (If modification is not required, proceed to the next page.)
- 3-5. The BACnet Device Setting dialog box opens. Use the ▲▼ buttons to select the device instance number [5] and click the Set button [6].
- 3-6. The dialog box 3 opens to request for reset by powering the Interface for use in BACnet Off then On again. Click the OK button [7].

Reset the Interface for use in BACnet after you completing all the necessary settings.

***: The setting will take effect after the Interface for use in BACnet is reset by powering it Off then On again.**

Dialog box 1. BACnet

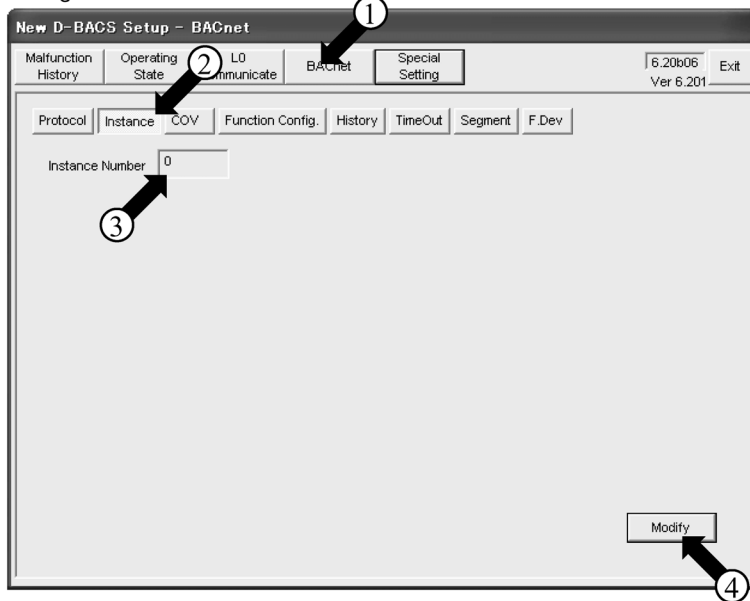

Dialog box 2. BACnet Device Setting



Dialog box 3. Reset Request

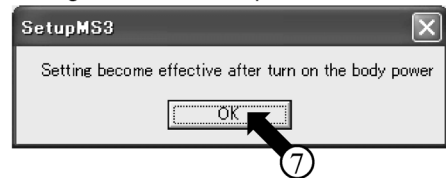

5.3.4 COV Output Yes/No

[3]

Select the BACnet menu and configure the following:

1. Select Protocol
2. Set Port Number
3. Instance Number
4. **COV Output Yes/No**
Under Special Setting menu ...
5. Set IP address
6. Set Locale
7. Set Current Time
8. Register Management Point types

•The COV function allows the Interface for use in BACnet to automatically transmit data whenever an air conditioner changes its status.

When using the BACnet/IP protocol, this setting is not required because the central control panel communicates with each air conditioner for this setting.

4. Set the COV output. (When using the BACnet/IP protocol, this setting is not required because the central control panel communicates with each air conditioner for this setting.)

- 4-1. Click the BACnet button [1].
- 4-2. Click the COV button [2].
- 4-3. Select the COV for each air conditioner or COV for each air conditioner block in [3]. (Block setting may not be necessary for some cases.)
- 4-4. The current COV output setting of Interface for use in BACnet is shown in [4]. Use the scroll bar [5] to see the entire list.
- 4-5. If the current COV output setting of Interface for use in BACnet needs to be changed, click the Modify button [6]. (If modification is not required, proceed to the next page.)
- 4-6. The dialog box 2 "BACnet COV Setting" opens. Check the box [7] of each item to output COV. Use the scroll bar [8] to set (or confirm) all the items, click the Set button [9].
- 4-7. To save the COV output setting data in the trial operation PC, click the Text Save button [10] (this step is optional). The dialog box "Save As" opens. Enter a unique name to identify the setting data.

5

Dialog box 1. BACnet

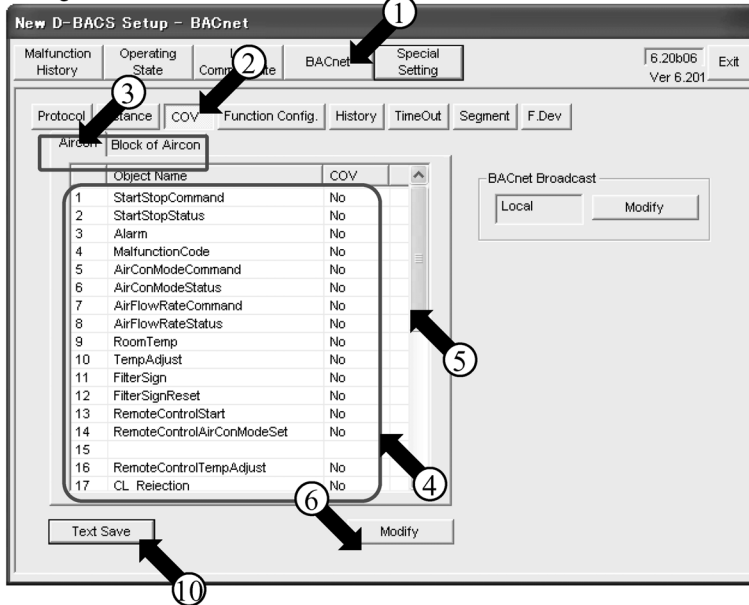

Dialog box 2. BACnet COV Setting

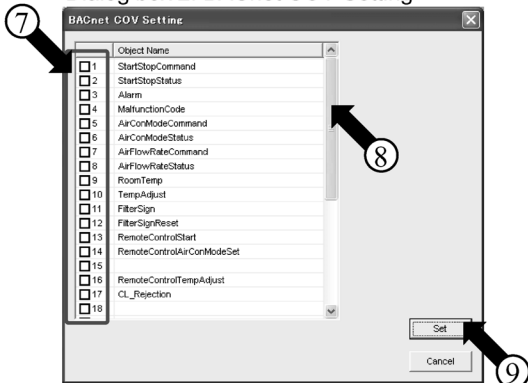

[3]

Select the BACnet menu and configure the following:

1. Select Protocol
2. Set Port Number
3. Instance Number
- 4. COV Output Yes/No**
- Under **Special Setting** menu ...
5. Set IP address
6. Set Locale
7. Set Current Time
8. Register Management Point types

Note: This setting can be changed only when the communication protocol is BACnet/IP, but not for other protocols.

4. Set the COV setting (continued from the previous page).

Refer to [5] "BACnet Broadcast" in "2. Obtaining Object Information" of this manual.

This section shows the steps to set the BACnet broadcast method to the Interface for use in BACnet as required.

4-8. The current BACnet broadcast method of Interface for use in BACnet is shown in [11].

4-9. If the current setting needs to be changed, click the Modify button [12]. The dialog box 2 "BACnet Broadcast Setting" opens.

4-10. Select "Local" or "Global" in [13], and click the Set button [14].

Dialog box 1. BACnet

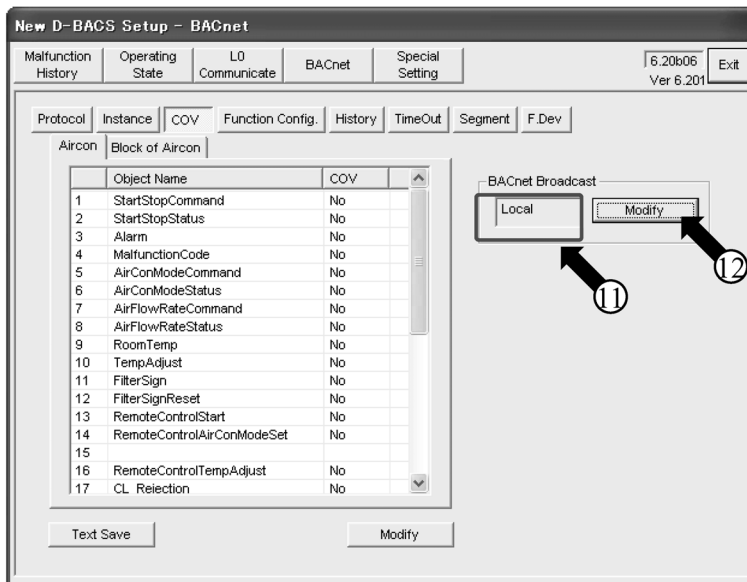

Dialog box 2. BACnet Broadcast Setting

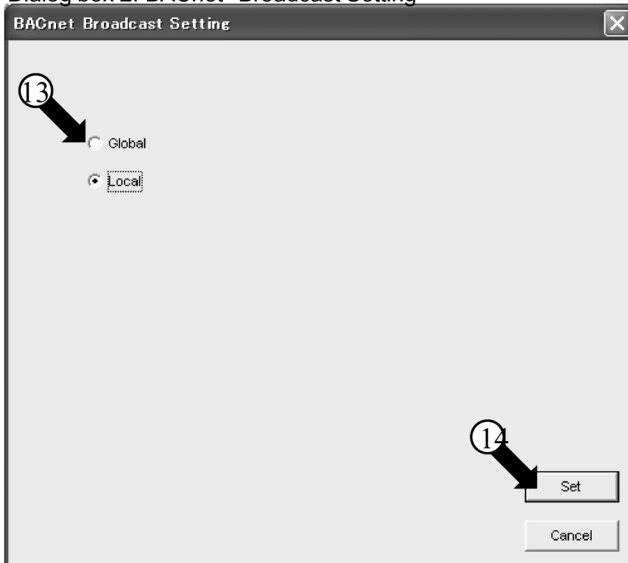

5.3.5 Set IP Address

[3] Select the BACnet menu and configure the following:

1. Select Protocol
2. Set Port Number
3. Instance Number
4. COV Output Yes/No
- Under **Special Setting** menu ...
- 5. Set IP address**
6. Set Locale
7. Set Current Time
8. Register Management Point types

Restriction on IPv4 address (The following addresses cannot be used.)

One of the following invalid addresses is used as the IP address:

- An address outside the range of the Class A - C addresses (1.0.0.0 - 223.255.255.255)
- A loop-back address (127.0.0.0 - 127.255.255.255)
- An address of which the host portion (hexadecimal "0" portion of subnet mask) contains all "0"s or "1"s
- An address of which the network portion (hexadecimal "1" portion of subnet mask) contains all "0"s or "1"s

[Example]

- 244.1.1.1 -> NG (outside the range of Class A - C addresses)
- 127.0.0.1 -> NG (Loop-back address)
- IP: 198.168.1.0/Subnet: 255.255.255.0 -> NG (host portion contains all "0"s.)
- IP: 192.168.0.1/Subnet: 192.0.0.0 -> NG (network portion contains all "1"s.)

One of the following invalid addresses is used as the default gateway address:

- An address outside the range of the Class A - C addresses (1.0.0.0 - 223.255.255.255)
- A loop-back address (127.0.0.0 - 127.255.255.255)

An invalid address is used for the subnet mask (outside the range 128.0.0.0 - 255.255.255.255, hexadecimal "1" portion contain non-sequential value or blank).

[Example]

- 255.255.255.244 -> NG (hexadecimal "1" portion contain non-sequential value.)

5. Set the IP address of Interface for use in BACnet, subnet mask, and default gateway address.

Refer to [6] "IPv4 address" in "2. Obtaining Object Information" of this manual.

This section shows the steps to set this IP address data to the Interface for use in BACnet.

5-1. Click the Special Setting button [1].

5-2. Click the IP Address button [2].

5-3. The current IP address of Interface for use in BACnet, subnet mask, and default gateway address are shown in [3].

5-4. If the current IP address of Interface for use in BACnet, subnet mask, and default gateway address are different from the desired settings, click the Modify button [4].

(If modification is not required, proceed to the next page.)

5-5. The dialog box 2 "IP Address Setting" opens. Enter desired values from the PC's keyboard into [5], then click the Set button [6].

5-6. The dialog box 3 opens to request for reset by powering the Interface for use in BACnet Off then On again. Click the OK button [7].

Reset the Interface for use in BACnet after you completing all the necessary settings.

***: The setting will take effect after the interface for use in BACnet is reset by powering it Off then On again.**

5

Dialog box 1. Special Setting

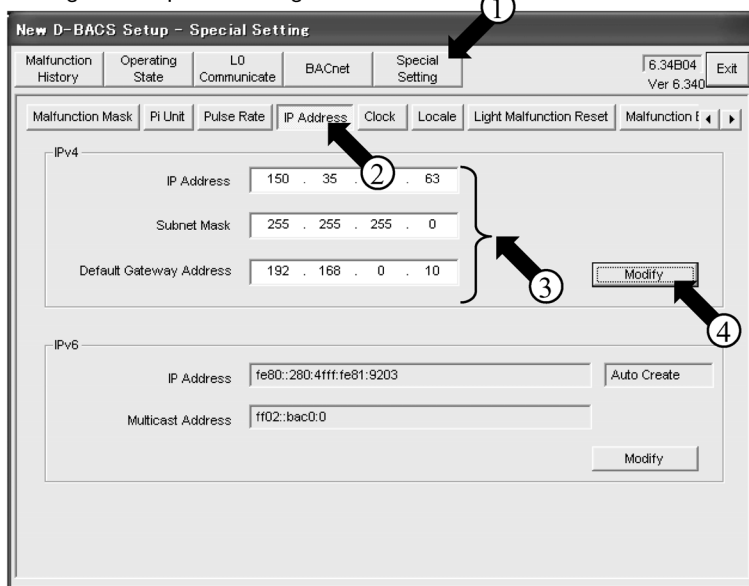

Dialog box 2. IP Address Setting

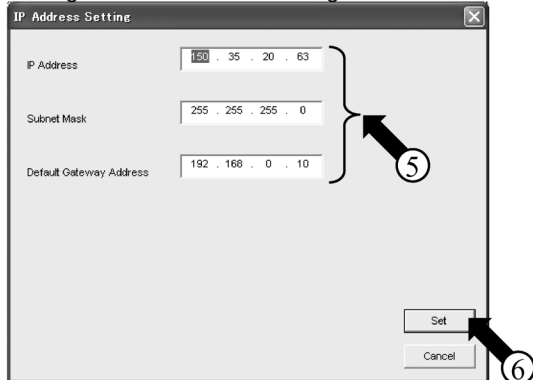

Dialog box 3. Reset Request

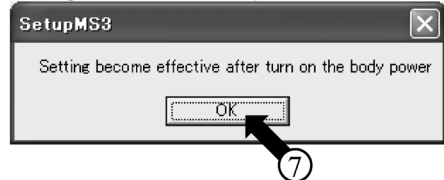

[3]

Select the BACnet menu and configure the following:

1. Select Protocol
2. Set Port Number
3. Instance Number
4. COV Output Yes/No

Under **Special Setting** menu ...

5. Set IP address

6. Set Locale
7. Set Current Time
8. Register Management Point types

Acceptable IPv6 address is as follows:

[Address]

- XXXX:XXXX:XXXX:XXXX:XXXX:XXXX:XXXX
- XXXX::XXXX
- XXXX::
- ::ddd.ddd.ddd.ddd
- XXXX:XXXX:XXXX:XXXX:XXXX:XXXX:ddd.ddd.ddd.ddd
- XXXX:XXXX:ddd.ddd.ddd.ddd
- XXXX::ddd.ddd.ddd.ddd
- ::XXXX:ddd.ddd.ddd.ddd
- ::XXXX

* X: Hexadecimal
 d: Decimal
 * Allowed characters: 0 - 9, A - F (a - f), colon (:), and period (.)

5. Set the IPv6 self IP address of Interface for use in BACnet and multicast address.

If there is no device performing IPv6 communication on the same network, this setting is not required.

- 5-7. Click the Special Setting button [1].
- 5-8. Click the IP Address button [2].
- 5-9. The current IPv6 self address of Interface for use in BACnet, multicast address are shown in [3].
- 5-10. If the current IPv6 self address and multicast address are different from the desired settings, click the Modify button [4].
 (If modification is not required, proceed to the next page.)
- 5-11. The dialog box 2 "IPv6 Address Setting" opens. Enter desired values from the PC's keyboard into [5], then click the Set button [6].
- 5-12. The dialog box 3 opens to request for reset by powering the Interface for use in BACnet Off then On again. Click the OK button [7].

Reset the Interface for use in BACnet after you completing all the necessary settings.

***: The setting will take effect after the Interface for use in BACnet is reset by powering it Off then On again.**

Dialog box 1. Special Setting

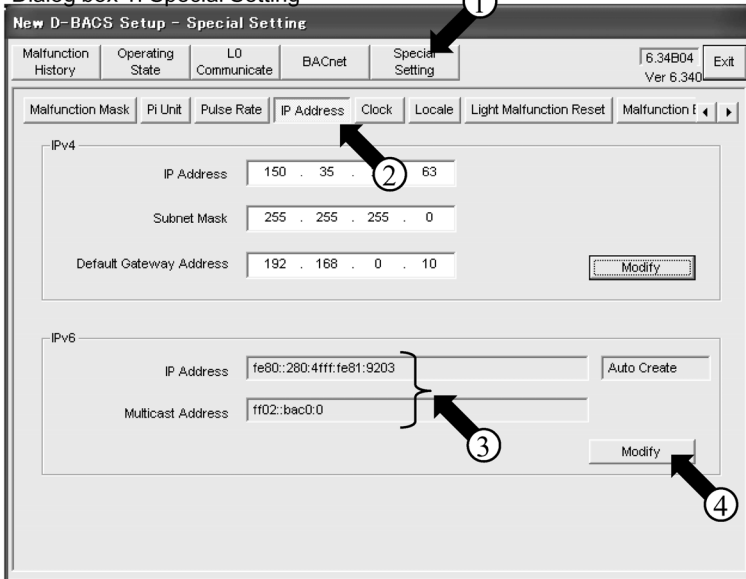

Dialog box 2. IPv6 Address Setting

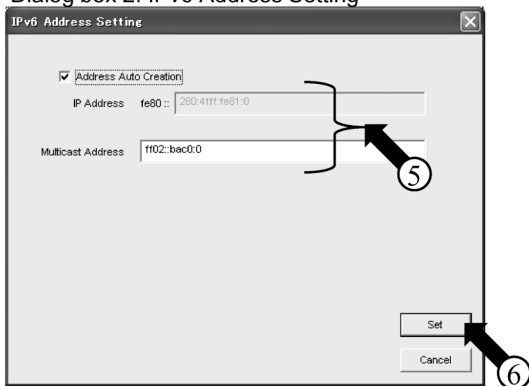

Dialog box 3. Reset Request

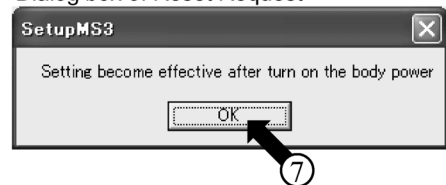

5.3.6 Set Locale

[3]

Select the BACnet menu and configure the following:

1. Select Protocol
2. Set Port Number
3. Instance Number
4. COV Output Yes/No
5. Set IP address
- 6. Set Locale**
7. Set Current Time
8. Register Management Point types

[About time Zone]

The Interface for use in BACnet is intended to be an international software program.

Time Zone is popular in oversea markets and used with PC products. This is because time bias selection for Japan is required for the trial operation. (GMT+09: 00) Seoul, Yakutsk, and Tokyo

[About temperature unit(Celsius/Fahrenheit)]

Set the unit for the temperature sent/received to/from the central monitoring panel in BACnet communications to either "Celsius" or "Fahrenheit."

"Celsius" is set as factory default.

6. Set Locale of Interface for use in BACnet.

6-1. Click the Special Setting button [1].

6-2. Click the Set Locale button [2].

6-3. The current time bias of Interface for use in BACnet is shown in [3], and the current temperature unit(Celsius/Fahrenheit) is shown in [4] and current

6-4. The current time bias is shown for the current location, and the current temperature unit(Celsius/Fahrenheit) is shown for the the current setting.

If these settings need to be changed, click the Modify button [5].

(If modification is not required, proceed to the next page.)

6-5. The dialog box 2 "Locale" opens. Use the ▼ button [6] to select the location, and Select "Celsius" or "Fahrenheit" in [7], and click the Set button [8].

6-6. The dialog box 3 opens to request for reset by powering the Interface for use in BACnet Off then On again. Click the OK button [9].

Reset the Interface for use in BACnet after you completing all the necessary settings.

***: The setting will take effect after the Interface for use in BACnet is reset by powering it Off then On again.**

Dialog box 1. Special Setting

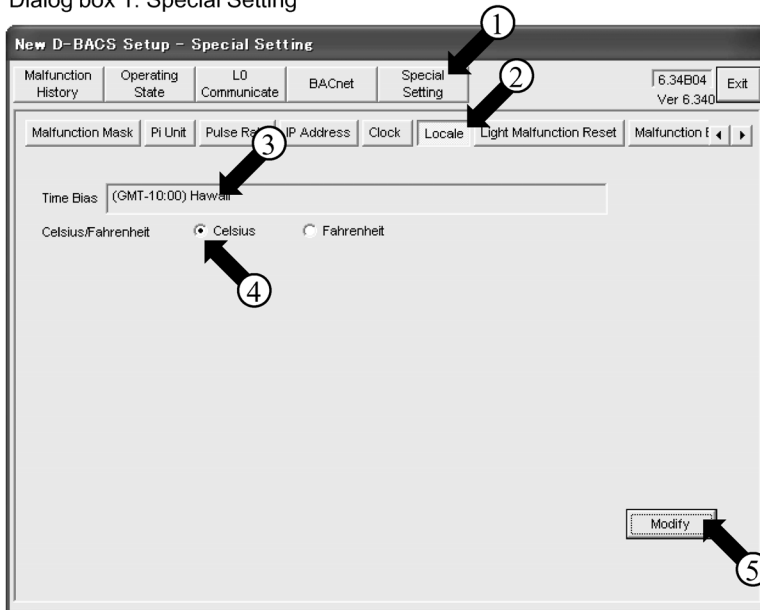

Dialog box 2. Locale

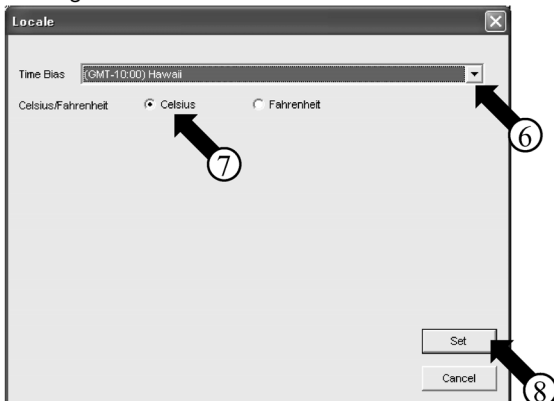

Dialog box 3. Reset Request

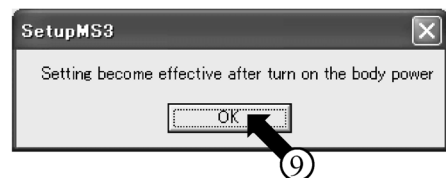

5.3.7 Set Current Time

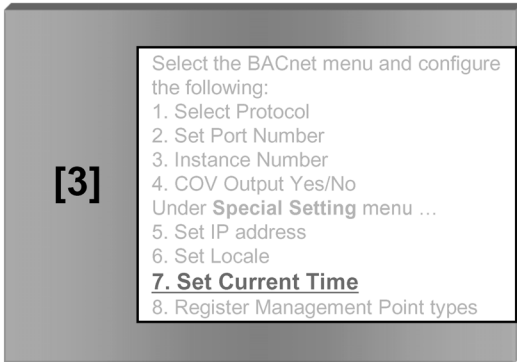

7. Set the current time to the Interface for use in BACnet.

7-1. Click the Special Setting button [1].

7-2. Click the Clock button [2].

7-3. The current time of Interface for use in BACnet is shown in [3].

7-4. If the time is not correct, click the Modify button [4].

(If modification is not required, proceed to the next page.)

7-5. The dialog box 2 "Clock Setting" opens. Use the ▲▼ buttons [5] to adjust the time and click the Set button [6].

*: The time does not need to be very precise (i.e., difference of around ten seconds is acceptable here).

Dialog box 1. Special Setting

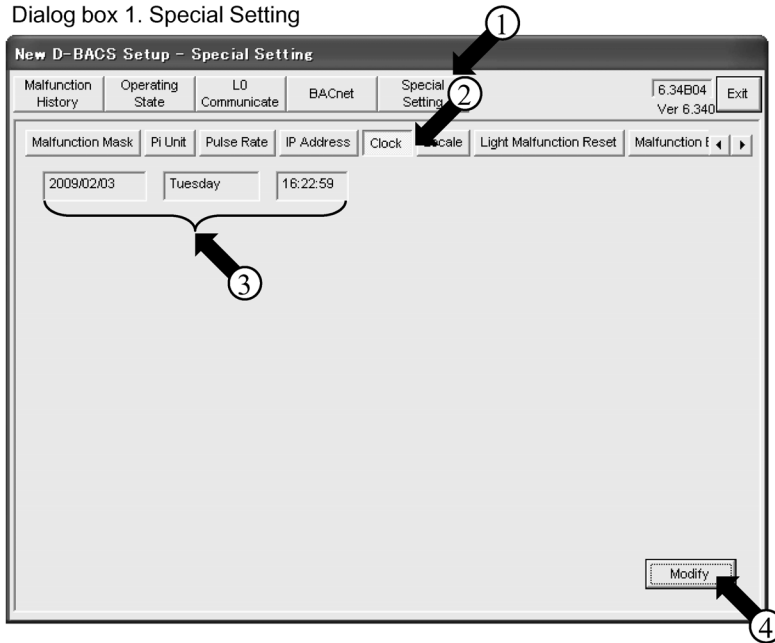

Dialog box 2. Clock Setting

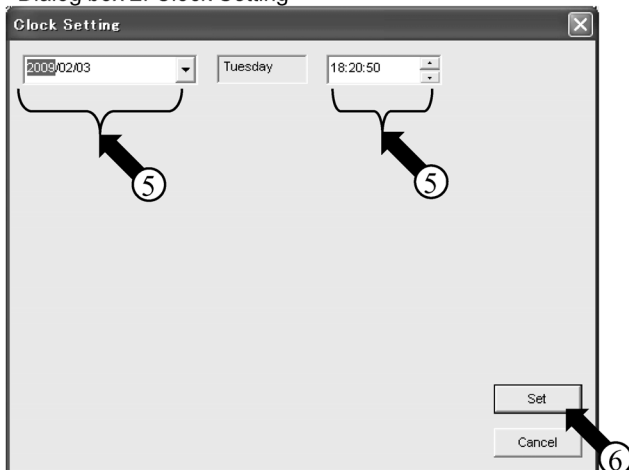

5.3.8 Register Management Point Types

[3]

Select the BACnet menu and configure the following:

1. Select Protocol
2. Set Port Number
3. Set Instance Number
4. Set COV Output Yes/No

Under **Special Setting** menu ...

5. Set IP address
6. Set Locale
7. Set Current Time
- 8. Register Management Point Types**

8. Update the management point type for each equipment connected to the Interface for use in BACnet.

[When to use this item?]

- Immediately after installing the Interface for use in BACnet.
- Immediately after adding a new equipment
- Immediately after replacing a connected equipment

*** Refer to the table on next page for necessary cases of when to use this item.**

- 8-1. Click the Special Setting button [1].
- 8-2. Click the Update Points button [2].
- 8-3. The List for update [3] now shows the D III port, central address, and management point type for each update target device.
- 8-4. Click the Refresh button [4] to display the most up-to-date list in the dialog box.

*** It takes a while for the Interface for use in BACnet to detect connected equipments. After connecting a equipments, wait for a few minutes, and then click the Refresh button.**

*** Immediately after installing the Interface for use in BACnet (at factory default), a connected device will be listed in the dialog box if it is "VENTIAIRE(Heat Reclaim Ventilator)," but it will not be listed in the dialog box for other device types (VRV System, SkyAir, etc.)**

*** When an equipment is replaced with the same type of equipment, in such cases as "Indoor" to "Indoor" or "VENTIAIRE (Heat Reclaim Ventilator) " to "VENTIAIRE (Heat Reclaim Ventilator)," the substituted equipment will not be listed in the dialog box.**

- 8-5. After the list in the dialog box displays, click the Update button [5].
- 8-6. The dialog box 2 "Check" opens. Click the Yes button [6].
- 8-7. The dialog box 3 "SetupBACnet" opens. Click the OK button [7].

Perform power resetting upon completion of the above setting procedure.

*** Note that the updated setting is enabled only after power resetting is performed.**

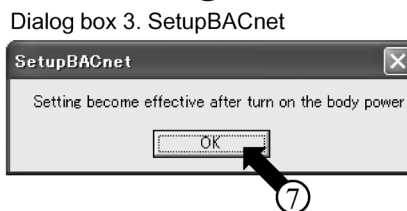
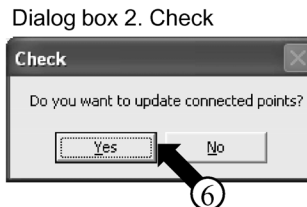
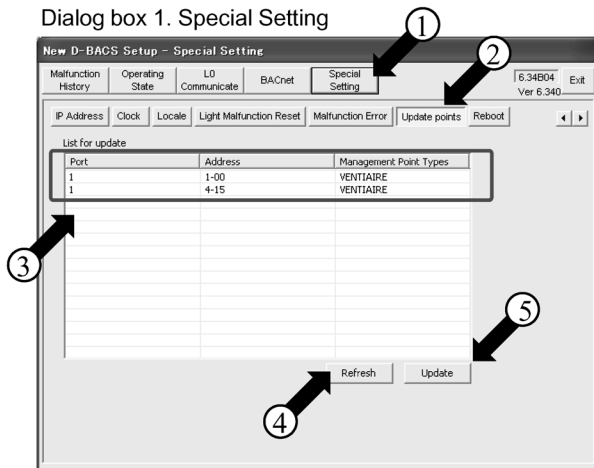

[3]

Select the BACnet menu and configure the following:

1. Select Protocol
2. Set Port Number
3. Set Instance Number
4. Set COV Output Yes/No
Under **Special Setting** menu ...
5. Set IP address
6. Set Local
7. Set Current Time
- 8. Register Management Point Types**

[* Other]

- **VRV System,**
- **SkyAir (interface adaptor for SkyAir series),**
- **Outdoor air processing unit,**
- **Packaged air conditioner (central control adaptor),**
- **Wiring adapter for other air conditioner,**
- **Split (KRP928)**

When	Situation	Change in equipment connected to Interface for use in BACnet		Update required or not	Management point types		
Installation	Install the Interface for use in BACnet and air conditioners.	Equipment to be connected	Connected equipment				
		- (No equipment connected to Interface for use in BACnet)	Heat Reclaim Ventilator			Required	Indoor unit (At factory default) → Heat Reclaim Ventilator
			Other (*)			Not required	Indoor unit (At factory default*)
Operation	Add new air conditioners.	Equipment to be additionally connected	Additionally connected equipment				
		-	Heat Reclaim Ventilator			Required	Indoor unit (At factory default) → Heat Reclaim Ventilator
			Other (*)			Not required	Indoor unit (At factory default*)
Operation	Remove an existing equipment (Decrease)	Equipment to be removed	Removed equipment				
		Heat Reclaim Ventilator	-			Not required	Heat Reclaim Ventilator
		Other (*)				Not required	Indoor unit
Operation	Replace a equipment with another. (Equipment update)	Equipment to be replaced	Substituted equipment				
		Heat Reclaim Ventilator	Other (*)			Required	Heat Reclaim Ventilator → Indoor unit
			Heat Reclaim Ventilator			Not required	Heat Reclaim Ventilator
		Other (*)	Heat Reclaim Ventilator			Required	Indoor unit → Heat Reclaim Ventilator
Other (*)	Not required		Indoor unit				
Operation	Upgrade the software version to enable monitor/control operation with no change to the installed equipments. (Upgrade to Ver. 6.34.00 or later)	Equipment to be upgraded	Upgraded equipment				
		Heat Reclaim Ventilator				Required	Indoor unit → Heat Reclaim Ventilator
		Other (*)				Not required	Indoor unit

CB06A069E

5.4 Reset the Interface for use in BACnet®

[4]

1. Reset the Interface for use in BACnet.
 1-1. Reset from the trial operation program.
 1-2. Reset by powering the device Off/On.

2. When using the 100BASE-TX straight cable via the hub to connect the Interface for use in BACnet and trial operation PC, change the PC's IP address.

You can reset the Interface for use in BACnet in two methods as described in this page and next page. You can use either method.

1-1. To make the new settings effective, reset the Interface for use in BACnet from the trial operation PC.

1-1-1. Click the Special Setting button [1].

1-1-2. Click the Reboot button [2].

1-1-3. Click the Reboot button [3] at the bottom right of the screen. The dialog box 2 "Warning" opens.

1-1-4. Click the OK button [4]. The dialog box 3 "Warning" opens.

1-1-5. Click the OK button [5]. The dialog box 4 "Reboot" opens.

1-1-6. The Interface for use in BACnet will reboot and the dialog box 5 opens to indicate termination of the trial operation program.

1-1-7. Click the OK button [6] to terminate the trial operation program.

Dialog box 1. Special Setting

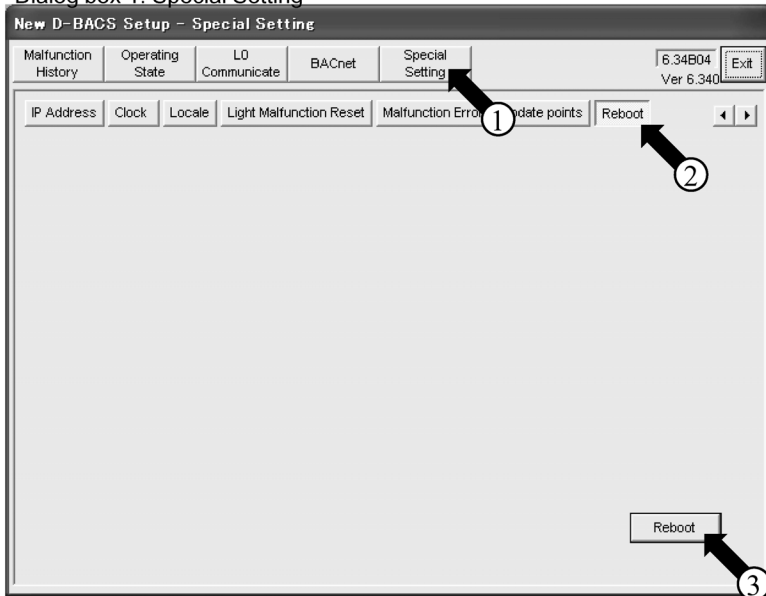

Dialog box 2. Warning

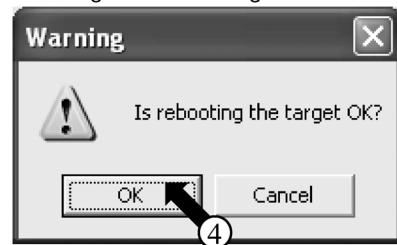

Dialog box 3. Warning

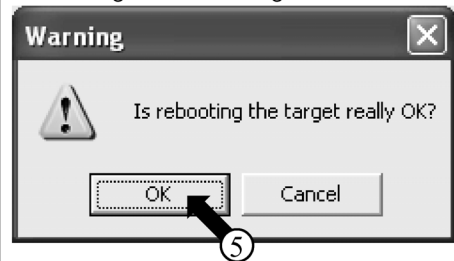

Dialog box 4. Reboot

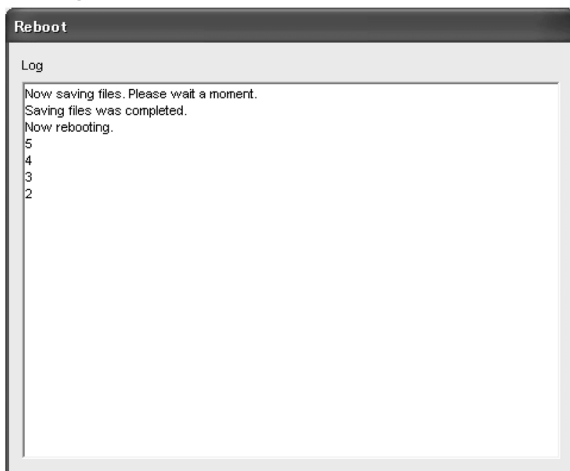

Dialog box 5. Exiting from Program

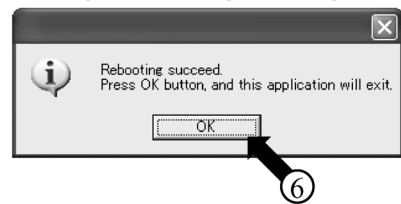

5

[4]

1. Reset the Interface for use in BACnet.
 1-1. Reset from the trial operation program.
 1-2. Reset by powering the device Off/On.

2. When using the 100BASE-TX cable to connect the Interface for use in BACnet and trial operation PC, change the PC's IP address.

You can reset the Interface for use in BACnet in 2 methods as described in the previous page and this page. You can use either method.

1-2. To make the new settings effective, reset the Interface for use in BACnet by powering it Off then On.

1-2-1. Terminate the trial operation program. Click the Exit button [1]. The dialog box 2 opens to confirm the termination.

1-2-2. Click the OK button [2] to terminate the trial operation program.

1-2-3. When you are connecting the PC and the Interface for use in BACnet via RS232C, double-click the icon  at the bottom right of the PC screen (i.e., on the task bar).

The dialog box 3 "Interface for use in BACnet Status" opens. Click the Disconnect button [3] and wait until the device is disconnected and the dialog box 3 disappears.

1-2-4. Power Off then On the Interface for use in BACnet to reset it. The Power switch is located at [4] of the Photo 1 below. Turn this switch Off, then turn it On again after one second.

Dialog box 1. Trial operation program

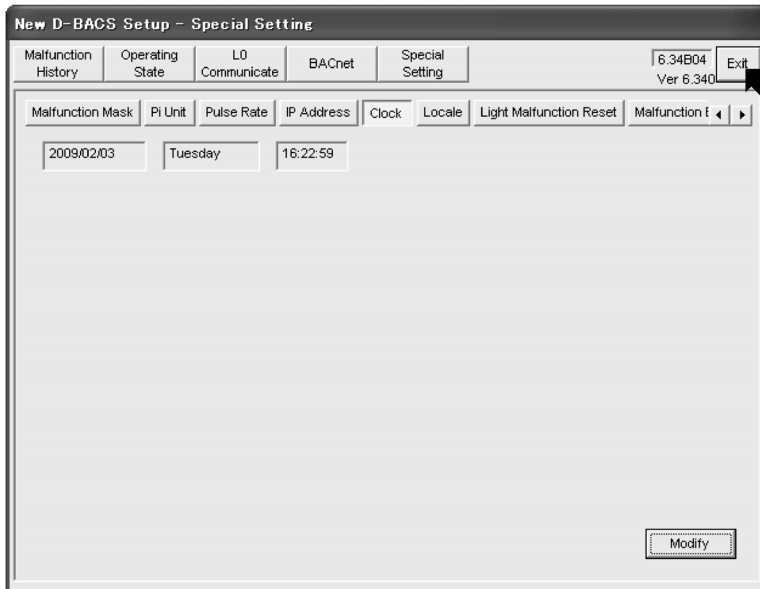

Dialog box 2. Termination confirmation

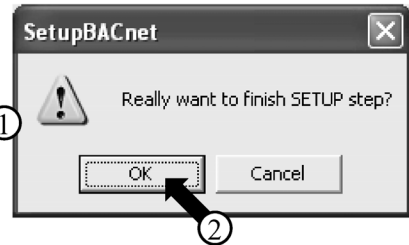

Dialog box 3. Interface for use in BACnet Status

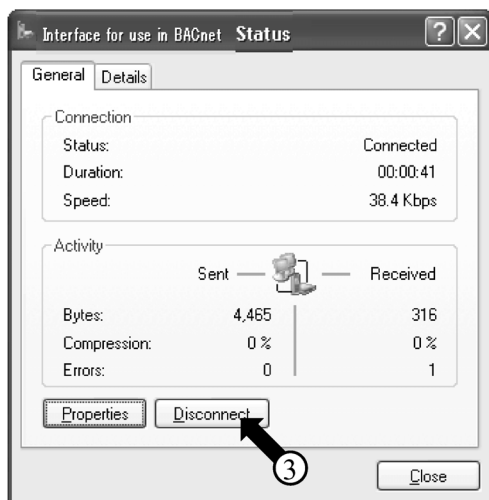

Photo 1. Outer view of Master Station III



[4]

1. Reset the Interface for use in BACnet.
 1-1. Reset from the trial operation program.
 1-2. Reset by powering the device Off/On.

2. When using the 100BASE-TX cable to connect the Interface for use in BACnet and trial operation PC, change the PC's IP address.

3. When using the 100BASE-TX cable to connect the Interface for use in BACnet and trial operation PC, change the PC's IP address.

*: This procedure is not necessary when connecting them via RS232C.

(The screens shown below are Windows XP's examples, and the actual screens differ depending on the OS used.)

- 3-1. Double-click the Network Connections icon on the Control Panel. Click the Local Area Connection and right-click to choose "Properties". The dialog box 1 below opens.
- 3-2. Select "Internet Protocol (TCP/IP)" [1] and click the Properties button [2]. The dialog box 2 opens. This dialog box shows the trial operation PC's current IP address [3], subnet mask [4], and default gateway address [5].
- 3-3. Refer to the table in "[6]-2. IP address temporarily used for the trial service operation" of "2. Obtaining Object Information", and enter the information above in "IP address" [3], "subnet mask" [4], and "default gateway" [5], then click the OK button [6].
 The dialog box 1 reappears. Click the OK button [7].
- 3-4. Reboot the PC as required by the PC.
 (Reboot may not be necessary depending on the Windows version. Reboot the PC only when requested.)

Dialog box 1. Local Area Connection Properties

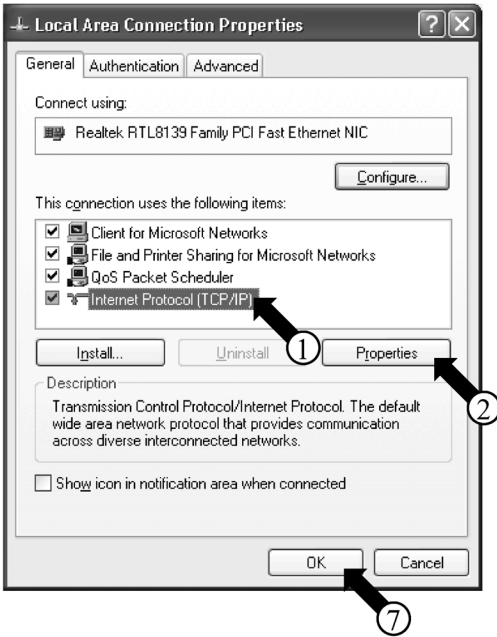

Dialog box 2. Internet Protocol (TCP/IP) Properties

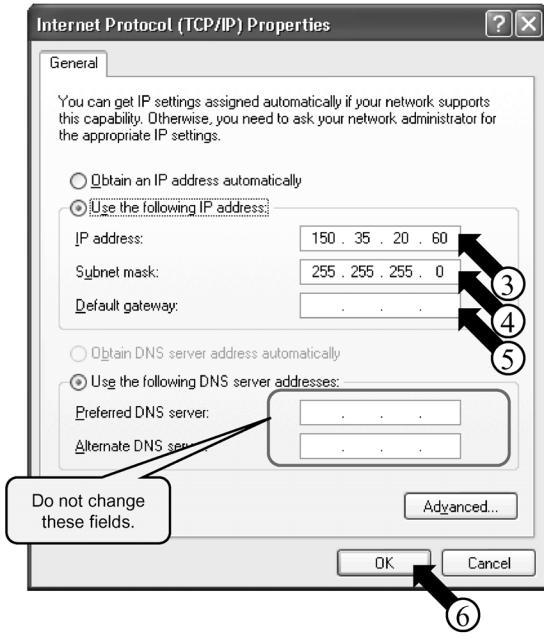

(Note) **Be sure to return the IP address to the original address after the trial operation.**
 Return the trial operation PC's address to the original address recorded in Table 1 on P.24, as directed in Steps 3-1 through 3-4 above.

5.5 Start the Trial Operation Program

[5] Start the trial operation program.
(On the trial operation PC, double-click SetupBACnet.)
Enter the IP address.

[When connecting the trial operation PC and Interface for use in BACnet via 100BASE-TX]

1. Double-click the trial operation program (SetupBACnet) icon [1] on the dialog box 1. Dialog box 2 to enter the IP address opens.
2. Enter the IP address in [2] according to the information in [6]-1 "IP address for Interface for use in BACnet" of "2. Obtaining Object Information".
* The IP address of the trial operation PC needs to be changed to the address shown in [6]-2 of "2. Obtaining Object Information".
3. Click the OK button [3]. The dialog box 3 at the bottom of this page opens.

Dialog box 1. SetupBACnet.exe



Dialog box 2. Entering IP address

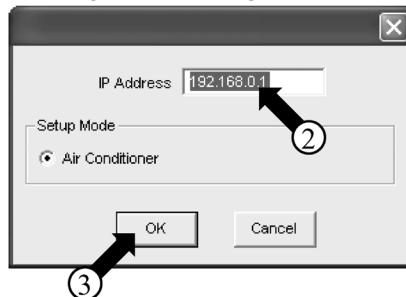

* Refer to P.24 for how to change the IP address.

Dialog box 3. Malfunction History

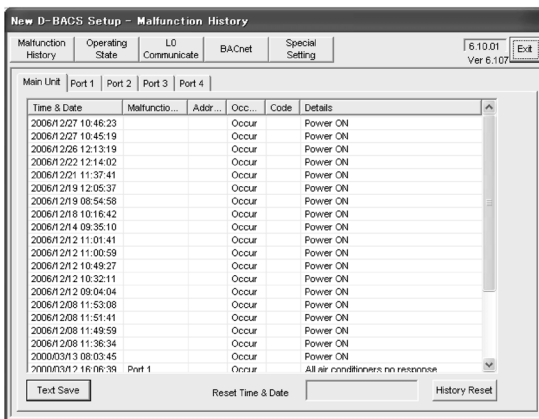

Reference: Interface for use in BACnet and trial operation PC's IP addresses

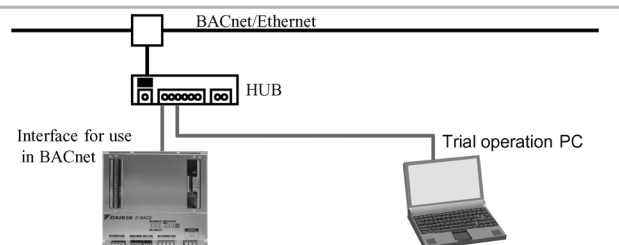

When connecting the Interface for use in BACnet and the trial operation PC via Ethernet, they cannot communicate with each other unless the following IP address settings are used.

Status	IP address of Interface for use in BACnet	Trial operation PC's IP address
Interface for use in BACnet Factory setting	192.168.0.1	192.168.0.2
IP address of Interface for use in BACnet has been changed at the site	IP address set for the Interface for use in BACnet in [6]-1 on P.11.	IP address temporarily used for the trial service operation in [6]-2 on P.11.

CB06A069E

[5] Start the trial operation program.
 (On the trial operation PC, double-click SetupBACnet.)
 Enter the IP address.

When connecting the trial operation PC and Interface for use in BACnet via RS232C]

1. Set up the modem as instructed in "3. Setting the Trial Operation PC Modem" in [Before Visiting the Site].
2. Connect the trial operation PC and RS232C-1 port of Interface for use in BACnet with the RS232C cross cable (9-pin-9-pin).



3. Double-click the dial-up shortcut () on the desktop.

4. When the dialog box below opens, click the Dial button [1]. The icon shown below right will appear on the task bar (bottom right of the screen).

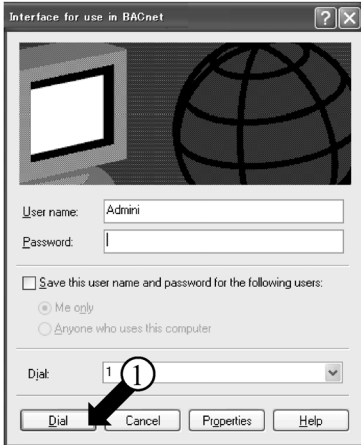

5

5. Double-click the trial operation program (SetupBACnet) icon [2]. The dialog box to enter the IP address opens.
6. Change the IP address to "192.168.3.1" and click the OK button [3]. The dialog box shown at the bottom of this page opens.

Dialog box 1. SetupBACnet.exe



Dialog box 2. Entering IP address

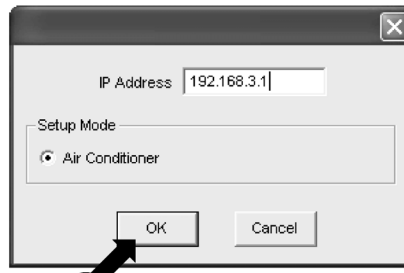

Dialog box 3. Malfunction History

Time & Date	Malfunction...	Addr...	Occ...	Code	Details
2006/12/27 10:48:23			Occur		Power ON
2006/12/27 10:45:19			Occur		Power ON
2006/12/26 12:13:19			Occur		Power ON
2006/12/22 12:14:02			Occur		Power ON
2006/12/21 11:37:41			Occur		Power ON
2006/12/19 12:05:37			Occur		Power ON
2006/12/19 08:54:58			Occur		Power ON
2006/12/18 10:16:42			Occur		Power ON
2006/12/14 09:35:10			Occur		Power ON
2006/12/12 11:01:41			Occur		Power ON
2006/12/12 11:00:59			Occur		Power ON
2006/12/12 10:49:27			Occur		Power ON
2006/12/12 10:52:11			Occur		Power ON
2006/12/12 09:04:04			Occur		Power ON
2006/12/08 11:53:08			Occur		Power ON
2006/12/08 11:51:41			Occur		Power ON
2006/12/08 11:49:59			Occur		Power ON
2006/12/08 11:36:34			Occur		Power ON
2006/03/13 08:03:45			Occur		Power ON
2006/03/13 16:06:30	Port 1		Occur		All air conditioner no response

5.6 Select the Operation Status Menu and Check the Following

[6]

Select the Operation Status menu and check the following:

- Operation status of all the air conditioners with the D III-NET concentrated addresses can be properly monitored.
- All the D III-NET concentrated devices used with the Interface for use in BACnet can be properly monitored.

Check that the D III-NET communication cabling and address assignment for the air conditioners are correctly done.

1. Check that the operation status of the air conditioners and other concentrated devices connected can be properly monitored.

1-1. Click the Operating State button [1]. Select the DIII-NET communication port of the Interface for use in BACnet to check communication in

[2]. The dialog box 1 "Operating State" opens.

1-2. Operation status of the air conditioners and concentrated devices connected to the port selected in Step 1-2 is shown in [3]. Check if other connected concentrated devices can be monitored in this dialog box.

1-3. Start and stop each air conditioner to check if the cabling and address assignment for it are correctly done.

This step needs 2 persons. One person operates the trial operation PC, while the other person checks each indoor unit to check cabling and address assignment. Start and stop each indoor unit to check whether or not it is correctly instructed and/or monitored.

You can use one of the following 2 methods:

1. Use the remote controller to start/stop the indoor unit and check if the status is reflected on the trial operation PC.
 - Check [4] in the screen below while operating the indoor unit to start/stop with the remote controller.
2. If the remote controller is not provided, start/stop the indoor unit from the trial operation PC and check if the air conditioner actually starts/stops by checking the fan rotation of the indoor unit.
 - Select the indoor unit to check in [5] and click the Aircon Control button [6]. The dialog box 2 "Air Conditioner Control" opens. Select "ON" or "OFF" in [7] and select "No Change" in [8]. Finally, click the Set button [9]. Check if the indoor unit actually starts or stops.

1-4. Repeat Steps 1-1 through 1-3 to check all the air conditioners.

Dialog box 1. Operating State

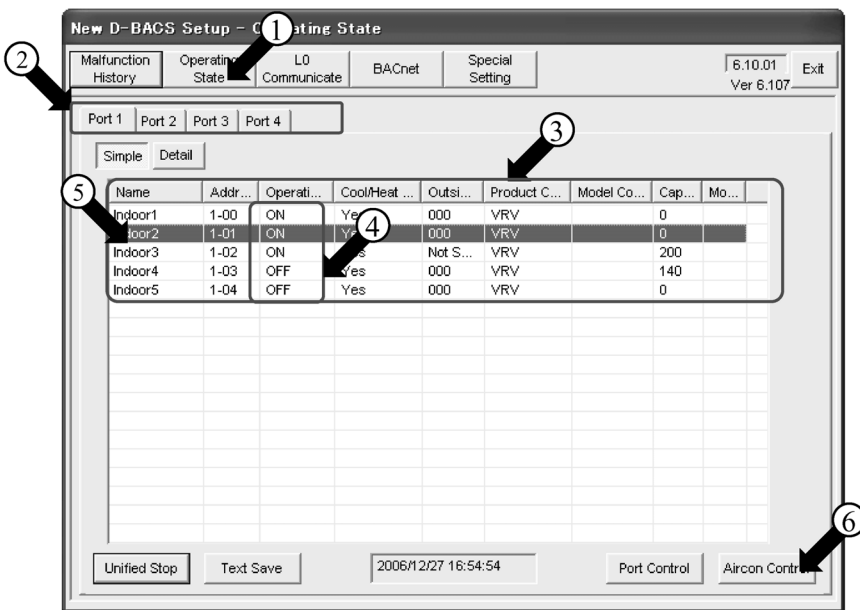

If an air conditioner cannot be started/stopped with the current address, assign the address again to that indoor unit.

Dialog box 2. Air Conditioner Control

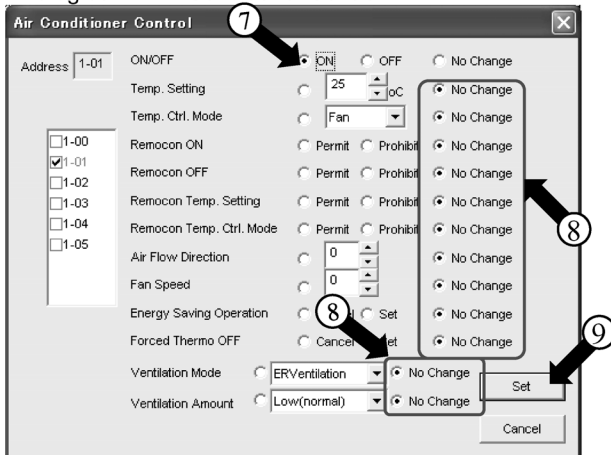

5.7 Check the Registration of Management Point Types

[7] Check the registration of management point types.
 - Check that the management point types have been registered correctly.

Check that the Management point type registered correctly for each connected device.

*Refer to P.129, 130 for necessary cases of when to register the Management point type for connected equipments.

- 1-1. Click [1] Operating State button.
 Then, select the DIII-NET port to which the air conditioners you want to check for successful registration are connected in [2].
 Then, click the Detail button [3].
 The dialog box 1 "Operating State Monitor (Detail)" opens.
- 1-2. The operating state of each air conditioner connected to the port selected in 1-1 is shown in [4].
 Check [5] Management point types to make sure that the management point types are registered correctly for each connected air conditioner.

Dialog box 1 Operating State Monitor (Detail)

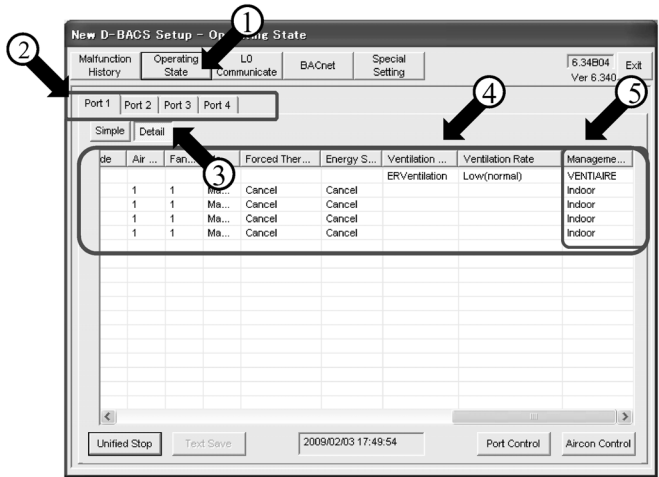

5

CB06A069E

5.8 Check the All Points from the Central Control Panel

[8]

Check the all points from the central control panel.
 • Check whether or not all the air conditioners are properly monitored/controlled from the central control panel.

Check if each air conditioner operates as instructed from the central control panel.

1. Check if the air conditioner can be properly controlled from the central control panel.

1-1. Check the items which are designated by the manufacturer to be monitored/controlled from the central control panel in the table of [5] Items monitored/controlled from the central control panel for air conditioners in "2. Obtaining Object Information". Be sure to keep records of the items checked, so that which items were checked (for the reference in case if a trouble occurs after delivery).

- Check if the air conditioner operates as instructed from the central control panel in one of the following methods:
 1. Check with the trial operation PC of Interface for use in BACnet (see below for the procedure).
 2. Check with the air conditioner's remote controller.
 3. Check with another concentrated device (e.g., central remote controller) (when other concentrated devices are used together)

The procedure to check the operation status of the air conditioner using the trial operation PC of Interface for use in BACnet is described below.

Access to the Operating State dialog box for the air conditioners as instructed on the previous page.

You can toggle the display between the simple and detailed formats by clicking the Simple button [1] or Detail button [2].

Each format lists the following items.

Dialog box 1. Simple

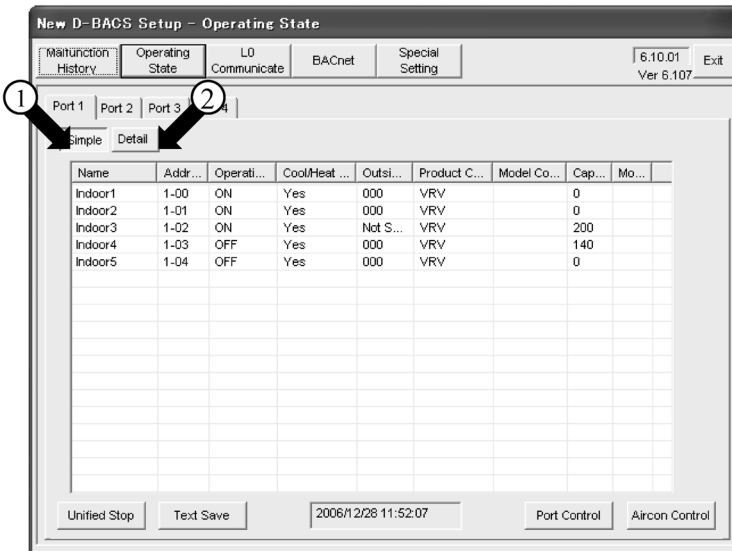

[Simple format items]

The following items are listed for each indoor unit:

- Start/stop
- Cooling/heating selection
- Outdoor unit system address
- Product code (VRV, etc.)
- Model code*
- Capacity*
- Model*

Note: Items marked with * may not be shown depending on the model.

Dialog box 2. Detail

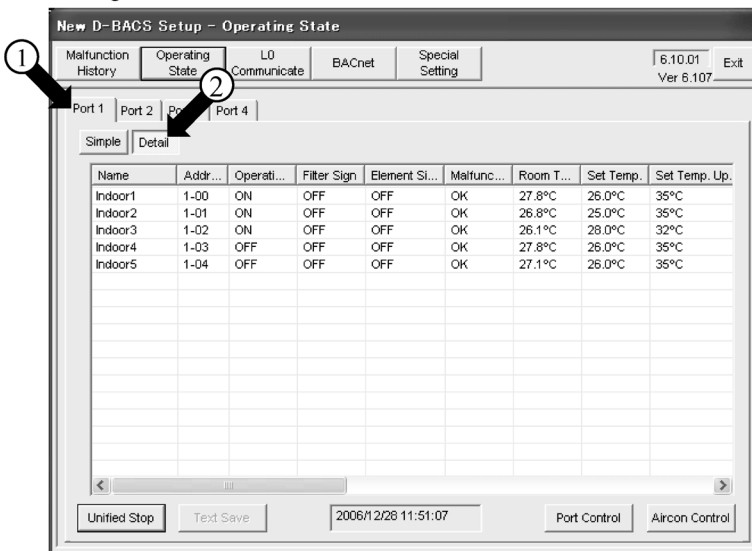

[Detailed format items]

The following items are listed for each indoor unit:

- On/Off
 - Filter sign
 - Element sign
- Malfunction code (for air conditioner failure)
- Room temperature (suction temperature)
- Set temperature
 - Upper limit of set temperature
 - Lower limit of set temperature
- Step for setting temperature
- Thermostat step
- Automatic air conditioning
- Operation mode (air conditioning mode)
- Remote controller on permit/prohibit
 - Remote controller off permit/prohibit
 - Remote controller temperature setting
 - permit/prohibit
 - Remote controller air-conditioning mode change
 - permit/prohibit
 - Airflow direction
- Fan speed
- Main/sub remote controller
- Forced thermo stop
- Energy-saving operation
 - Ventilation mode
 - Ventilation amount
 - Management point types

Note: temperature is displayed in Celsius or Fahrenheit.

[8] Check the all points from the central control panel.
 • Check whether or not all the air conditioners are properly monitored/controlled from the central control panel.

Check if operation status of the air conditioner can be properly monitored from the central control panel.

1. Check if operation status of the air conditioner can be properly monitored from the central control panel.

1-1. Check the items which are designated by the manufacturer to be monitored/controlled from the central control panel in the table of [5] Items monitored/controlled from the central control panel for air conditioners in "2. Obtaining Object Information". Be sure to keep records of the items checked, so that which items were checked (for the reference in case if a trouble occurs after delivery).

● You need to change the operation status of the air conditioner for this check. Change the operation status of the air conditioner in one of the following methods:

1. Change with the trial operation PC of Interface for use in BACnet (see below for the procedure).
2. Change with the air conditioner's remote controller.
3. Change with another concentrated device (e.g., central remote controller) (when other concentrated devices are used together)
4. The only way to check failure notification is to make an air conditioner failure to actually happen. Therefore, you need to do some work such as removing the sensor from the outdoor unit.

*: Be sure to restore the air conditioner to the original status. Note that you cannot check the filter and element signs.

The following shows how to change operation status of the air conditioner from the trial operation PC of Interface for use in BACnet.

1-1-1. Select the indoor unit to check in [1] and click the Aircon Control button [2]. The dialog box 2 "Air Conditioner Control" opens.

1-1-2. Select items to change in [3] and click the Set button [5].

(Select "No Change" for items you do not want to change in [3]. You can select multiple items at the same time.)

To apply the same change to multiple air conditioners, check them in [4]. The items shown right below can be changed from the trial operation PC.

Dialog box 1. Operating State

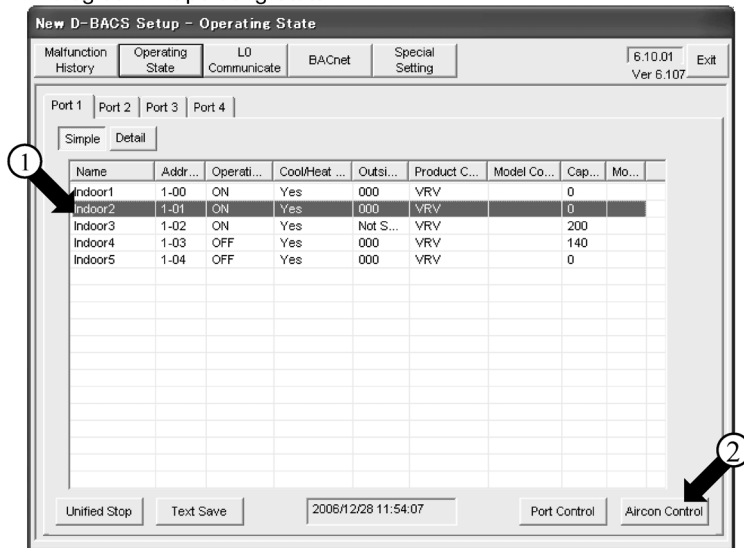

[Items which can be changed from trial operation PC]

- On/Off
- Set temperature
- Air conditioning mode
- Remote controller on permit/prohibit
- Remote controller off permit/prohibit
- Remote controller temperature setting permit/prohibit
- Remote controller air-conditioning mode change permit/prohibit
- Air flow direction
- Fan speed
- Energy-saving operation
- Forced thermo stop
- Ventilation mode
- Ventilation amount

Dialog 2. Air Conditioner Control

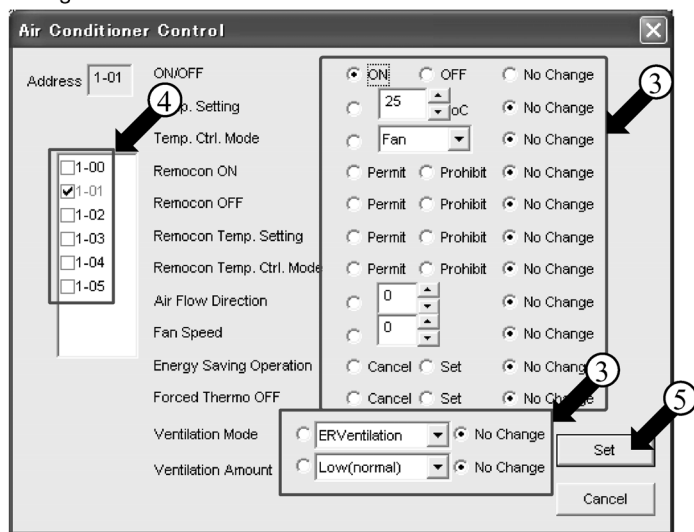

Note: temperature is displayed in Celsius or Fahrenheit.

6. Reference: Items which do not Need to be Changed from the Factory Settings

Among the items shown on the trial operation PC's screen, the following items are typically not required to be changed. The following explains the meanings of these items.

Function Config box

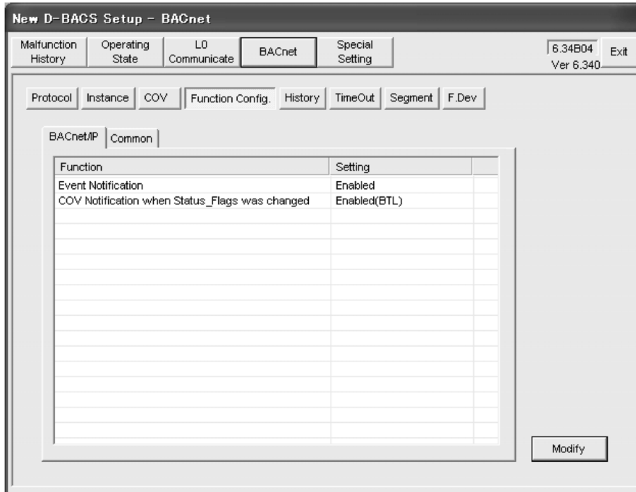

[To open this dialog box]
BACnet→Function Config

[The factory setting]

- Event Notification :
Disabled(BTL)
- COV Notification when Status_Flags was changed :
Enabled(BTL)

[About Function Config]

- Event Notification

It specifies whether to notify or not with EventNotification service about occurrence of or recovery from device abnormality, changes in filter sign, occurrence of or recovery from communication abnormality, and monitoring of upper and lower limits of actual room temperature value.

※**In order for the specification of BACnet to conform to BTL, set this function to “Disabled(BTL).”**

- COV Notification when Status_Flags was changed
It specifies whether to send COV Notification or not in response to changes in Status_Flags.

※**In order for the specification of BACnet to conform to BTL, set this function to “Enabled(BTL).”**

When it is set to “Enabled,” and it is configured to send COV (by registering with SubscribeCOV service from central control panel, or by configuring COV without registration with this trial operation tool), a large number of COV will be sent upon occurrence of communication abnormality among all air conditioning equipment. (If all objects among 256 air conditioning equipment are registered to send COV, the number will be up to about 6600). It may be a burden on the devices on receiving side or the network. If it is actually being a burden on devices or network, it is necessary to consult with the manufacturers which are connected to the network in order to reduce the number of objects configured to send COV.

CB06A069E

Function Config box

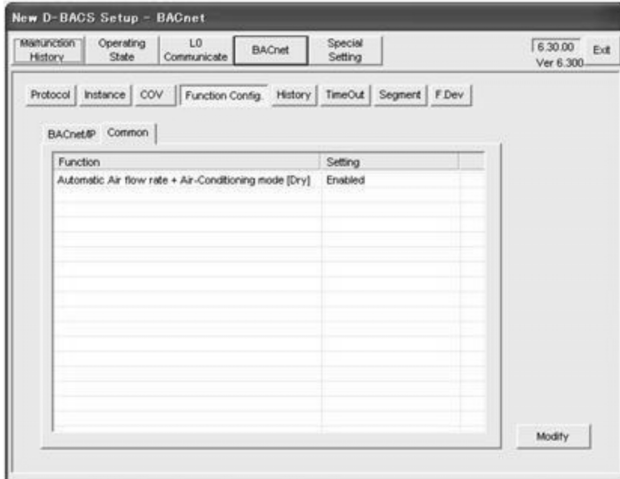

[To open this dialog box]

BACnet→Function Config→Common

[The factory setting]

- Automatic Airflow rate + Air-Conditioning mode [Dry]:Enabled

[About Automatic Airflow rate + Air-Conditioning mode [Dry]]

This function is interchangeable the software of Ver6.30 or after with the software of Ver6.20 or before.

This function can set "Enabled/Disabled" to the settings in monitoring and setting of "Middle" Airflow rate of an air-conditioning unit which have 3 levels Airflow rate, and of "Automatic" Airflow rate of an air-conditioning unit which have Automatic Airflow rate,and of "Dry" operation of an air-conditioning unit.

When the settings are set to "Enabled", the Interface for use in BACnet responds the value of the property similar to the value used in Ver6.20 or before (2 levels Airflow rate, operation mode: Cool/Heat/Fan) unless this setting never causes the unexpected error in the "Central Monitoring Device" by responding the enhanced values of the property in "Middle" and "Automatic" Airflow rate, and in "Dry" operation.

CB06A069E

[Reference: Items which do not need to be changed from the factory settings]

Among the items shown on the trial operation PC's screen, the following items are typically not required to be changed. The following explains the meanings of these items.

Timeout dialog box

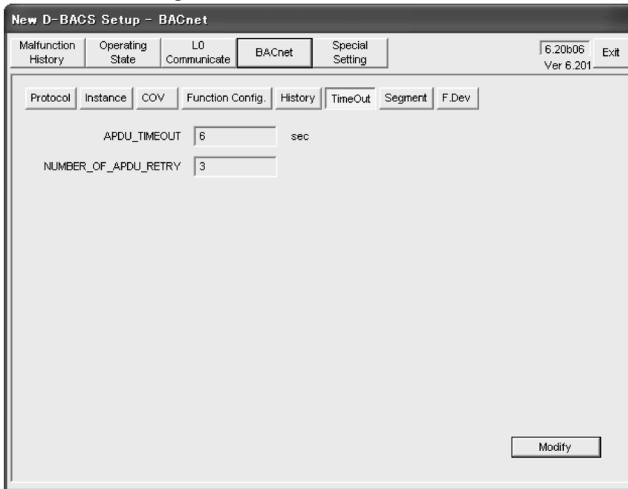

[To open this dialog box]

Select BACnet → Timeout.

[The factory setting]

- Time out period: 6 seconds
- Number of retries: 3

[About timeout]

The timeout period is the time for which the Interface for use in BACnet waits for a response message after it has sent a request message to another BACnet device (available setting range: 1 - 120 seconds).

The number of retries is the count for which the Interface for use in BACnet retries sending the same request message after timeout (available setting range: 0 - 7).

- These values need to be increased when the other party in the communication is slow. However, since it is difficult to know the other party's communication speed, change them only when the timeout period and the number of retries are specified by the manufacturer of the other party.

Segment dialog box

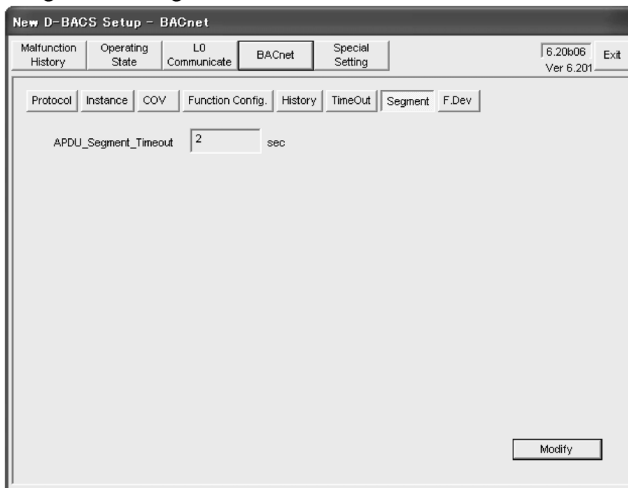

[To open this dialog box]

Select BACnet → Segment.

[The factory setting]

- Segment timeout period: 2 seconds

[About segment]

The Interface for use in BACnet support segmentation defined by the BACnet standard, and divides a message longer than one packet into multiple packets when sending and receiving it. The segment timeout period is the time for which the Interface for use in BACnet waits for a response from the other party in segmented communication (available setting range: 1 - 10 seconds).

- * Change this value only when the other BACnet device's manufacturer specifies the value because that BACnet device requires segmentation but it is slow, and so on.

CB06A069E

[Reference: Items which do not need to be changed from the factory settings]

Among the items shown on the trial operation PC's screen, the following items are typically not required to be changed. The following explains the meanings of these items.

F.Dev box

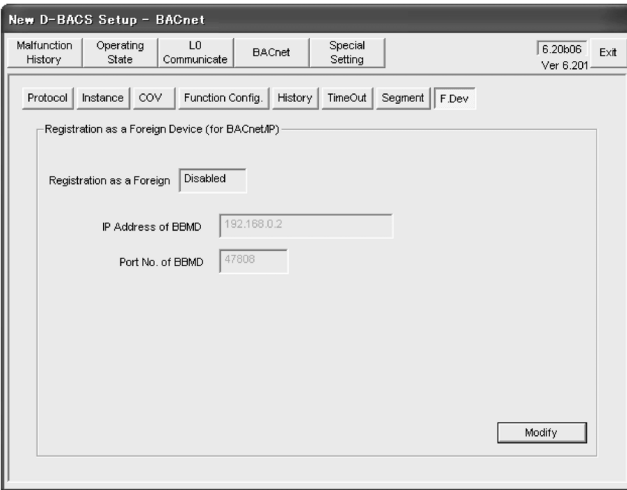

[To open this dialog box]

BACnet→F.Dev

[The factory setting]

•Registration as a Foreign : Disabled

[About Foreign Device]

If there is no BBMD(BACnet/IP Broadcast Management Device) on the same subnet as Interface for use in BACnet, it cannot receive broadcast messages from other subnets.

So the Interface for use in BACnet need to be set to behave as a "Foreign Device (see BACnet Standards Annex-J)."

By operating as a Foreign Device, it can receive broadcast messages sent from other IP subnets via BBMD.

(a) Register to BBMD as a Foreign Device (at startup of Master Station, and thereafter at a regular interval)

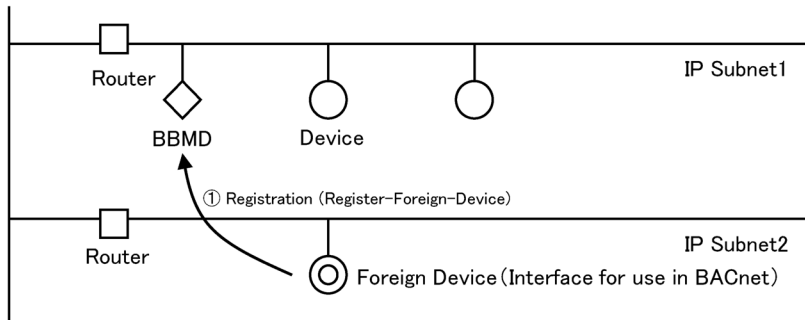

(b) Broadcast messages forwarded via BBMD

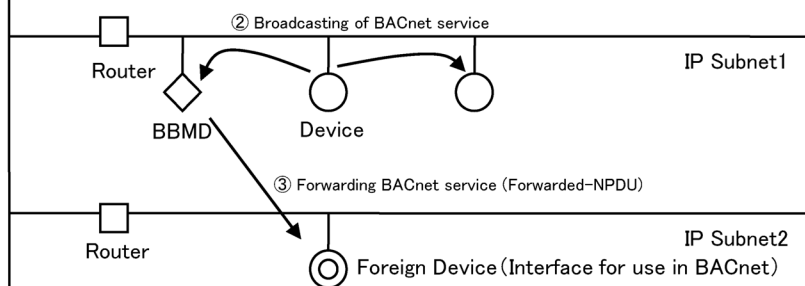

(c) Send its own broadcast messages to other devices on other subnets via BBMD

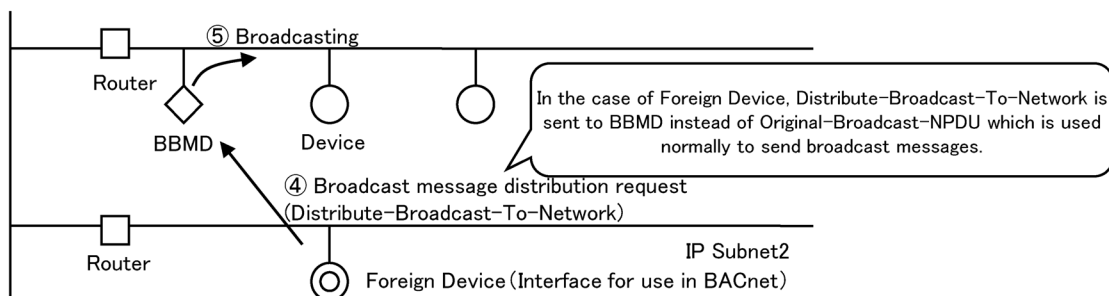

CB06A069E

[Reference: Items which do not need to be changed from the factory settings]

Among the items shown on the trial operation PC's screen, the following items are typically not required to be changed. The following explains the meanings of these items.

COS Output Mask

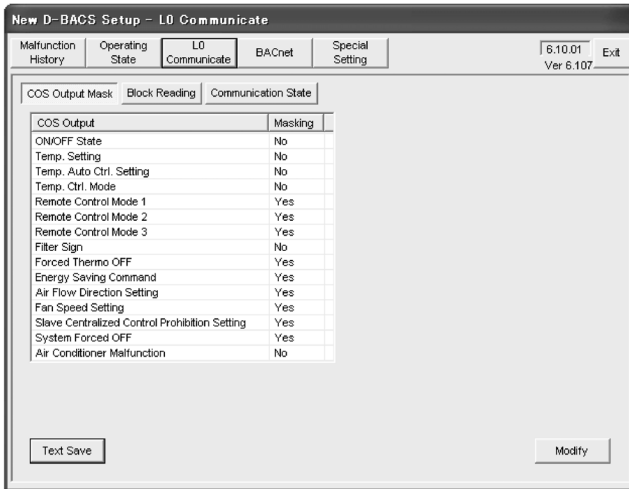

[To open this dialog box]
Select L0 Communicate → COS Output Mask.

[The factory setting]

The settings shown to the left.

[About L0 communication COS output mask]

This setting is required when RS232C communication is used rather than BACnet communication to connect to the central control panel.

You can specify, for each item, whether or not to notify the central control panel of any change of air conditioner's operation status.

Block Reading dialog box

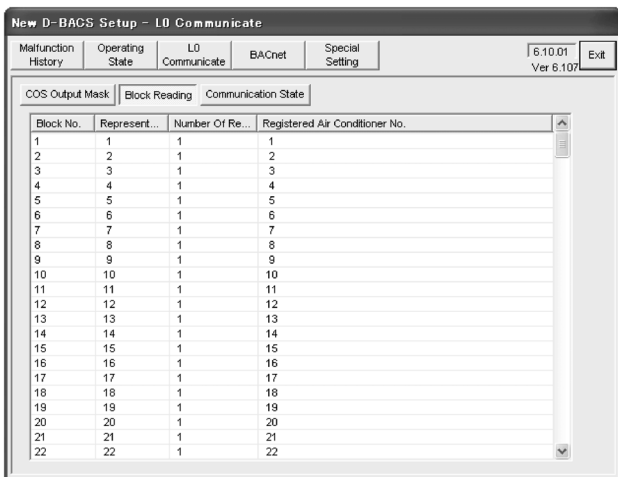

[To open this dialog box]

Select L0 Communicate → Block Reading.

[The factory setting]

This is a monitor item and therefore has not factory setting.

[About L0 communication block read]

Check this item when RS232C communication is used rather than BACnet communication to connect to the central control panel and a failure has occurred. When RS232C communication is used, the central control panel monitors or control air conditioners per block, not per DIII-NET address. You can register up to 32 groups (i.e., DIII-NET addresses) of indoor units in one block, from the central control panel to the Interface for use in BACnet. When no registration has been done, each block contains one group.

Communication State dialog box



[To open this dialog box]

Select L0 Communicate → Communication State.

[The factory setting]

This is a monitor item and therefore has not factory setting.

[About L0 communication status]

Check this item when RS232C communication is used rather than BACnet communication to connect to the central control panel and a failure has occurred. When communication between the Interface for use in BACnet and the central control panel is healthy, "Normal" is shown. If the communication is disconnected for 30 seconds or longer, "Host Down" is shown. In this case, check the connection of the RS232C communication lines and other errors.

[Reference: Items which do not need to be changed from the factory settings]

Among the items shown on the trial operation PC's screen, the following items are typically not required to be changed. The following explains the meanings of these items.

Malfunction Mask dialog box

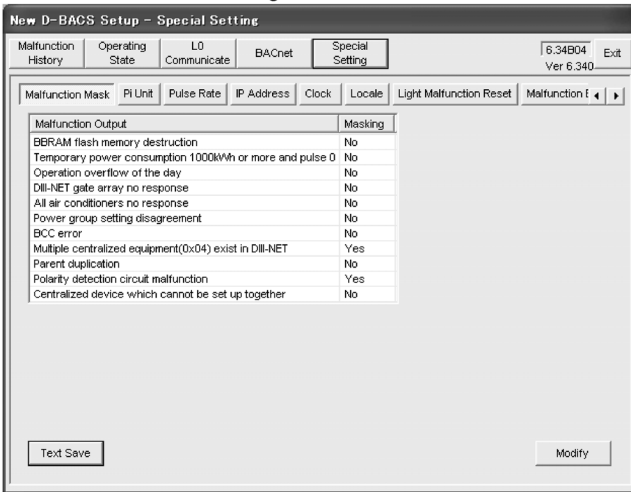

[To open this dialog box]
Select Special Setting → Malfunction Mask.

[The factory setting]
The settings shown to the left.

[About malfunction mask]
Interface for use in BACnet has a function to detect its own abnormality, turn the relay output (Do-1) of Interface for use in BACnet to ON, and let the CPU ALARM LED blink. The abnormality of its own includes the items shown on the figure left, and it is possible to mask them in order to avoid turning Do-1 to ON and CPU ALARM LED from blinking upon occurrence of each item.

This is the screen to change that mask setting. Setting is changed when location specific problem and the like occur.

Pi Unit dialog box

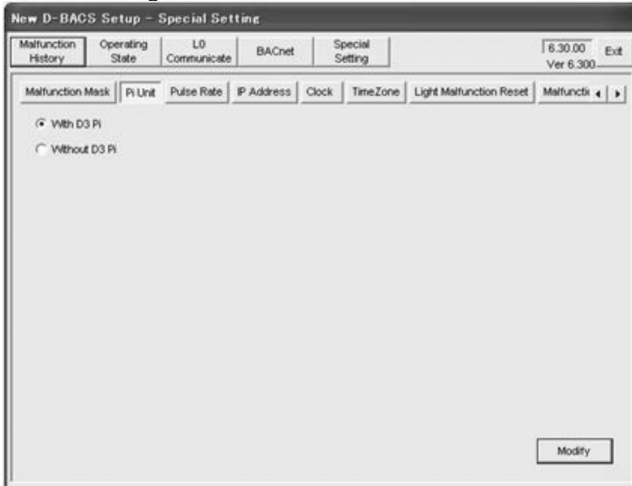

[To open this dialog box]
Select Special Setting → Pi Unit.

[The factory setting]
• No D III Pi

[Note]
This function is used only in Japan.

Pulse Rate

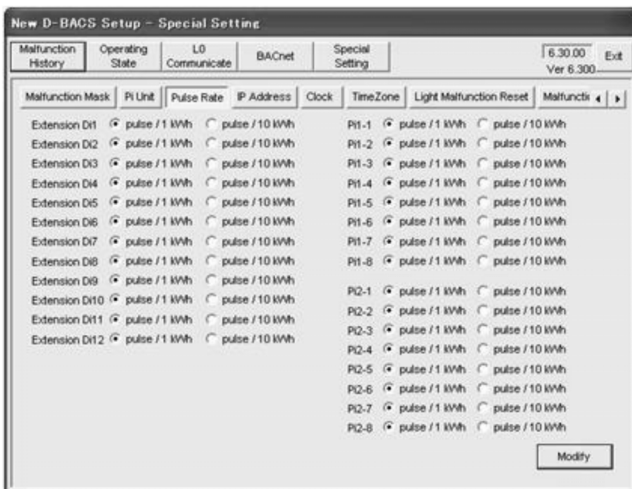

[To open this dialog box]
Select Special Setting → Plus Rate.

[The factory setting]
The settings shown to the left.

[About pulse rate]
The Interface for use in BACnet can proportionally distribute power to the air conditioners from the central control panel, by performing proportional power distribution in the trial operation. This dialog box is used to change the pulse rate of the power meter connected to each power pulse input terminal of the Interface for use in BACnet.

*: Body Di: power pulse input of Interface for use in BACnet
Extension Di: Power pulse input 1 - 12 of the optional Di board

[Reference: Items which do not need to be changed from the factory settings]

Among the items shown on the trial operation PC's screen, the following items are typically not required to be changed. The following explains the meanings of these items.

Light Malfunction Reset

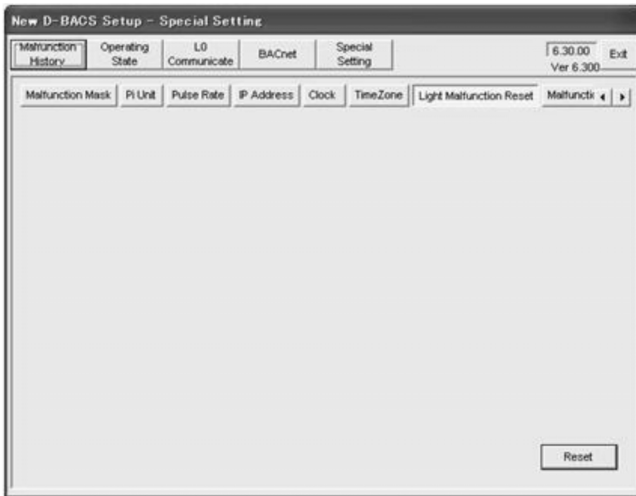

[To open this dialog box]

Select Special Setting → Light Malfunction Reset.

[The factory setting]

This only resets the device and therefore has not factory setting.

[About light malfunction reset]

The Interface for use in BACnet can detect its malfunction and turns On the Master Station III's relay output (Do-1). (Refer to the previous page for details.) **Since this malfunction greatly affects the entire system, Do-1 relay remains On once it has been activated. The light malfunction reset resets this failure output to Off. (You can also reset this output by powering the Interface for use in BACnet Off and On).**

Malfunction Error画面



[To open this dialog box]

Select Special Setting → Malfunction Error

[The factory setting]

Error type of Notification:Error OR Warning

[About Malfunction Error]

This function is a setting up function of the "Warning" signal send to the "Central Monitoring Device " due to the change of the specification of the handling of "Warning" of the air-conditioning unit. It becomes possible to notify the " Central Monitoring Device" of the crisis situation of the system that ends to "Error" by setting this item to "Error" +"Warning" beforehand.

Set it to "Error" when you exchange Interface for use in BACnet in use.

CB06A069E

7. Q & A

Question	Answer																																																																						
<p>I cannot control or monitor air conditioners from the central control panel at all. What are the possible causes?</p>	<ol style="list-style-type: none"> 1. Is the Interface for use in BACnet powered On? 2. Is the Ethernet cable connected to the Interface for use in BACnet and the central control panel? (Refer to P.98.) 3. Is the hub powered On? 4. Are the IP address, subnet mask, and default gateway address correct? 5. Is the device instance number of Interface for use in BACnet correct? (Refer to P.122) 6. Is the air conditioner's concentrated address correct? (Refer to P.136) 7. Has the point list of air conditioners been supplied to the central control panel manufacturer? (If not, contact the sales person for the object.) <p>*: When using BACnet communication to connect to the central control panel, this point list is used to configure the communication. This list should be created by the sales division for each object and supplied to the central control panel manufacturer.</p>																																																																						
<p>● Point list sample</p> <table border="1" data-bbox="194 712 951 996"> <thead> <tr> <th>Project Point Name</th> <th>Object ID</th> <th>Object Name</th> <th>Object Type</th> <th>Instance Number</th> </tr> </thead> <tbody> <tr> <td>1F Start/Stop(Setting)</td> <td>16777217</td> <td>StartStopCommand_000</td> <td>4</td> <td>1</td> </tr> <tr> <td>1F Start/Stop(Monitoring)</td> <td>12582914</td> <td>StartStopStatus_000</td> <td>3</td> <td>2</td> </tr> <tr> <td>1F Trip</td> <td>12582915</td> <td>Alarm_000</td> <td>3</td> <td>3</td> </tr> <tr> <td>1F Malfunction Code</td> <td>54525956</td> <td>MalfunctionCode_000</td> <td>13</td> <td>4</td> </tr> <tr> <td>1F Temperature Adjust</td> <td>8388618</td> <td>TempAdjust_000</td> <td>2</td> <td>10</td> </tr> <tr> <td>1F R/C Mode Setting(Start/Stop)</td> <td>20971533</td> <td>RemoteControlStart_000</td> <td>5</td> <td>13</td> </tr> <tr> <td>1F R/C Mode Setting(Air Conditioner Mode)</td> <td>20971534</td> <td>RemoteControlAirConModeSet_000</td> <td>5</td> <td>14</td> </tr> <tr> <td>1F R/C Mode Setting(Temperature Adjust)</td> <td>20971536</td> <td>RemoteControlTempAdjust_000</td> <td>5</td> <td>16</td> </tr> <tr> <td>1F Communication State</td> <td>12582932</td> <td>CommunicationStatus_000</td> <td>3</td> <td>20</td> </tr> <tr> <td>2F Start/Stop(Setting)</td> <td>16777473</td> <td>StartStopCommand_001</td> <td>4</td> <td>257</td> </tr> <tr> <td>2F Start/Stop(Monitoring)</td> <td>12583170</td> <td>StartStopStatus_001</td> <td>3</td> <td>258</td> </tr> <tr> <td>2F Trip</td> <td>12583171</td> <td>Alarm_001</td> <td>3</td> <td>259</td> </tr> <tr> <td>2F Malfunction Code</td> <td>54526212</td> <td>MalfunctionCode_001</td> <td>13</td> <td>260</td> </tr> </tbody> </table>		Project Point Name	Object ID	Object Name	Object Type	Instance Number	1F Start/Stop(Setting)	16777217	StartStopCommand_000	4	1	1F Start/Stop(Monitoring)	12582914	StartStopStatus_000	3	2	1F Trip	12582915	Alarm_000	3	3	1F Malfunction Code	54525956	MalfunctionCode_000	13	4	1F Temperature Adjust	8388618	TempAdjust_000	2	10	1F R/C Mode Setting(Start/Stop)	20971533	RemoteControlStart_000	5	13	1F R/C Mode Setting(Air Conditioner Mode)	20971534	RemoteControlAirConModeSet_000	5	14	1F R/C Mode Setting(Temperature Adjust)	20971536	RemoteControlTempAdjust_000	5	16	1F Communication State	12582932	CommunicationStatus_000	3	20	2F Start/Stop(Setting)	16777473	StartStopCommand_001	4	257	2F Start/Stop(Monitoring)	12583170	StartStopStatus_001	3	258	2F Trip	12583171	Alarm_001	3	259	2F Malfunction Code	54526212	MalfunctionCode_001	13	260
Project Point Name	Object ID	Object Name	Object Type	Instance Number																																																																			
1F Start/Stop(Setting)	16777217	StartStopCommand_000	4	1																																																																			
1F Start/Stop(Monitoring)	12582914	StartStopStatus_000	3	2																																																																			
1F Trip	12582915	Alarm_000	3	3																																																																			
1F Malfunction Code	54525956	MalfunctionCode_000	13	4																																																																			
1F Temperature Adjust	8388618	TempAdjust_000	2	10																																																																			
1F R/C Mode Setting(Start/Stop)	20971533	RemoteControlStart_000	5	13																																																																			
1F R/C Mode Setting(Air Conditioner Mode)	20971534	RemoteControlAirConModeSet_000	5	14																																																																			
1F R/C Mode Setting(Temperature Adjust)	20971536	RemoteControlTempAdjust_000	5	16																																																																			
1F Communication State	12582932	CommunicationStatus_000	3	20																																																																			
2F Start/Stop(Setting)	16777473	StartStopCommand_001	4	257																																																																			
2F Start/Stop(Monitoring)	12583170	StartStopStatus_001	3	258																																																																			
2F Trip	12583171	Alarm_001	3	259																																																																			
2F Malfunction Code	54526212	MalfunctionCode_001	13	260																																																																			
<p>I cannot control or monitor some items of the air conditioner from the central control panel. What are the possible causes?</p>	<ol style="list-style-type: none"> 1. Has the central control panel manufacturer registered correct air conditioner items (from the point list) which cannot be controlled or monitored from the central control panel? → Ask the central control panel manufacturer. 2. Has the Daikin's sales person listed correct air conditioner items (on the point list) which cannot be controlled or monitored from the central control panel? → Ask the sales person for the object. 3. Are the items in question allowed to be controlled or monitored from the central control panel? → Refer to the Engineering Data for the air conditioner, D-BACS Engineering data, or other ones. 																																																																						
<p>Status of the air conditioner is not reported to the central control panel. What are the possible causes?</p>	<p>The COV function selectively enables or disables each status items for report to the central control panel via the Interface for use in BACnet. Check with the central control panel manufacturer for the current COV settings.</p>																																																																						

Question	Answer
----------	--------

The Interface for use in BACnet and trial operation PC cannot be connected. What are the possible causes?

1. When using the RS232C cross cable
 - Has the dial-up modem of the PC been properly set up? (Refer to P.105- 114 for details.)
 - Is the correct RS232C cable type used? Is it a cross cable?
 - Is the PC's RS232C communication port functioning?
2. When using the Ethernet (LAN)
 - Is the IP address set for the PC correct? (Refer to P.117 for the correct IP address and setting procedure.)
 - Is the cable type correct?
 - [1] When connecting via the hub: Straight cable
 - [2] When connecting the Interface for use in BACnet and trial operation PC directly: Cross cable
 - Is the PC's LAN communication port functioning?
 - When using the hub, is the hub powered On?
 - Can PING be executed from the trial operation PC? (See below.)

[How to execute PING]

1. From the PC's desktop, select "Start", "Program", "Accessories", and "Command Prompt". The dialog box shown below opens.

2. Use the PC's key board, enter the IP address of Interface for use in BACnet in [1].

Ex. When IP address of Interface for use in BACnet is "150.35.20.62", enter "ping 150.35.20.62" and press the Return key.

3. If you can see information as shown in [2], the LAN connection is established. Start the trial operation program and try connection again.

If you see information as shown in [3], the LAN connection is not established for some reason. Check the PC's settings, etc. again.

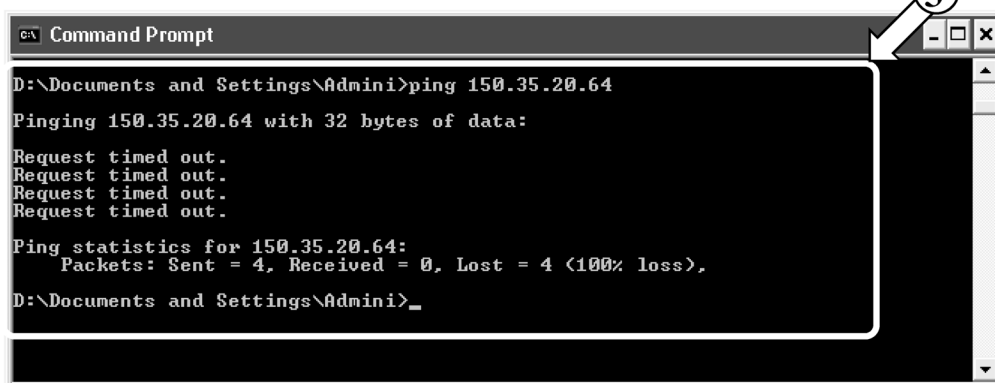
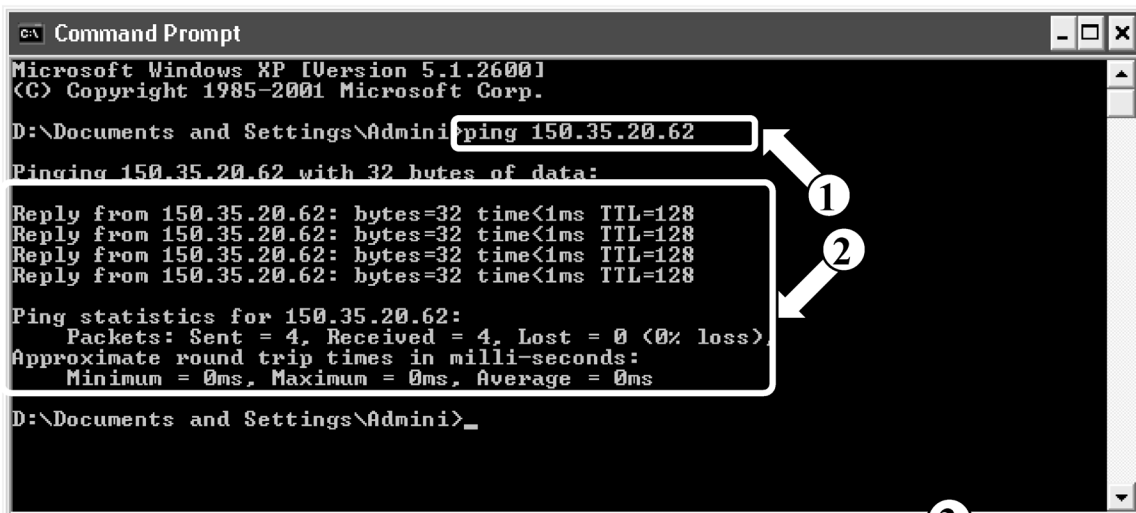

Question	Answer
<p>I must add an air conditioner after delivery. What should I do?</p>	<ol style="list-style-type: none"> 1. Create the point list for the new air conditioner and supply it to the central control panel manufacturer (by sales division). 2. Assign the address to the air conditioner at the site, and register the management point types and check the connection to the air conditioner from the trial operation PC of Interface for use in BACnet. (Refer to P.129, P.130 ,P.136, P137 for details.) 3. Check the connection between the new air conditioner and the central control panel (Refer to P.138 and P.139 for details.) 4. Make the settings of PPD again. Notice:Make it only after outputting the current charging data by the building owner,because the integrated value becomes 0 when setting it again.
<p>I must remove an air conditioner after delivery for movement. What should I do?</p>	<ol style="list-style-type: none"> 1. Inform the central control panel manufacturer of the air conditioner removed from the point list (by sales division). 2. Power the Interface for use in BACnet Off then On again to reset it. 3. Make the settings of PPD again. Notice:Make it only after outputting the current charging data by the building owner,because the integrated value becomes 0 when setting it again.

Question	Answer
My customer told that an air conditioner automatically stops. What are the possible causes?	<ol style="list-style-type: none"> 1. Is the remote controller used to stop the air conditioner? 2. Is another connected concentrated device used to stop the air conditioner? 3. Is the central control panel used to stop the air conditioner? 4. Did power failure occur at the air conditioner location? → Unless the indoor unit is configured to restart automatically after power failure (using the remote controller in the on-site mode), the air conditioner remains stopped after recovery from power failure.
My customer told that an air conditioner automatically starts. What are the possible causes?	<ol style="list-style-type: none"> 1. Is the remote controller used to start the air conditioner? 2. Is another connected concentrated device used to start the air conditioner? 3. Is the central control panel used to start the air conditioner?
My customer told that an air conditioner cannot be controlled from the central control panel. What are the possible causes?	<ol style="list-style-type: none"> 1. Are the central control panel and Interface for use in BACnet connected correctly? 2. Is the central control panel functioning? 3. Is the forced stop contact input of the Interface for use in BACnet activated? 4. Are the air conditioner which cannot be controlled and Interface for use in BACnet communicated correctly? (Is there any communication error?)
When I connect the previous trial operation(Ver. 6.3.2.0) to the software for Interface for use in BACnet main unit in Fahrenheit version (Ver. 6.33.00), what phenomenon happens?	<p>A value and unit of Temperatures displayed on the trial operation(Ver. 6.3.2.0) will be represented in Celsius.</p> <p>(Note)</p> <p>However, the value of temperatures displayed in "the BACnet history" may not be shown correctly.</p> <p>Because the value recorded in Fahrenheit with the software for the main unit (Ver. 6.33.00) is displayed in the trial operation (Ver. 6.3.2.0), the "value" in Fahrenheit will be displayed with unit "° C".</p> <p>For example, the History of changing the set temperature to "70° F" will be displayed as "70° C".</p>

CB06A069E

Question	Answer
<p>Objections were made that BACnet communication does not work. What should I check for?</p>	<ol style="list-style-type: none"> 1. Investigate the objections thoroughly. <ul style="list-style-type: none"> • What phenomenon? <ul style="list-style-type: none"> (Ex. Can the air conditioner be monitored or controlled? What is its address? What model? Who is the central control panel manufacturer? What is the central control panel model? etc.) • Determine when the communication error occurred. <ul style="list-style-type: none"> (Ex. What year, hour, and minute?) • Determine the frequency of the error. <ul style="list-style-type: none"> (Ex. Once a month) • Determine the object name and its delivery (test operation) date. <ul style="list-style-type: none"> → If you can troubleshoot the cause and determine the counter measure from the objections, you need not proceed to the following steps. 2. Check if there was any problem in the trial operation with the check record. (Refer to P.136 - 139.) 3. Check and save data related to BACnet stored in the Interface for use in BACnet from the trial operation PC. <ol style="list-style-type: none"> 3-1. Save the BACnet history data in the trial operation PC. <ol style="list-style-type: none"> 3-1-1. Connect the trial operation PC and Interface for use in BACnet, and start the trial operation program. Click the BACnet button [1] to open the following dialog box. 3-1-2. Click the History button [2] and select 10000 [3], and click the Update button [4]. 3-1-3. Click the Text Save button [5] and enter a name which can easily identify the data. (This data is used by the quality control ,design dept ., etc. of the factory to analyze the failure when it cannot be analyzed at the site.)

5

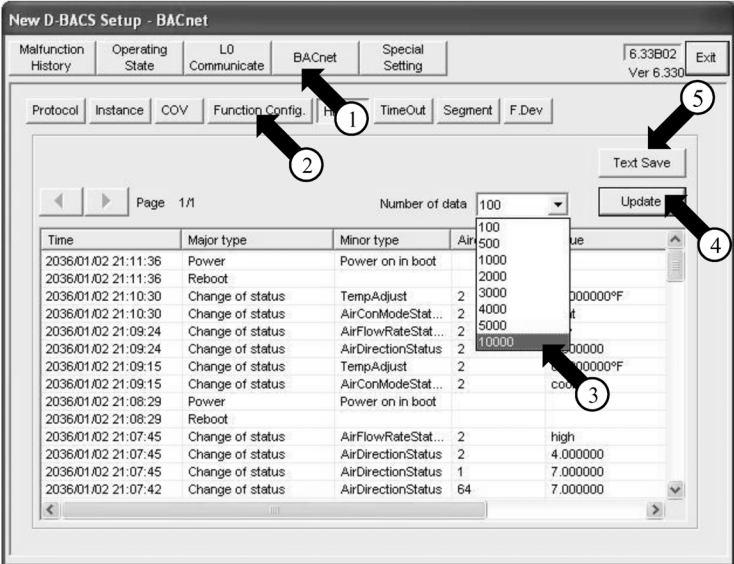

(Note) A temperature value conforms to the "Celsius/Fahrenheit setting" of the Interface for use in BACnet at the time of storing.
 A displayed unit conforms to the "Celsius/Fahrenheit setting" of the Interface for use in BACnet at the time of display.
 For this reason, if "Celsius/Fahrenheit setting" of the Interface for use in BACnet is changed after starting operation at a location, the value and the unit do not match.

For example, after switching from Celsius to Fahrenheit, a history before the change is displayed as "a Celsius temperature" with "°F".

Question	Answer
<p>Objections were made for the Interface for use in BACnet from the site after delivery. What information or data should I correct?</p>	<ol style="list-style-type: none"> 1. Investigate the objections thoroughly. <ul style="list-style-type: none"> · What phenomenon? <ul style="list-style-type: none"> (Ex. Can the air conditioner monitored or controlled? What is its address? What model? Who is the central control panel manufacturer? What is the central control panel model? etc.) · Determine when the communication error occurred. <ul style="list-style-type: none"> (Ex. What year, month, and day?) · Determine the frequency of the error. <ul style="list-style-type: none"> (Ex. Once a month) · Determine the object name and its delivery date. <ul style="list-style-type: none"> → If you can troubleshoot the cause and determine the counter measure from the objections, you need not proceed to the following steps. 2. Check and save data stored in the Interface for use in BACnet from the trial operation PC. <ol style="list-style-type: none"> 2-1. Save the BACnet malfunction history data in the trial operation PC. <ol style="list-style-type: none"> 2-1-1. Connect the trial operation PC and Interface for use in BACnet, and start the trial operation program. The following dialog box opens. 2-1-2. This dialog box displays history including air conditioner failures and power ON/OFF status. Check the history and search for data related to the objections. 2-1-3. Save the malfunction history data in the trial operation PC. <ul style="list-style-type: none"> Click the Text Save button [1] and enter a name which can design dept.,etc. easily identify the data. (This data is used by the quality control division etc. of the factory to analyze the failure when it cannot be analyzed at the site.) The History Reset button [2] erases the malfunction history data stored in the Interface for use in BACnet. However, because you usually need not erase the history, do not click this button. 2-1-4. Check and save (if necessary) detailed malfunction history for each D3-NET communication port in [3]. <ul style="list-style-type: none"> (Note 1): The malfunction history contains the latest 40 occurrences for each category in [3] (main unit and ports 1 through 4). (Note 2): To save the malfunction history, click the Text Save button [1] for each category in [3] (main unit and ports 1 through 4). 3. Save the BACnet history in the trial operation PC as instructed in Step 3 on the previous page.

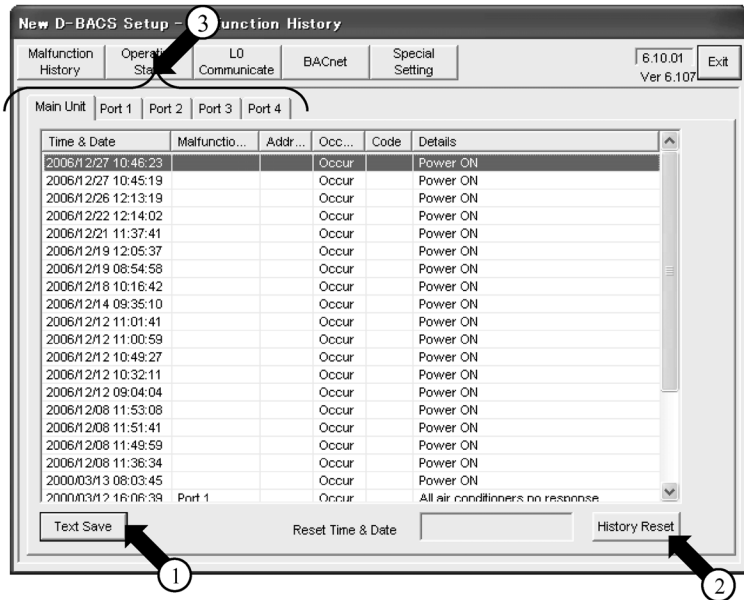

Part 6

Test Run Manual (PPD)

1. Test Run Procedures	156
2. Connection between Service PC and Interface for use in BACnet® ...	157
2.1 Wiring	157
2.2 Setting of IP Address (Windows 2000).....	158
3. Setting of Pulse Rate (Using SetupBACnet®.exe)	160
4. Startup of PPD Test Run Tools (Using SetupPPD.exe).....	164
5. Initializing	165
6. Setting of Ports.....	166
7. Hardware Setting	167
7.1 Automatic Setting	168
7.2 Manual Setting	169
8. Power Distribution Group Setting.....	170
8.1 Power Distribution Group Editing	171
9. Confirmation of Operation	172
9.1 Detailed Explanation for Confirmation Window	173
9.2 Confirmation Window, Normal Model.....	174
9.3 Confirmation of the Type of Wattmeter	178
9.4 Confirmation of Pulse Input	179
9.5 Confirmation of Integrated Values, Normal Model	180
10. Error Messages	182

[Introduction]

A test run is required before using the following PPD function of the Interface for use in BACnet.

- Sending the accumulated power data to the central control panel (HIM) via BACnet communication.

Setting of the pulse rate with the test run tool, SetupBACnet.exe and setting of the power distribution group with PPD test run tool, SetupPPD.exe using the service PC are required for the test run.

- * The test run shall be carried out with the Interface for use in BACnet (DMS502B51) being connected to the service PC with an Ethernet cable.

The Ethernet connection is the only possible way to connect between the Interface for use in BACnet and the service PC.

- * **The test run tool ver2.100 or later (distributed by FD06A219) shall be used for the test run of the PPD function of the Interface for use in BACnet.**

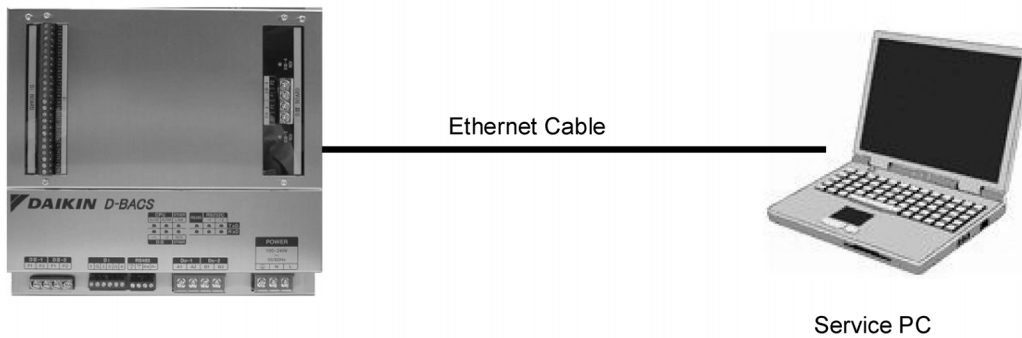

Interface for use in BACnet Body

- * **NOTE :** Make sure that the service PC meets following requirements for the PC to be used for the test run.

CPU	Pentium III 800MHz or higher
OS	Windows XP SP3
Memory	256 MB or higher
Hard disk space free	Minimum 100 MB or higher
Network	10BASE-T or 100BASE-TX

CB06A070B

[Precautions]

1. Be sure that **the backup battery switch on the Interface for use in BACnet is turned on** before carrying out the test run of the PPD function.
 - If the backup battery switch is turned off, the distribution results **will be erased on the occurrence of power failure**.
 As for the way of setting, refer to the installation manual for the Interface for use in BACnet.

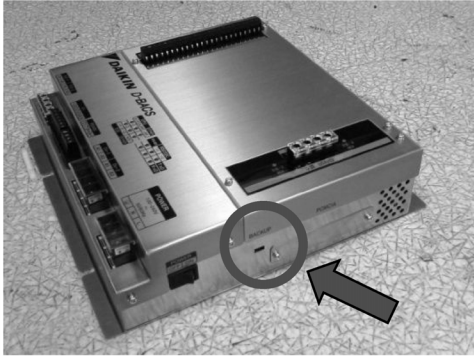

Fig. 1 Location of the switch

Fig. 2 Location of the switch

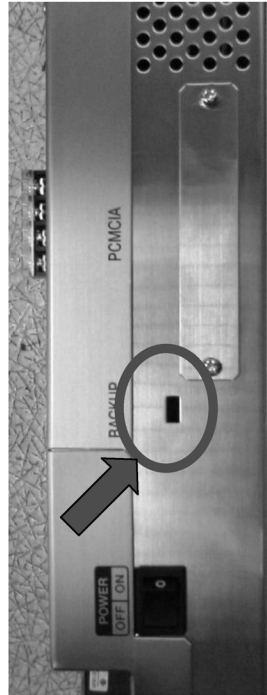
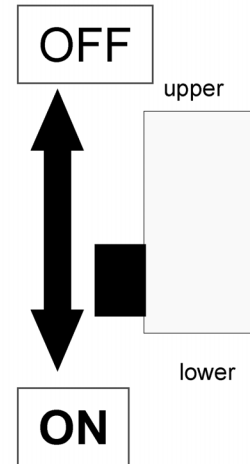



Fig. 3 Battery switch



2. Location of the switch is shown by  in the above figures. Use a precision screw driver with a narrow end to switch it. Inside of the unit at the switch part is shown in Fig. 3. When the knob is moved to upward, the switch is turned off and **downward to on**.

CB06A070B

1. Test Run Procedures

Test run procedures for the Interface for use in BACnet are as follows.

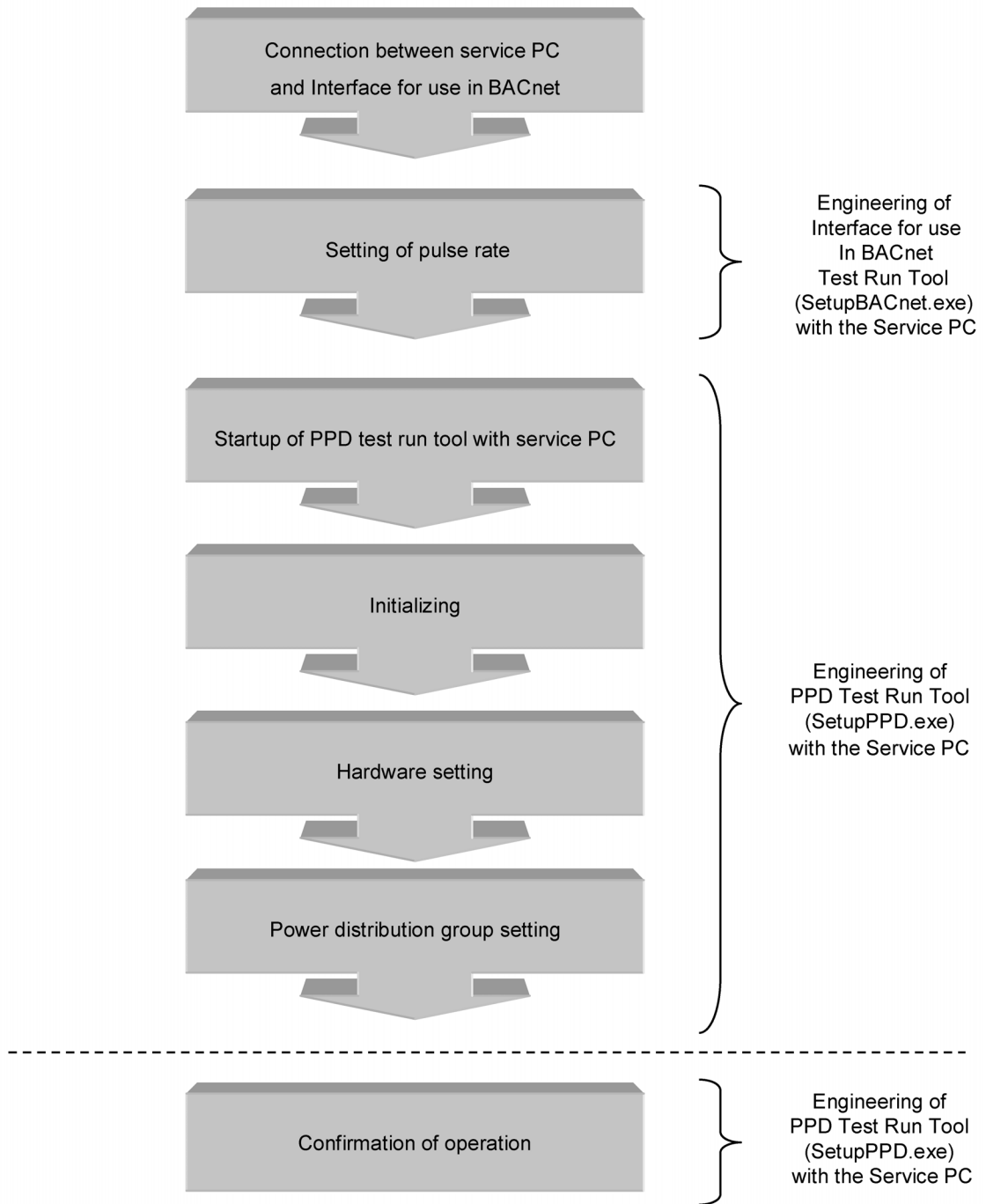

CB06A070B

2. Connection between Service PC and Interface for use in BACnet®

The test run shall be carried out with the service PC connected to the Interface for use in BACnet with a network connection using an Ethernet cable.

* There are 2 kinds of Ethernet connecting cables between the service PC and the Interface for use in BACnet, which are straight cable and a cross cable. Connect the service PC and the Interface for use in BACnet referring to following wiring diagrams.

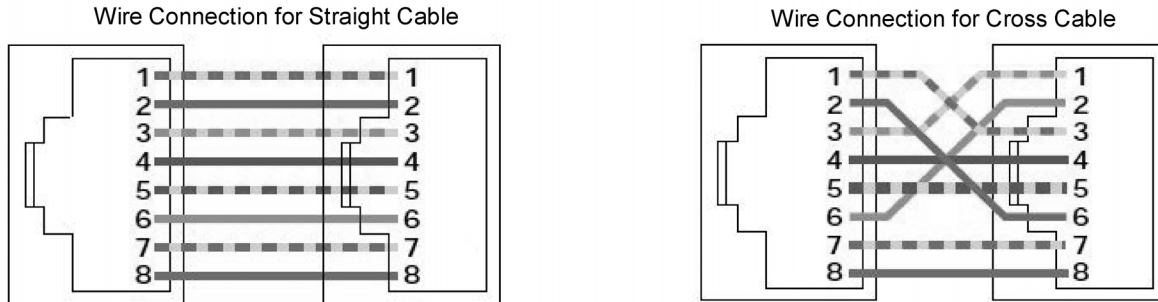

2.1 Wiring

1. In case of connecting the service PC and the Interface for use in BACnet one to one,

A cross cable of 10BASE-T or 100BASE-TX shall be used as an Ethernet cable.

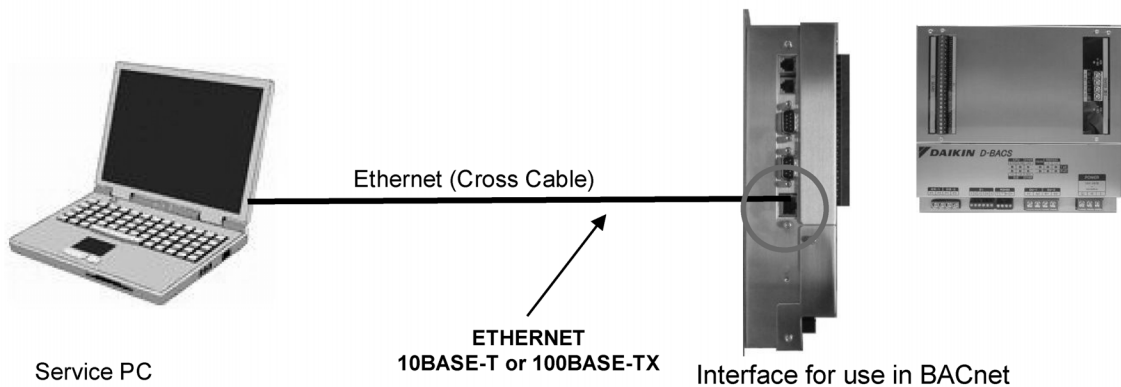

6

2. In case of connecting the service PC and the Interface for use in BACnet through a hub,

A straight cable of 10BASE-T or 100BASE-TX shall be used as an Ethernet cable.

* Setting can be made during a BACnet communication.

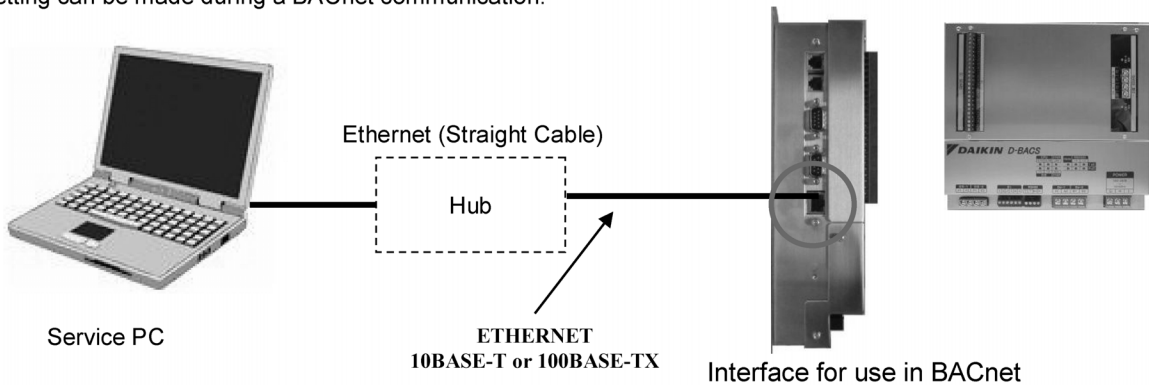

CB06A070B

2.2 Setting of IP Address (Windows 2000)

1. Setting up the IP address of the PC. First go into **Control Panel** then **Network and Dial-up Connection**.



2. Then click on **Local Area Connection** and select **Properties**.

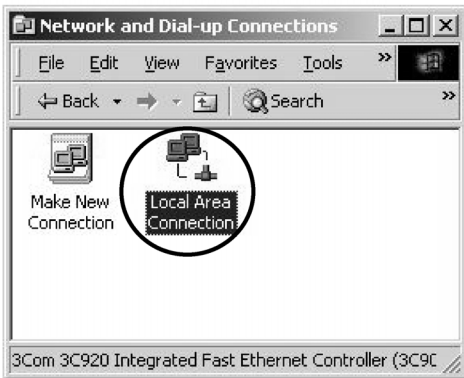

3. From here select **Internet Protocol (TCP/IP)** and select properties or just double click on it.

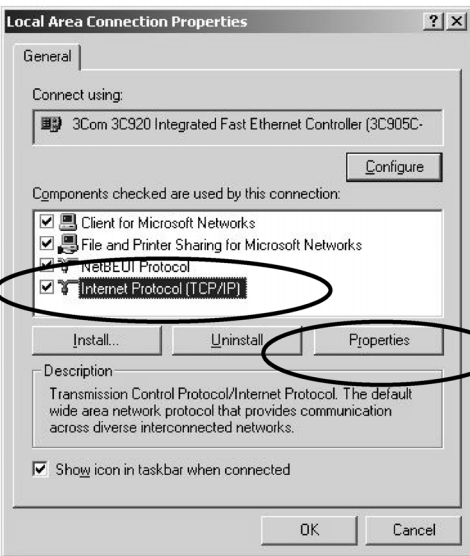

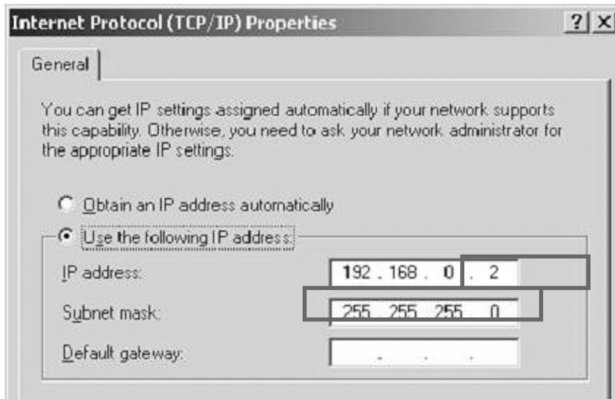

5. Set IP address and Subnet mask.

* : **Here, either one of the following steps (1) or (2) shall be taken depending on the IP address status of the Interface for use in BACnet for setting the IP address of the test run PC.**

(1) In case that the IP address of the Interface for use in BACnet

has not been changed from the one originally set at the manufacturer's work, set with the following addresses.

- IP address : 192.168.0.2
- Subnet mask : 255.255.255.0
- Default gateway address: 192.168.0.100

(2) In case that the IP address of the Interface for use in BACnet

has been changed from the one originally set at the manufacturer's work with some reasons, set with the IP address temporarily allowed by the HIM for the service test run.

(Refer to CB06A069 P11 [6] IPv4 address, Table 2)

6. Make sure the the settings are made correctly and press "OK" to close dialogs "Internet Protocol (TCP/IP) Properties" and "Local Area Connection Properties".

CB06A070B

3. Setting of Pulse Rate (Using SetupBACnet®.exe)

- * Setting of the pulse rate shall be made with the Interface for use in BACnet test run tool (SetupBACnet.exe) but not with PPD test run tool (SetupPPD.exe).
- * As restart of the Interface for use in BACnet is **required for setting** of the pulse rate, check with the manufacturer of the HIM before conducting the setting.



1. Double click "SetupBACnet.exe" to change the pulse rate from the Interface for use in BACnet test run tool.
2. The dialog for IP address input will appear. Input the IP address of the Interface for use in BACnet at the IP Address field and click "OK"

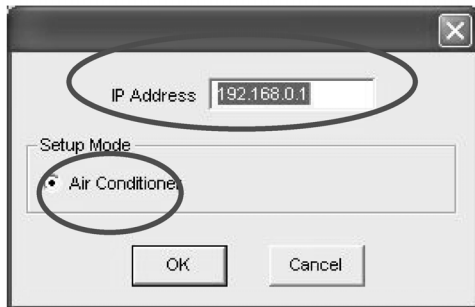

* **Either one of the following IP addresses (1) or (2) shall be input depending on the IP address status of the Interface for use in BACnet.**

(1) In case that the IP address of the Interface for use in BACnet has not been changed from the one originally set at the manufacturer's work, input the following IP address
 · IP address : 192.168.0.1

(2) In case that the IP address of the Interface for use in BACnet has been changed from the one originally set at the manufacturer's work with some reasons, input the IP address specified by the central control panel.
 (Refer to CB06A069 P11 [6]IPv4 address, Table 1)

3. Malfunction History window will appear. Click "Special Setting".

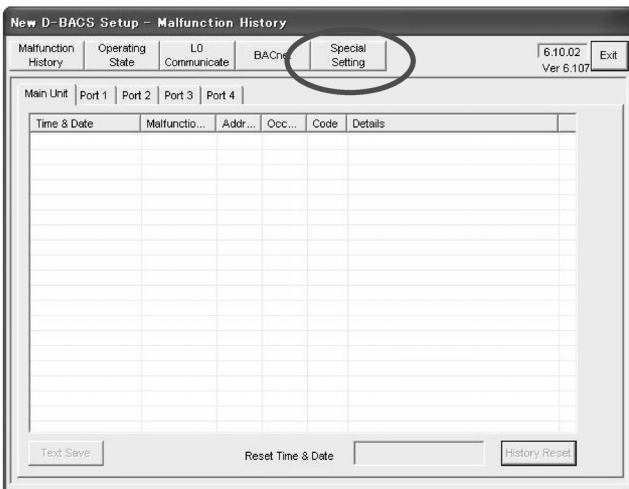

4. Special Setting window will appear. Click "Pulse Rate".

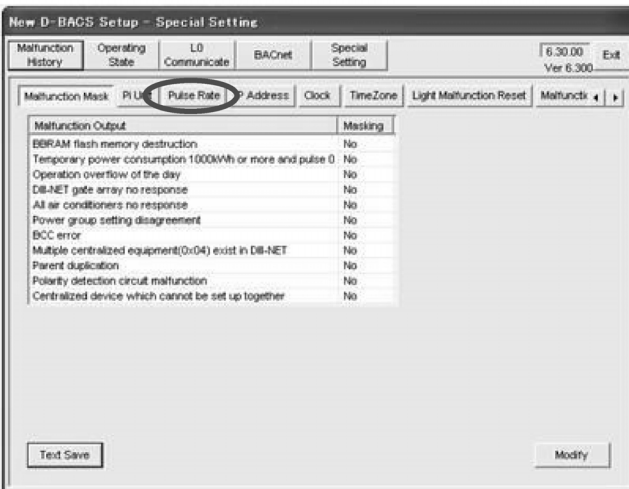

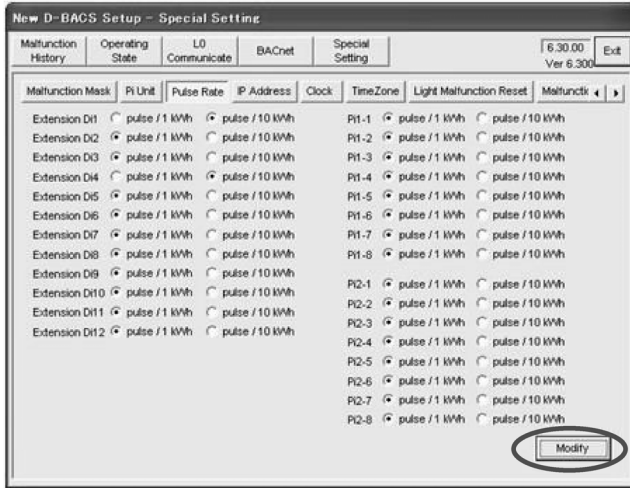

5. Pulse rates will be shown on the Special Setting window. Click "Modify".

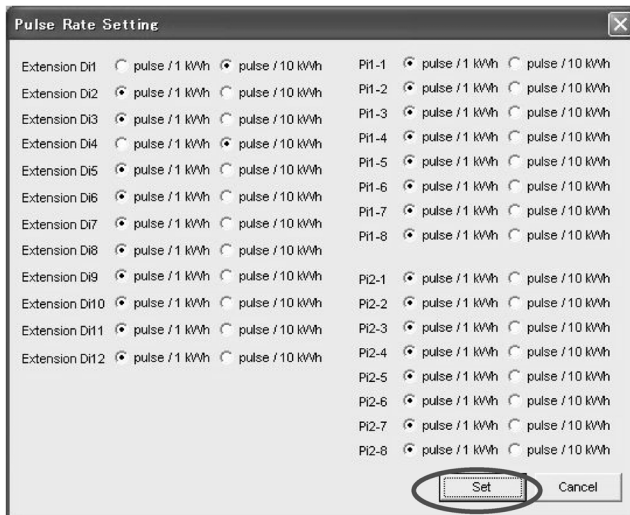

6. Pulse Rate Setting window will appear. If some pulse rate change is required, change the pulse rate of the port needs to be changed. (Select either 1kWh or 10kWh.) When all the changes are done, click "Set".



7. Confirmation dialog will appear. Click "OK".

6

CB06A070B

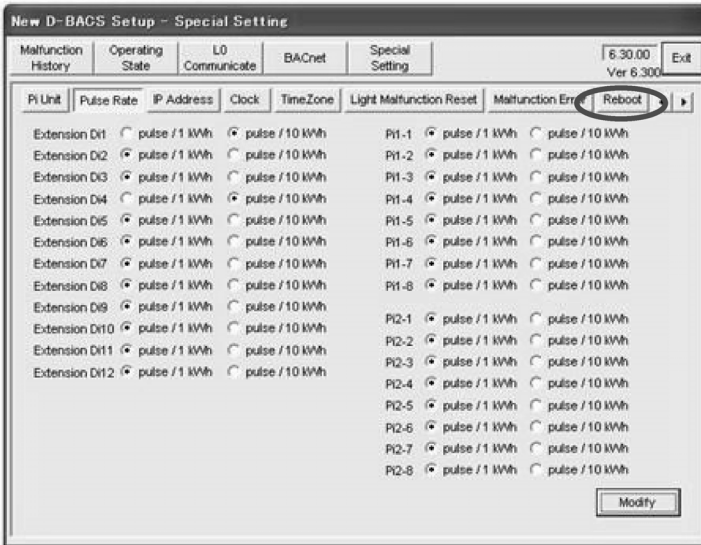

8. Pulse rates will be shown on the Special Setting window.

Check to see if the pulse rate change has been made correctly for the selected ports.

If the change is confirmed, click "Reboot".

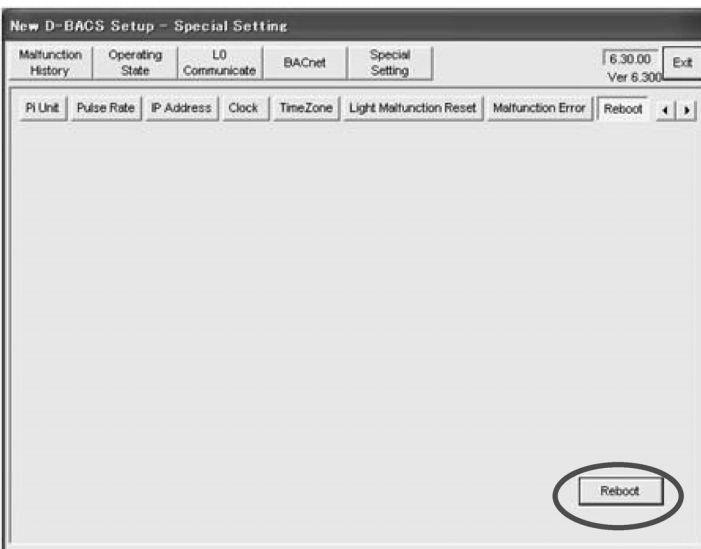

9. "Reboot" button will appear on Special Setting window. Click it to restart the system.

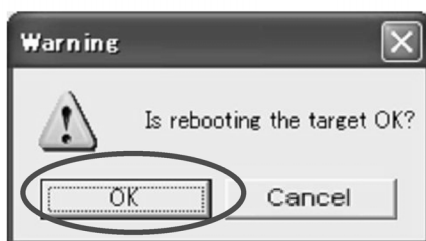

10. Warning dialog will appear. Click "OK".

CB06A070B

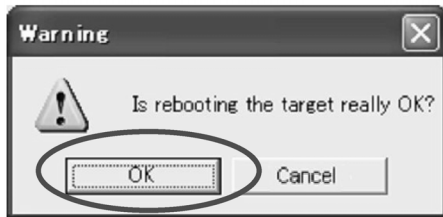

11. Warning dialog will appear again.
Click "OK".

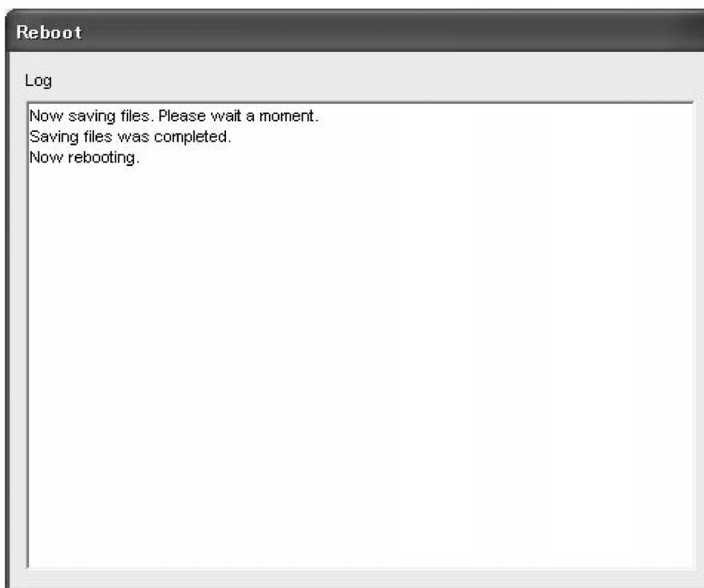

12. Progress of restart will be shown.
The restart shall be made automatically.

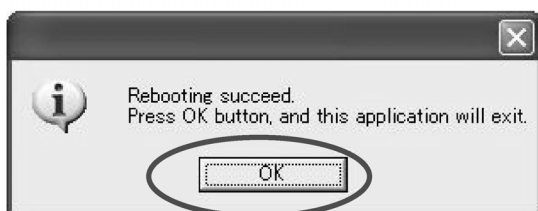

13. Confirmation dialog will appear.
Click "OK".

The Interface for use in BACnet test run tool finishes here.
If the Interface for use in BACnet test run tool is required to be used again, double click "SetupBACnet.exe" as shown in step 1.

CB06A070B

4. Startup of PPD Test Run Tools (Using SetupPPD.exe)

1. Startup the shortcut to SetupPPD.exe with the service PC.



2. IP address input dialog will appear.

3. Input the IP address of Interface for use in BACnet.

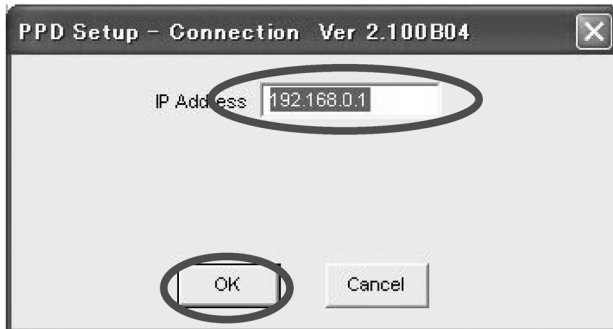

* Either one of the following IP addresses (1) or (2) shall be input depending on the IP address status of the Interface for use in BACnet.

- (1) In case that the IP address of the Interface for use in BACnet has not been changed from the one originally set at the manufacturer's work, input the following IP address
 - IP address : 192.168.0.1
- (2) In case that the IP address of the Interface for use in BACnet has been changed from the one originally set at the manufacturer's work with some reasons, input the IP address specified by the HIM.
(Refer to CB06A069 P11 [6] IPv4 address, Table 1)

4. Initialize window will appear.

(Note) Make sure that PPD Method in this window is "Air-condition Load".

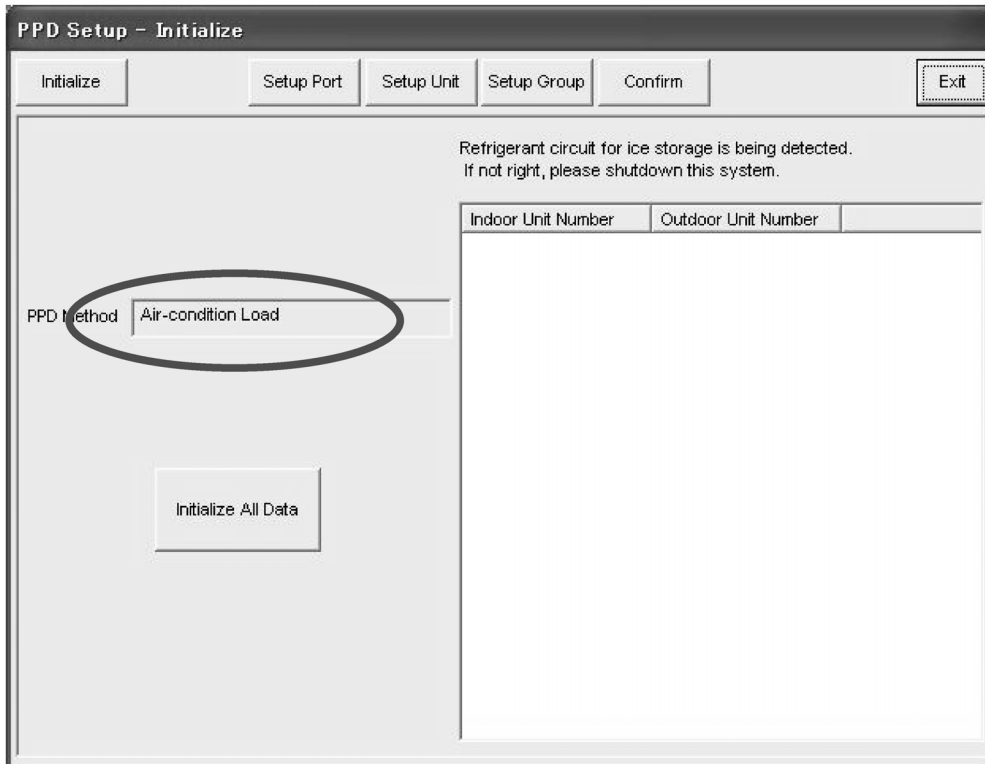

CB06A070B

5. Initializing

1. When the connection between the Master Station III and the service PC has been successfully made, following window will appear on the screen. Pressing the "Initialize" button on the upper left corner allows you to get to this window anytime.
2. When the setting is made for the first time, press the "Initialize" button **to initialize all the set values and calculation data**. Do not conduct any other operation until you get the confirmation dialog showing the initializing is made successfully.

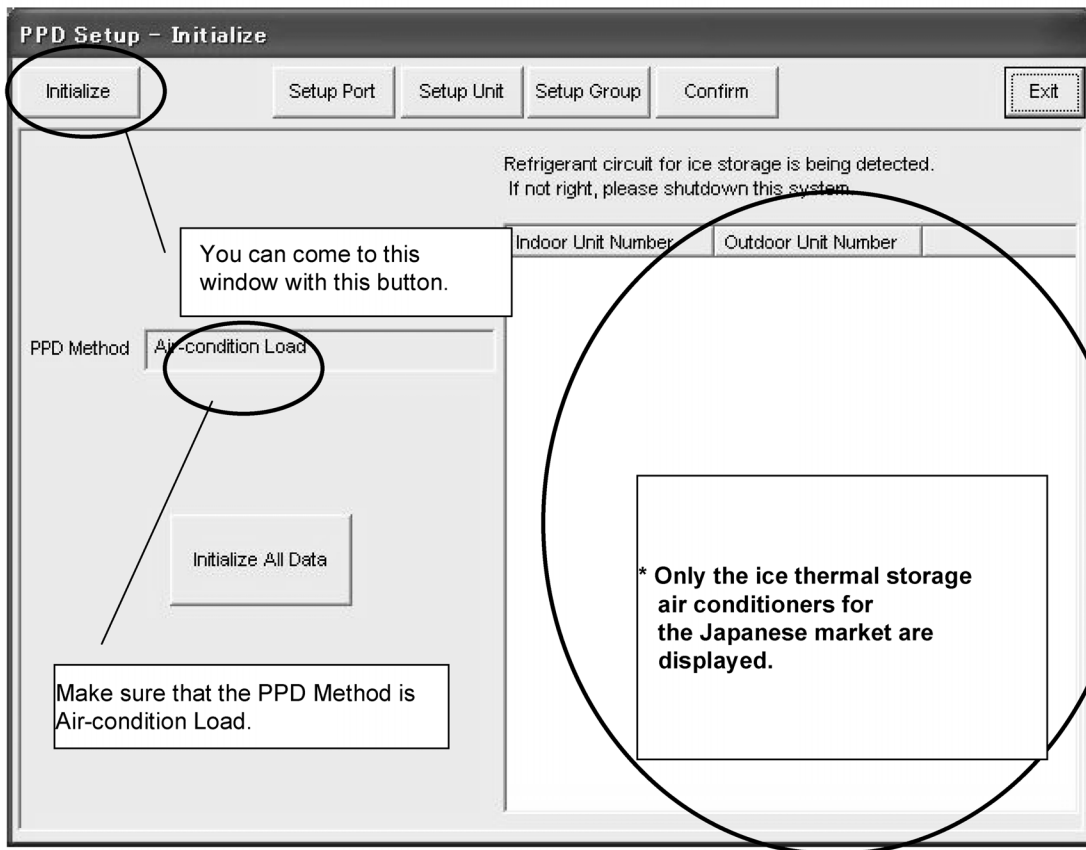

6

CB06A070B

6. Setting of Ports

1. Press "Setup Port" button.

The settings for the ports set in the step 3.

Make sure that the pulse rates for each port are set correctly.

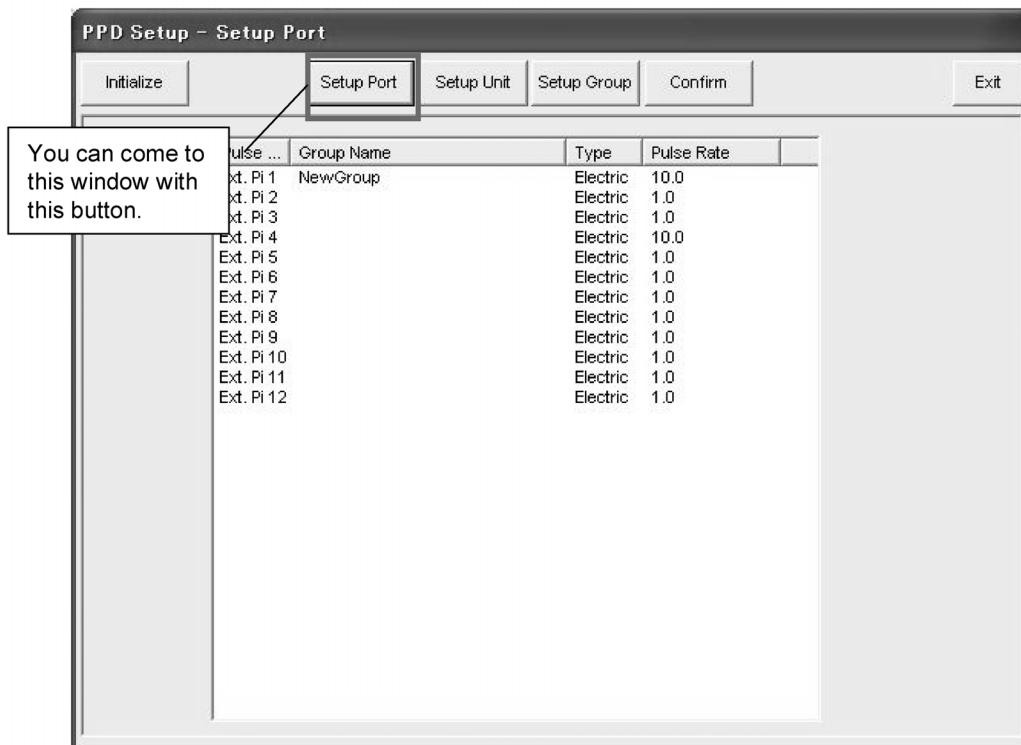

CB06A070B

7. Hardware Setting

1. Press the "Setup Unit" button to show the window shown below. The machines that belong to the power distribution groups for which proportional distribution is being calculated will be shown in red letters. The settings for the power distribution group cannot be changed when it is being calculated.
2. Press the "Auto Setup" button to start the automatic setting (*1) for the hardware. The model name for the air-conditioner that is first detected will be shown. Then press the "Setting Start" button if there are no problems.
3. When the hardware calculation conditions are required to change (default settings are "Power Proportional Distribution", "include power during stop", "include power of Heater" and "include power of Fan"), press the "Modify Setup" button and make settings manually using the Manual Setting function (*2).
4. For the hardware that cannot be set with the Automatic Setting function and the Heat Reclaim Ventilator type machines, press "Modify Setup" and make settings manually (*3).

(Note)

* 1 Automatic Setting : The installed air-conditioners shall be automatically recognized and the coefficients corresponding to each model shall be set.

* 2 Manual Setting : The coefficients and calculation conditions are set manually on an individual basis.

* 3 An automatic setting with a load distribution method cannot be made for the floor standing duct type machines. For the floor standing duct type air conditioners, the fan size shall be set when they are installed. Set the coefficient corresponding to the fan size set at site. (Refer to Appendix A)

The screenshot shows the "PPD Setup - Setup Unit" window. At the top, there are buttons: "Initialize", "Setup Port", "Setup Unit" (circled), "Setup Group", "Confirm", and "Exit". Below these are tabs for "D3port #1", "D3port #2", "D3port #3", and "D3port #4". The main area contains a table with columns: "No.", "Group Name", "Model Name", "Comment", "Calc. Ty...", "PPD", "+St...", and "+H...". The table lists units 1-1-00 to 1-2-07. On the right side, there are buttons: "Modify Setup" (circled), "Copy", "Paste", "Clear", and "Auto Setup" (circled). A legend at the bottom right indicates that "*" means "Performed" and "-" means "Not performed".

Callouts in the image:

- "You can come to this window with this button." (points to the Setup Unit button)
- "To make manual settings" (points to the Modify Setup button)
- "To copy, paste and delete contents of settings (various coefficients)" (points to the Copy, Paste, and Clear buttons)
- "To make automatic settings" (points to the Auto Setup button)

7.1 Automatic Setting

1. When the "Automatic Setting" button in the "Hardware Setting" dialog box is clicked, select the power supply specification.
2. When the "Select" button is clicked, the installed air-conditioners are automatically recognized (*) and a search for data on the pertinent models is conducted. If data exists on a model, then the model name will be shown in the dialog box below.
3. When setting, the conditions can all be set at once after clicking the "Conditions Setting" button.
4. Clicking the "Begin Setup" button sets the coefficient values (within the model data) and specified calculation conditions for all the detected air-conditioners.

(Note)

* Automatic Model Recognition

Already set air-conditioners are not targeted in the automatic setting, so it is necessary to either completely delete all prior settings by formatting or delete the data for only those models necessary with the "Clear" button.

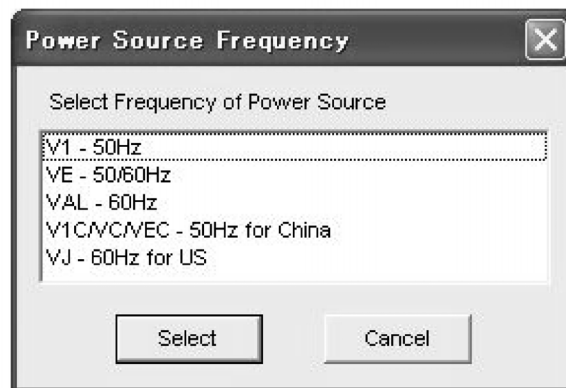

Only existing data for pertinent models is shown.

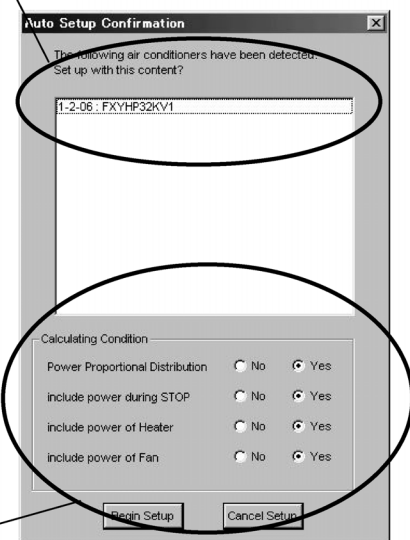

Set all default settings to "Yes" when conducting all the condition settings at once.

CB06A070B

7.2 Manual Setting

1. Press "Modify Setup" button in the "Setup Unit" window. Then the window shown below will appear.
2. In order to manually input all data, input the appropriate values for the "Calculation Type (*1)", "Comment", "Calculating Condition" and "Coefficient Setup" ("Model Name" cannot be manually input).
3. In order to use the coefficients in the model data file, press the "Consult Database" button and select the appropriate coefficient from the displayed list.
4. In order to revise only a portion of the existing model data at source, press the "Modify Coefficient" button and change the values in the "Coefficient Setup (*2)".
5. The "Calculating Condition" can be changed at any time.

(Note)

- *1 Calculation Type : There are 3 methods for calculation of power consumption, "Normal (VRV type)", "Heat Reclaim Ventilator Type" and "Adaptor Type". "Normal" is used for hardware for which power consumption is calculated according to proportional distribution, while the other methods are used for hardware for which power consumption is calculated according to operation time.
- *2 Coefficient Setup : All coefficients can be set with "Normal", "Fan Rated Power Consumption" with "Heat Reclaim Ventilator Type" and "Power Consumption During Stop" with "Adaptor Type".

The screenshot shows the 'Manual Setting' window with the following callouts:

- Calculation Type:** Normal, Heat Reclaim Ventilator or Adaptor Type
- Calculating Condition:** Defaulting settings are all "Yes".
- Model Name:** When existing model data is revised, the original model name up to 32 half width characters shall be input here.
- Buttons:** "Modify Coefficient" and "Consult Database".
- Selected data:** Selected data from the model data file can be input.
- Unchangeable data:** Coefficient Setup Unchangeable data are shown in grey.
- OK Button:** Press this button when the coefficient data needs to be revised. When the button is pressed, the model name is automatically changed to "Manual Input".

The window contains the following fields and controls:

- Air Conditioner No.: 1-1-00
- Model Name: FXYFP56MA
- Calculation Type: VRV Type
- Comment: [Empty text box]
- Calculating Condition:
 - Power Proportional Distribution: No Yes
 - include power during STOP: No Yes
 - include power of Heater: No Yes
 - include power of Fan: No Yes
- Coefficient Setup:
 - Cooling Coefficient a1: [Greyed out]
 - Cooling Coefficient a2: 0.04
 - Heating Coefficient b1: 1
 - Heating Coefficient b2: 0
 - Fan Rated Power Consumption: 1.74
 - Heater Rated Power Consumption: 1.82
 - Power Consumption During Stop: 0.051
 - Power Consumption During Stop: 0.02

8. Power Distribution Group Setting

1. Press "Setup Group" button to get the window shown below. Here, the group under calculation shall be shown in red and that under suspended calculation is shown in blue.
2. Press "New" button to set a new power distribution group. Select "Standard" for the type of the power distribution group (*1). The type of group cannot be changed after setting.
3. Pressing "Delete" button will delete the set power distribution group. (*2).
4. Press "Edit Group" button to register a port and an air conditioner to the power distribution group. (Refer to the next page for how to register.)
5. Press "Start Calculation" button to start calculation. Here, the group under calculation shall be shown in red and that under suspended calculation is shown in blue.
6. When "Stop Calculation" button is pressed, calculation finishes. Note that if calculation is finished, **the accumulated data of that day will be cleared when calculation starts next time.**
7. For the group under calculation, "Suspend Calculation" button is pressed, the calculation is suspended. When a button (display of the button varies depending on the group selected) is pressed again, calculation starts again. When calculation restarts, pulse meter values are realigned so that it can be used to for meter alignment.

(Note)

*1 Select "Standard" only for the group type. "Ice Storage" and "GHP" are for Japanese market only.

*2 The power distribution group under calculation or under suspended calculation cannot be deleted.

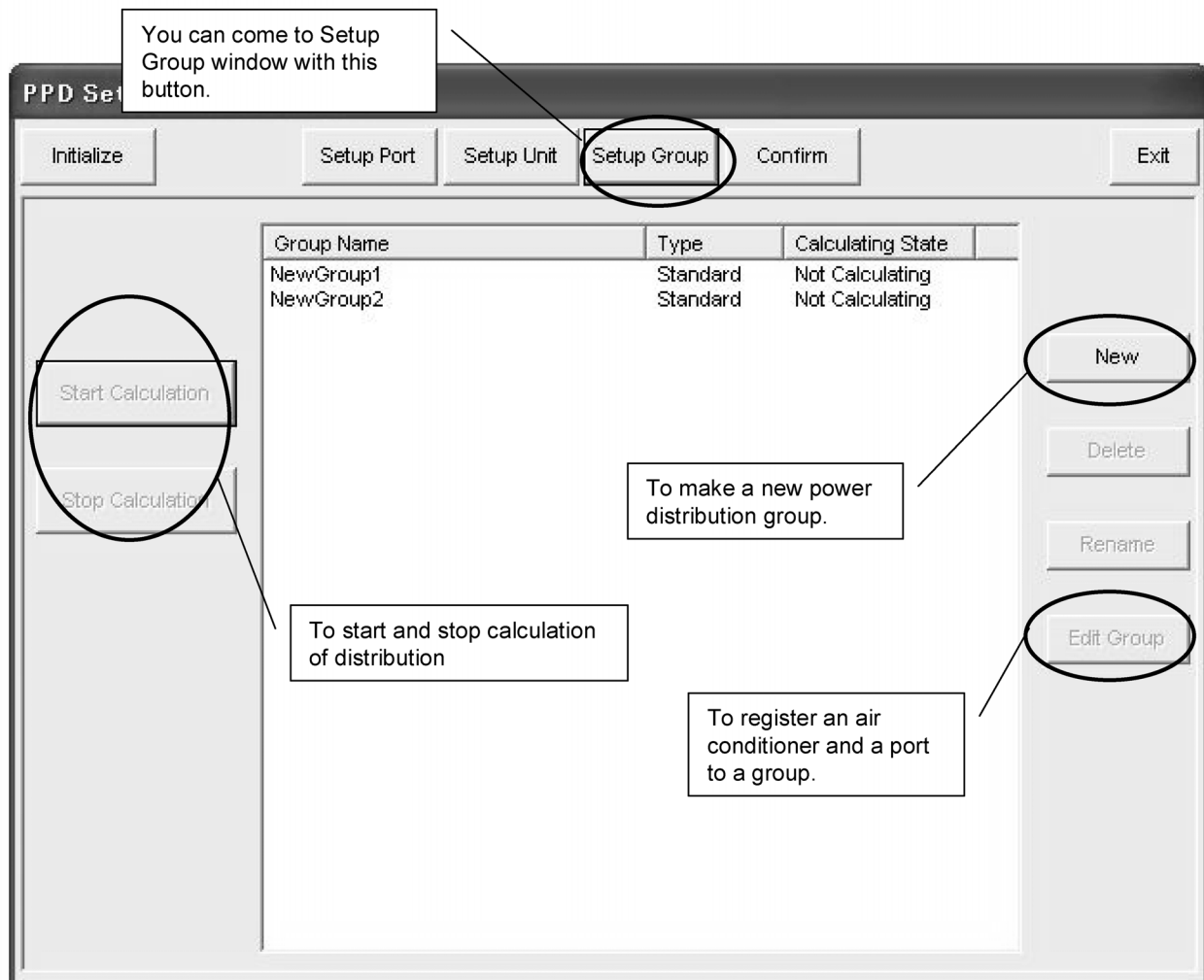

CB06A070B

8.1 Power Distribution Group Editing

1. Press "Edit Group" on the "Setup Group" window to open the window shown below (*1). Ports and air conditioner shown here are those exist in the same Interface for use in BACnet.
2. In both the Power Port (*2) box and the Air Conditioner box, the left rows show the control points registered in this power distribution group and the right rows show the control points not registered in any power distribution group.
3. Choose the control points to be registered from the right rows and add them to the left rows.
4. When "Special Setup" button is pressed, a window appears, which ask whether automatic proportional distribution shall be made for the constant power consumption type hardware. The automatic proportional distribution for the constant power consumption type hardware are a method of proportional distribution in which, when all the hardware in the group are of constant power consumption (Heat Reclaim Ventilator Type and Adaptor Type), the input pulses shall be distributed in proportion to the temporary power consumption but not the actual power consumption is equal to the temporary power consumption (operation time x rated power). Default setting is "Automatic Distribution".
5. When the editing is completed, press "OK" button to register the new settings.

(Note)

*1 Color of letters in the lists:

Ports: Black for the power ports

Air Conditioner: Black for the air conditioners in normal communication, light blue for those not in normal communication

*2 Port:

Wattmeter ports can be registered in any desired groups. (Setting of a mixture of different types of groups for the same port cannot be made.)

Editing (addition and deletion of ports and air conditioners) cannot be made for the groups under calculation or under suspended calculation.

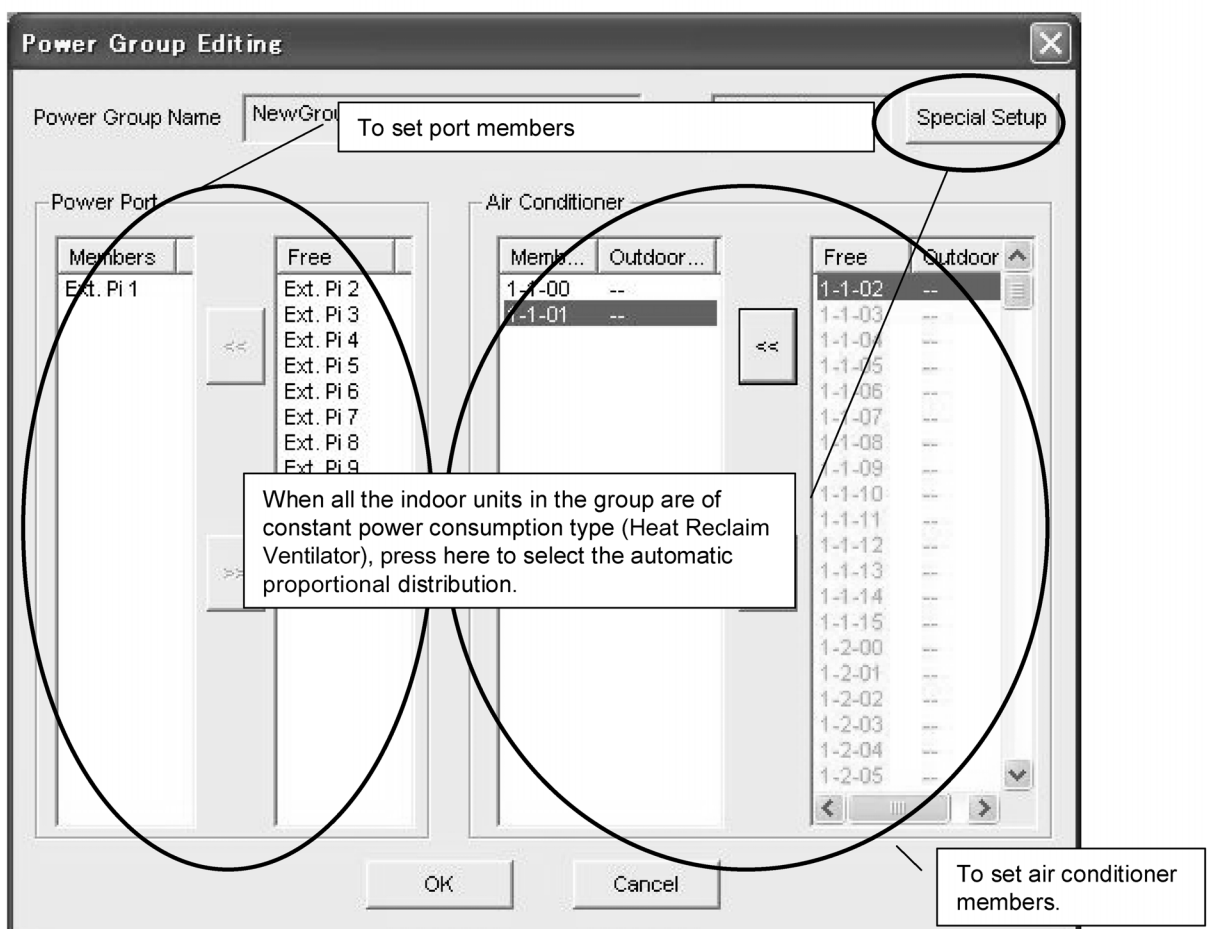

CB06A070B

9. Confirmation of Operation

Confirmation to see if the operation of the proportional distribution is made correctly shall be with following procedures.

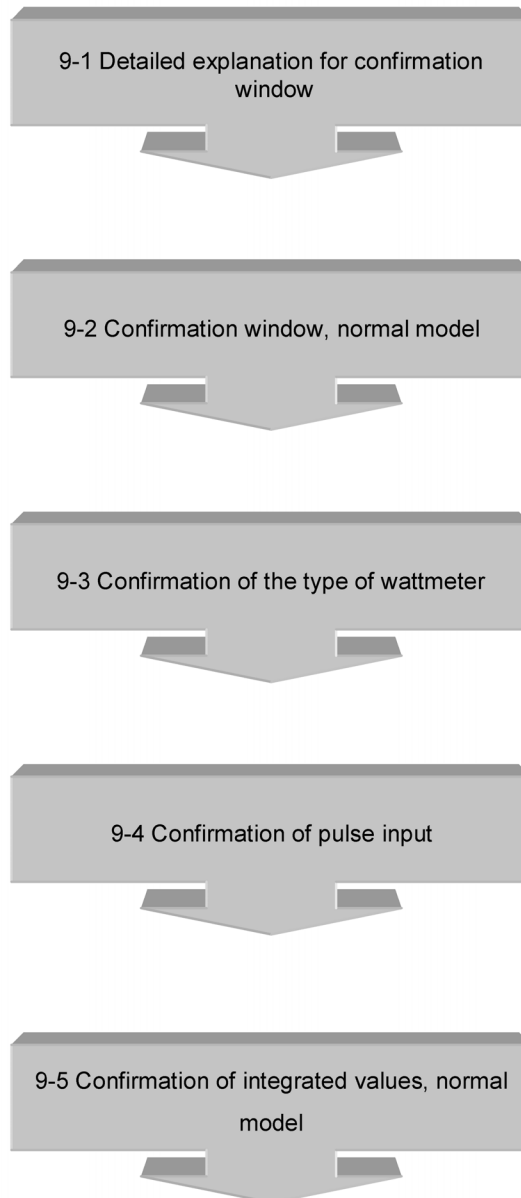

CB06A070B

9.1 Detailed Explanation for Confirmation Window

1. Press "Confirm" button to show the window shown below.
2. When a group is selected from the list, the buttons on the left will be displayed. By pressing each button, you can confirm present data of the indoor units, outdoor units and ports belonging to the group. Items to be confirmed with each button are as follows.

*[Calculate Power] : Data of past 48 hours

*[Present Calculated Value] : Accumulated data from 0:00 hour of the previous day to the last calculation hour

*[Temporary Power Consumption] : Calculation results of every one hour for the indoor units and the ports of the group

3. The present settings for all the PPD groups can be saved in the PC as a text file by pressing "Save Setup" button. The saved data can be taken at site to know the test run settings.

4. The saved data of settings are for confirmation only and cannot return the settings of all the PPD groups to the test run tool.

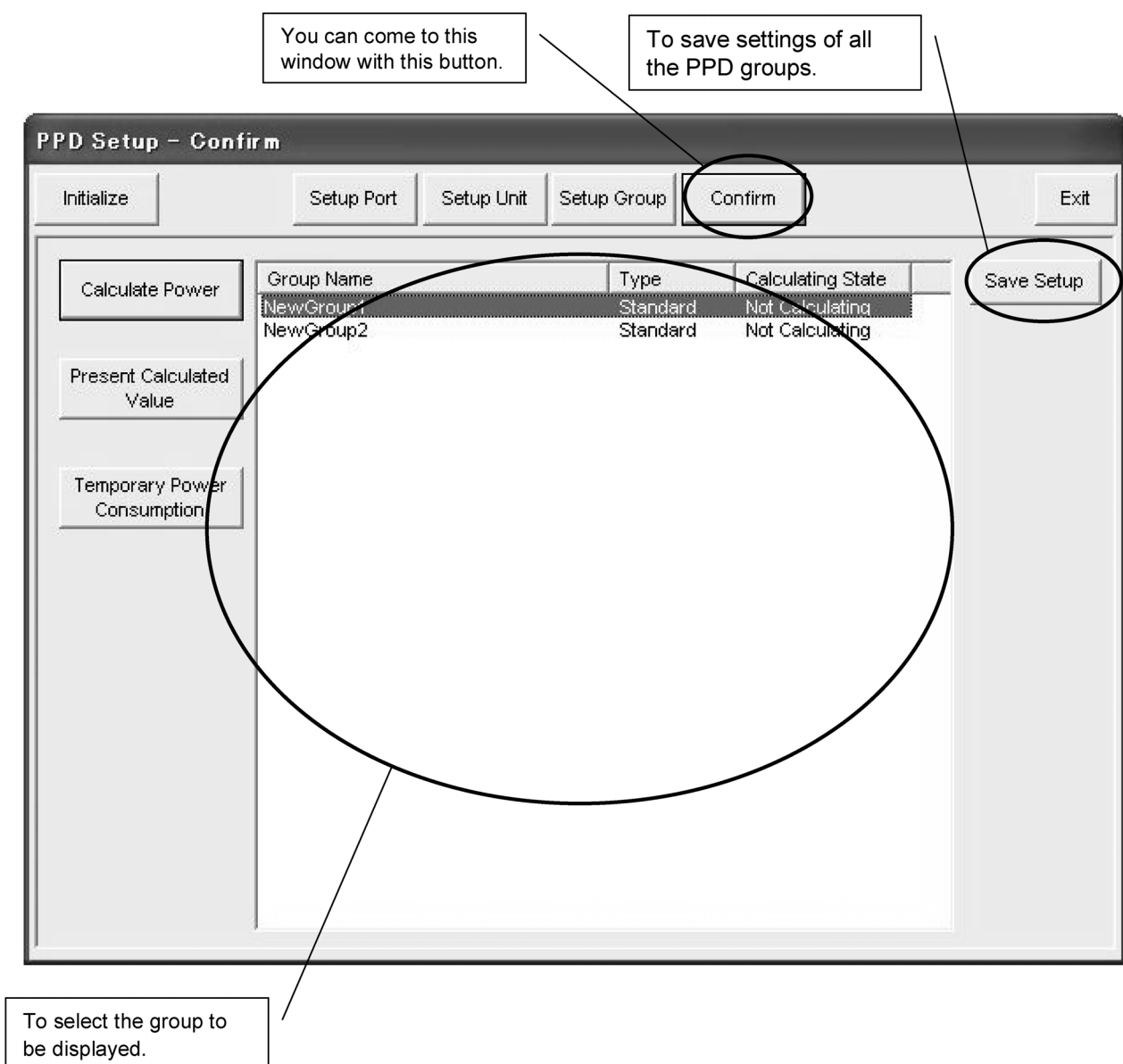

9.2 Confirmation Window, Normal Model

* Confirmation of integrated value

1. Press "Calculate Power" button on the "Confirm" dialog.
Select the time to be confirmed with "Search Time" button, and press "Retrieve" button to show the window shown below.

*1 In case of normal type distribution, data shown for "Indoor Unit" are as follows.

Amount (kWh) : The power amount for the period specified by "Search Time" will be displayed.

Integration : Integrated power amount from the start of calculation to the present will be displayed.

Idle power (kWh) : Only when the setting is that the power for suspended time is not distributed, integrated power amount for the period specified by "Search Time" will be displayed.

Integration : Only when the setting is that the power for suspended time is not distributed, integrated power amount for the suspended time from the start of calculation to the present will be displayed.

ThermoOn Time (min) : Thermo ON time for the period specified by "Search Time" will be displayed.

Op. Time (min) : Operation time of an indoor unit for the period specified by "Search Time" will be displayed.

Fan Op. Time (min) : Operation time of a fan in an indoor unit for the period specified by "Search Time" will be displayed.

Rate (%) : Distribution rate for the period specified by "Search Time" will be displayed.

*2 Rate (%) is calculated by averaging the total value of distribution rate of every one hour. Therefore, if there is one full suspended time, the total of distribution rate may not be 100%.

Calculated Power

Power Group Name: NewGroup1 Search Time: 2007/02/15 21:00 - 2007/02/15 21:00 Retrieve

No.	Amount...	Integration	Idle po...	Integration	Ther...	Op. ...	Fan ...	Rate
1-1-00	320.000	950.000	0.000	0.000	0	0	0	50
1-1-01	320.000	950.000	0.000	0.000	0	0	0	50
Total	640.000		0.000					100

Close

[Note]

1. Search time can be set at 1 hour period.
2. Maximum 49 hours' data can be displayed.

* Confirmation of the present integrated amount

1. Press "Present Calculated Value" button on the "Confirm" window to show the window shown below.
Here, you can see the calculated data from 0:00 hour of the previous day to the last calculation hour.
2. Invalid data due to abnormalities such as overflow and erroneous input pulses will be displayed with the marks of "#" before and after the value. And the color of letters for those data will be red.
3. Data display can be switched to for indoor units, ports and groups with pressing each tab.

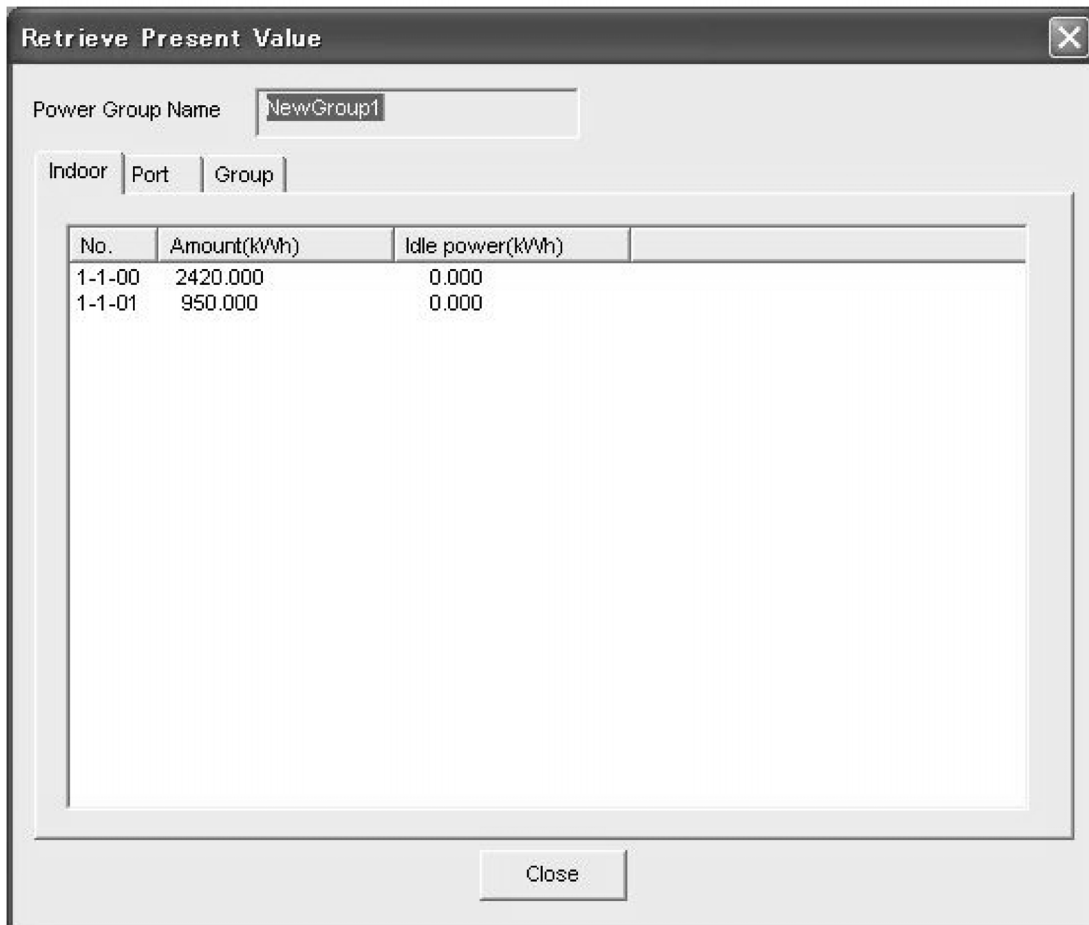

CB06A070B

* Confirmation of temporary power consumption

1. Press "Temporary Power Consumption" button on the "Confirmation" window to show the dialog shown below. Here, you can see the temporary power consumption from the last calculation time (0:00) to the present.
2. Data display can be switched to for indoor units and ports by pressing each tab. Data displayed for the normal model are those of indoor units and ports.

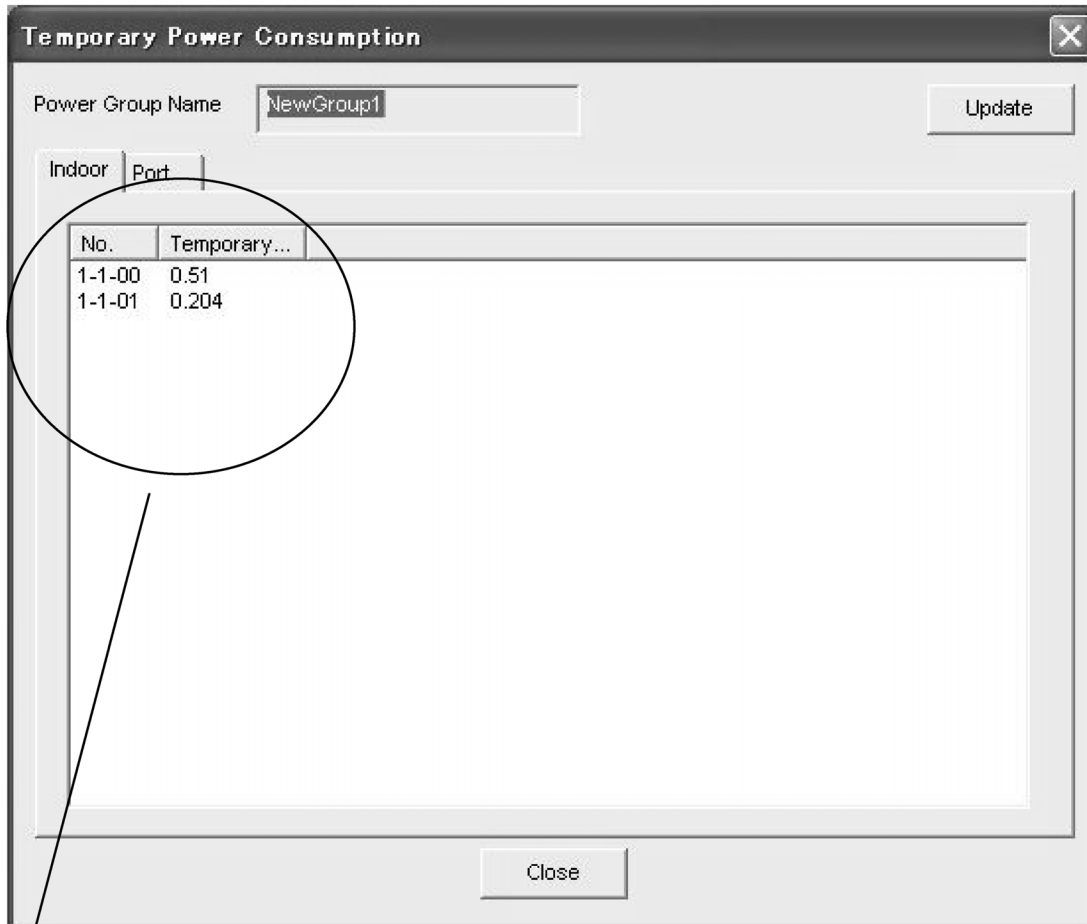

(Reference)

Calculation method for the charge calculation of the normal model is as follows:

Temporary power consumption of each indoor unit = power consumption of an indoor fan + power consumption of a heater + rated power consumption of cooling x a + rated power consumption of heating x b

$$a = (a1 + a2 \times T) \times \text{thermo step} / 10$$

$$b = (b1 - b2 \times T) \times \text{thermo step} / 10$$

a1,a2: cooling coefficient (*set by hardware registration)

b1,b2: heating coefficient (*set by hardware registration)

T: suction temperature

Actual power consumption of each indoor unit = total pulse input from a wattmeter x temporary power consumption of each air conditioner / total of temporary power consumption of all indoor units

CB06A070B

- 3. When the "Port" tab is selected on the Temporary Power Consumption window, following data will be shown.
Present pulse number: Total number of pulses input in one hour. The data is cleared every one hour.

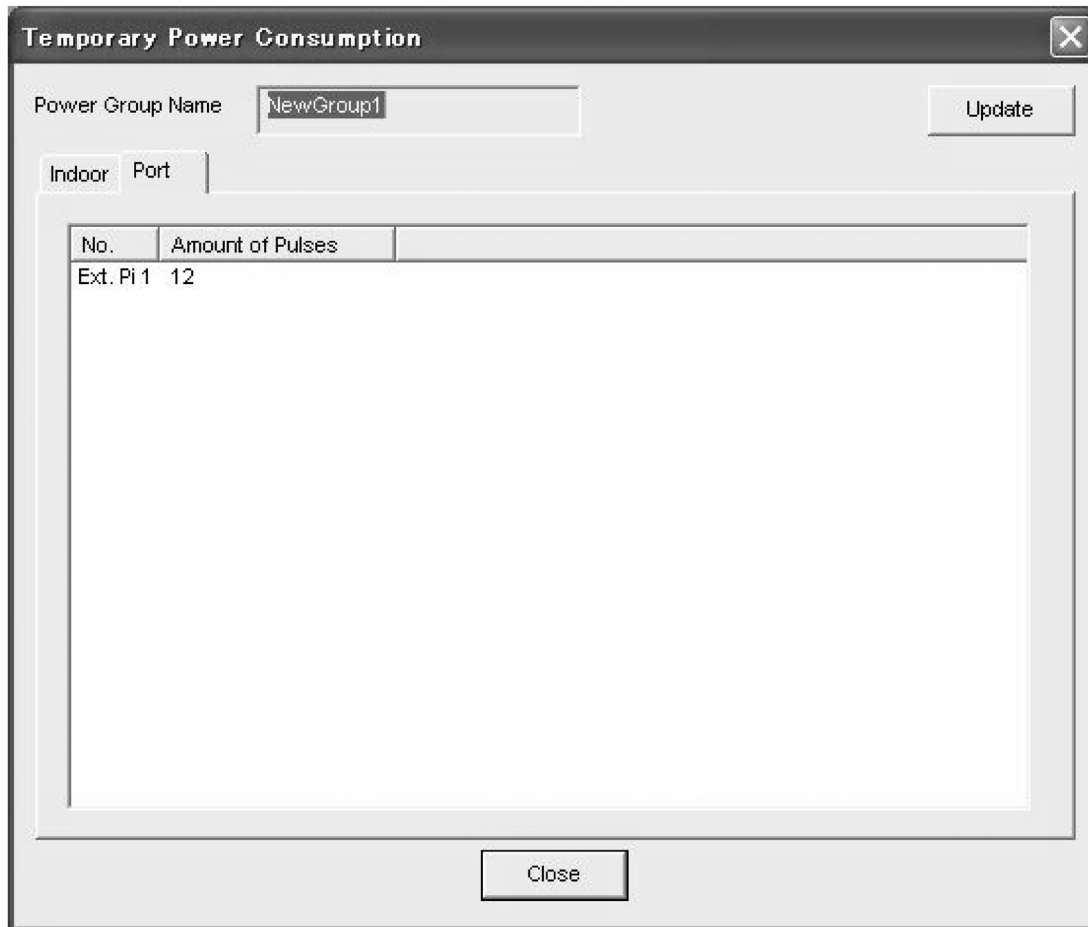

6

CB06A070B

9.3 Confirmation of the Type of Wattmeter

When power proportional distribution is made with the Interface for use in BACnet, at least one wattmeter is required. In practice, the total power value recognized by the Interface for use in BACnet is given by the pulse inputs from the wattmeter.

Thus, the wattmeter is very important for the Interface for use in BACnet, and it is necessary to confirm the specifications of the wattmeter to see if they meet the requirements of the Interface for use in BACnet.

[Check Points]

The wattmeter to be connected to the Interface for use in BACnet must satisfy all the following conditions.

- (1) The meter must be an integrated watt hour meter equipped with an pulse oscillator.
- (2) Output pulse unit must be either 1.0kWh/pulse or 10.0kWh/pulse.
- (3) Output pulse width must be in the range of 100 - 400msec.
- (4) The pulse oscillator must use a semiconductor relay.

Defects arisen from a wattmeter that does not meet the conditions.

- If the output pulse unit of the wattmeter is not same with the input pulse unit set in the setting of pulse input ports, following defects will arise. (Although the differences are not always 10 times or 1/10 times.)
- * In case that the output pulse units of the wattmeter is 1 kWh/pulse, while the setting of the pulse input port is 10 kWh/pulse: Results of power calculation will be approximately 10 times actual power consumption.
- * In case that the output pulse units of the wattmeter is 10 kWh/pulse, while the setting of the pulse input port is 1 kWh/pulse: Results of power calculation will be approximately 1/10 times actual power consumption.
- If the pulse oscillator is not a semiconductor relay type, the contact may have chattering, and one pulse may be recognized as multiple pulses.
(Pulses may not be read correctly with a reed switch type oscillator due to the contact chattering.)

(Note) As for the output pulse unit, confirm with a rating label of a wattmeter.

CB06A070B

9.4 Confirmation of Pulse Input

Confirmation shall be made to see if the pulse output from an integrated wattmeter is correctly received by the Interface for use in BACnet.

[Check points]

1. When an air conditioner is operated and an integrated wattmeter rotates, the pulse outputs from the wattmeter should be input in the Interface for use in BACnet.
 2. In case that multiple number of wattmeter are installed, the registered contents set in the proportional distribution group editing should correspond to the actual connections of wattmeter.
- * When an air conditioner in some group is operated and the wattmeter for it rotates, the pulse output from the wattmeter should be input in the port that has been registered for the proportional distribution group.

[Confirmation Method]

1. Record values (W1) of an integrated wattmeter. At the same time, record pulse numbers (P1) input in the Interface for use in BACnet from the wattmeter with "Amount of Pulses".
2. When the integrated wattmeter has changed to another one, record the values (W2) and record pulse numbers (P2) input in the Interface for use in BACnet from the wattmeter with "Amount of Pulses".
3. If $(W2 - W1) = (P2 - P1)$, it is OK.
4. Carry out above procedures for every connected wattmeter repeatedly.

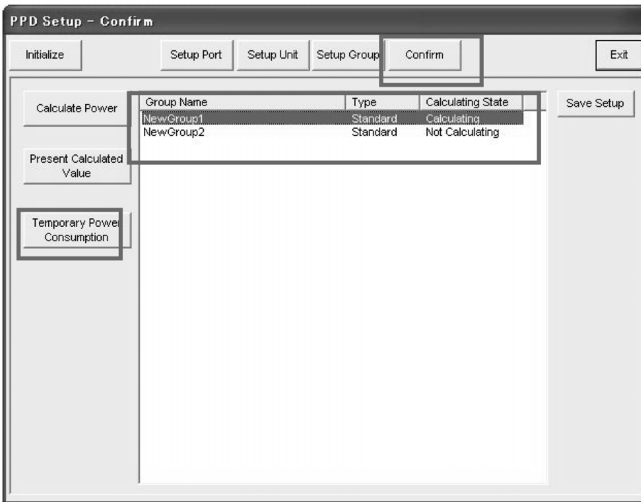

[Operation Method]

1. Press "Confirm" button to show the confirmation window
2. Select "Group Name" and press "Temporary Power Consumption" button.

6

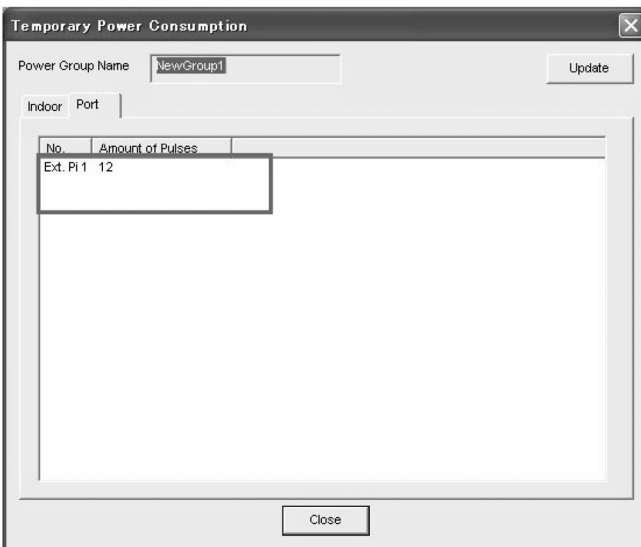

3. Select "Port" and confirm the "Amount of Pulses".

Present number of pulses: Total number of pulses input one hour before.
The number shall be cleared every one hour.

CB06A070B

9.5 Confirmation of Integrated Values, Normal Model

Confirmation shall be made to see if the integrated amount of power value distributed to each indoor unit meets the value of wattmeters.

[Check Point]

1. Confirmation shall be made for each distribution group.

[Confirmation Method]

- (1) Record value of a wattmeter on the hour. (W1)
- (2) On "Present Calculated value" window, read all the integrated value of all the indoor units registered in the same distribution group and record the total value of them. (A1)
- (3) Record value of a wattmeter on the next hour. (W2)
- (4) On "Present Calculated value" window, read all the integrated value of all the indoor units registered in the same distribution group and record the total value of them. (A2)
- (5) If $(W2 - W1) \approx (A2 - A1)$, it is OK.
- (6) Repeat above steps (1) to (5) for all the distribution groups.

W1,W2: Confirmation of value of wattmeter

A1,A2: Confirmation of value of test run tool

(Example) Carry out the following (1) to (5) in order.

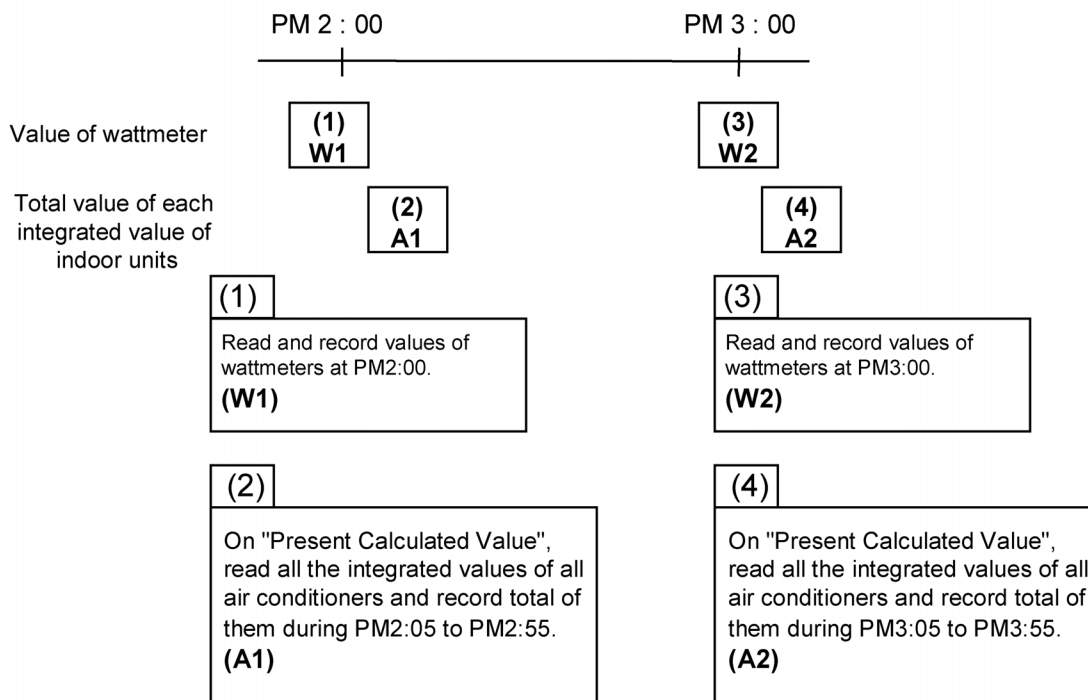

(5)
If $(W2 - W1) \approx (A2 - A1)$, it is OK.

(Note)
Power distributed value for each indoor unit is rounded up at the digit of 0.1 Wh (in order not to impose loss to an owner of a building). Therefore, total of the integrated value is calculated with little higher value than the actual value.

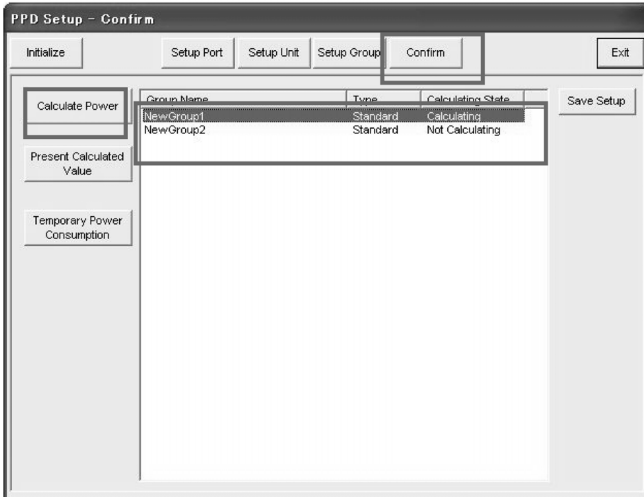

[Operation Method]

1. Press "Confirm" button to show the confirmation window.
2. Select a group name.
3. Press "Calculate Power" button.

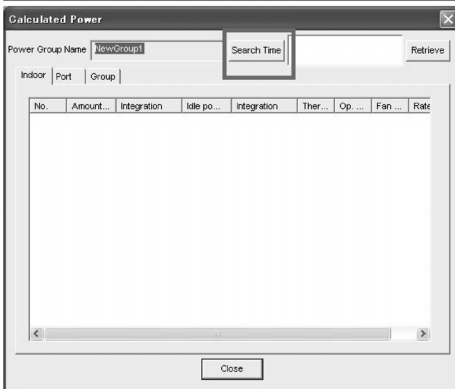

4. Press "Search Time" button.

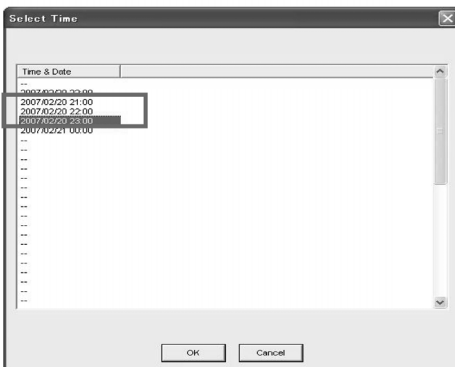

5. Select the time to be confirmed.

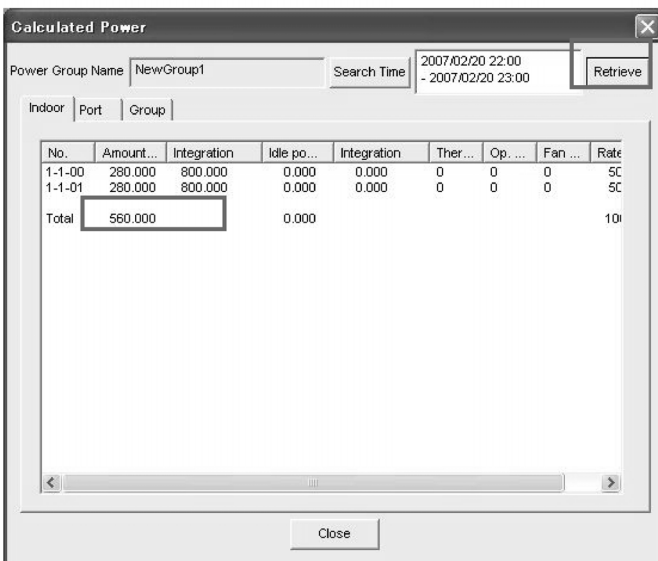

6. Press "Retrieve" button to show the window shown in the left.
Total of all the integrated value of all indoor units in the same distribution group is a value between A2 and A1.

* Difference of one hour out of the specified period is displayed.

10. Error Messages

Errors in the power proportional distribution calculation are as follows:

Error messages will be displayed on the malfunction history in the test run tool (SetupBACnet).

Following contents of malfunction, additional information, occurrence time (year/month/day hour:minute: second) and occurrence/recovery will be displayed on the malfunction history.

Malfunction History (Main Unit)

When the following errors occurred, the ALARM LED of the unit will flicker and the error contact of the unit (Do-1) will be closed. It can be masked by using the test run tool (SetupBACnet). (Refer to CB06A069)

<i>Contents of Malfunction</i>	<i>Additional Information (Warning Timing)</i>	<i>Malfunction Conditions</i>	<i>Measures to the Malfunction</i>
Operation overflow of the day	Additional Information Malfunction Classification Port d *d : port number (1-4) Warning Timing Once when malfunction occurs	Actual power consumption value of an indoor unit calculated at the hour exceeds 500,000 kWh.	Power consumption value shall remain to be 500,000 kWh. Mark the data with an invalid bitt so that the actual power consumption value or the historical data is identified to be invalid when being read. The invalid bitt is reset everyday so that warning can be given again.
		Suspended power value of an indoor unit calculated at the hour exceeds 500,000 kWh.	Power consumption value shall remain to be 500,000 kWh. Mark the data with an invalid bitt so that the actual power consumption value or the historical data is identified to be invalid when being read. The invalid bitt is reset everyday so that warning can be given again.
Temporary power consumption 1000kWh or more and pulse 0	Additional Information Malfunction Classification Port d *d : port number (1-4) Warning Timing At every malfunction	In spite of the total sum of the temporary power consumption of an indoor unit in a distribution group is more than 1000 kWh, the input pulse is 0.	Calculation of power shall be continued. Mark the data with an invalid bitt so that the actual power consumption value or the historical data is identified to be invalid when being read. The invalid bitt is reset everyday.
Backup start	Additional Information None Warning Timing When the Interface for use in BACnet is started	Startup is made with backup data due to power failure during data saving.	Calculation shall be continued.
BCC error	Additional Information None Warning Timing When the Interface for use in BACnet is started	Information stored in SRAM is destroyed.	Clear the destroyed information and start calculation.

CB06A070B

Part 7 Installation Manual

1. Installation Manual	184
1.1 DMS502B51	184
1.2 DAM411B51 (Option DIII Board)	190
1.3 DAM412B51 (Option Di Board)	193

1. Installation Manual

1.1 DMS502B51

1 Components

The following parts are attached to this unit.
Make sure to check them before installation.

Interface for use in BACnet	1 set
INSTALLATION MANUAL	1 copy

2 Names and functions of each part

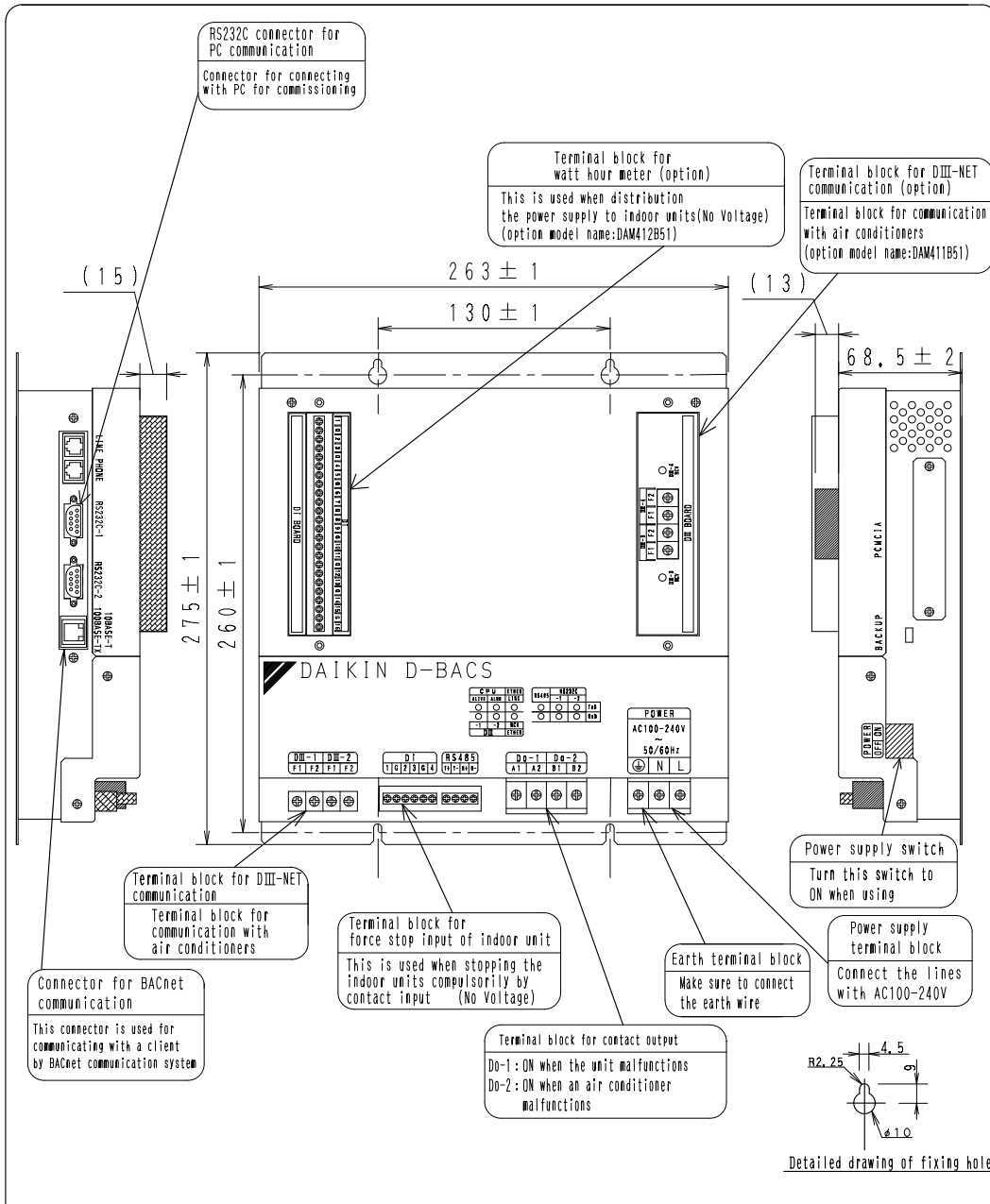

1P191169D

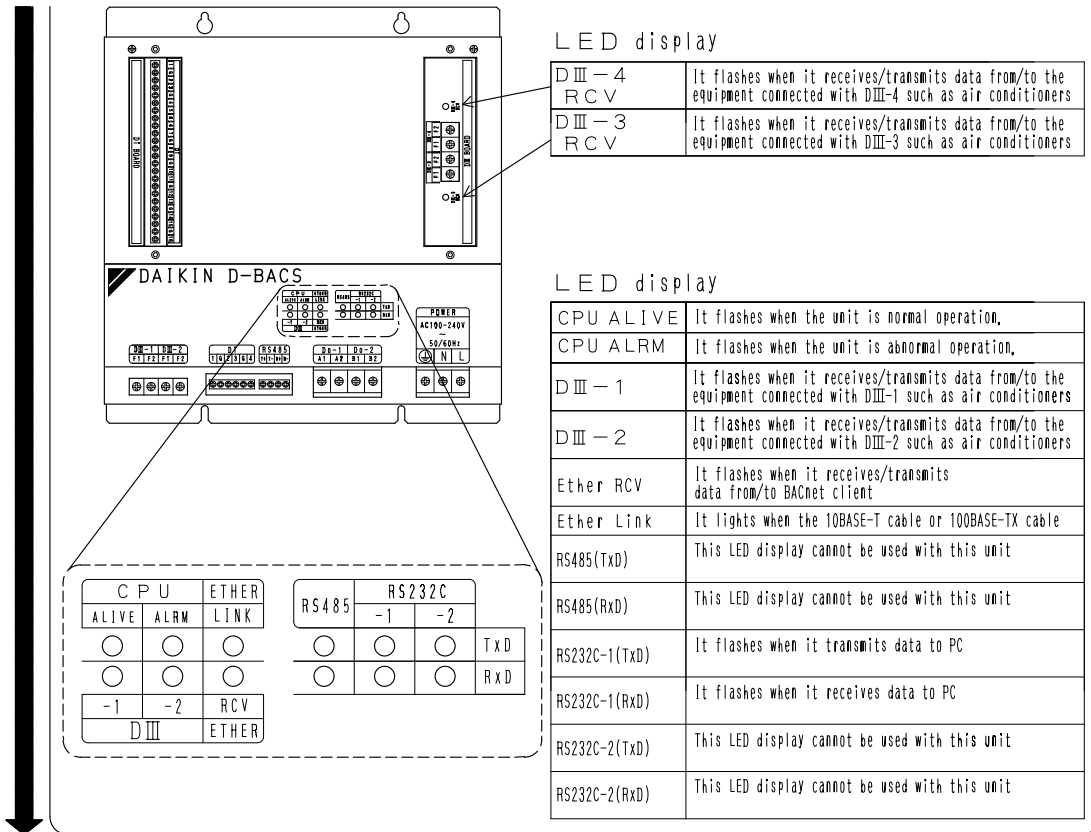

3 Installation

Do not fail to turn OFF the indoor unit power switch before installing Interface for use in BACnet. Failure to observe this instruction could result in electric shock.

● Location

Make sure to install the unit on the inside of the inaccessible and lockable (or needed to use exclusive tools to open) electrical component box installed indoors where the effect of electromagnetic wave or dust can be avoided. The minimum depth required for installation is 100mm

● Required installation space

Keep the minimum amount of space indicated in the below drawing from walls, and between units when installed in series.

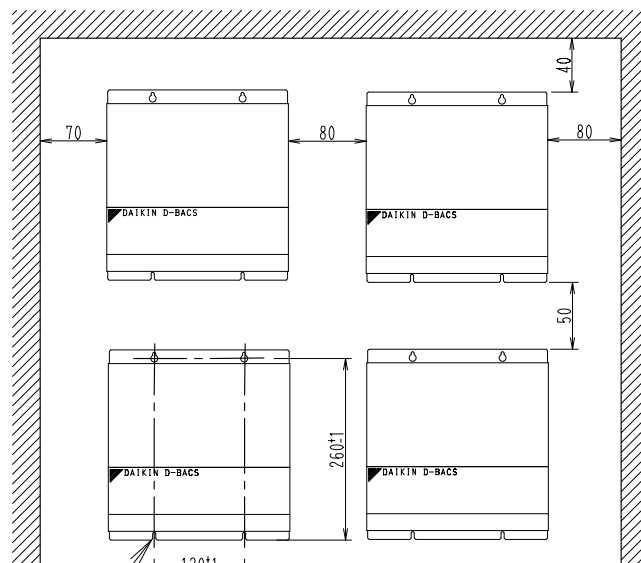

Fix the intelligent Processing Unit firmly with the installation screws(M4)

1P191169D

TO BACK

● How to install

For installation direction follow the drawing shown below.

UP

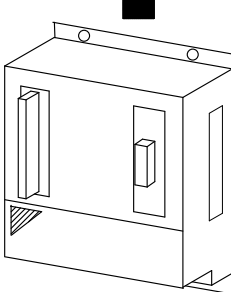

< CAUTION >

Make sure to install the unit vertically. Do not install the unit horizontally, because it may cause malfunction.

Setting "BACK-UP BATTERY VALIDATE" switch
 (shifted to OFF when being shipped from the shop, -- Back-up battery set to INVALIDATE)
 For the switch to back up the clock, etc. in case of any power failure, actuate it from OFF side (knob is located above) to ON side (knob is located below) as shown in the sketch below.

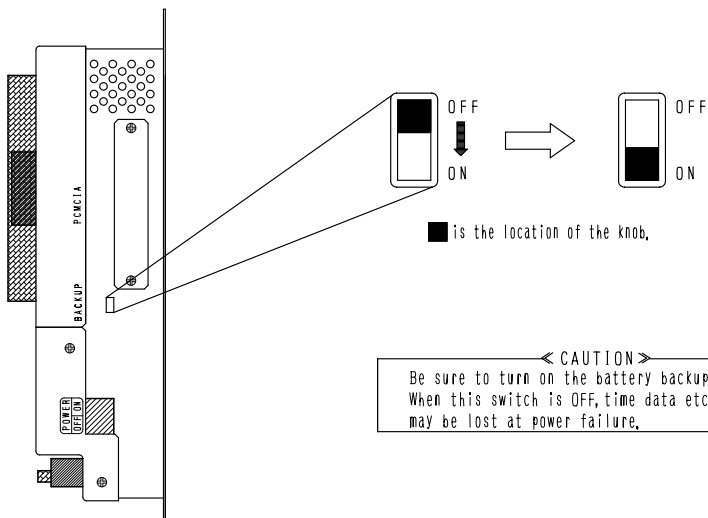

■ is the location of the knob.

< CAUTION >

Be sure to turn on the battery backup switch. When this switch is OFF, time data etc. may be lost at power failure.

1P191169D

4 「DIII-NET master」 setting

- Make sure to connect the unit with 「DIII-NET master」 (Do not remove the master central setting connector.) Remove the master central setting connectors of the centralized management controllers or ON/OFF controllers when using together with other centralized controllers such as centralized management controllers or ON/OFF controllers.

5 Malfunction of unit

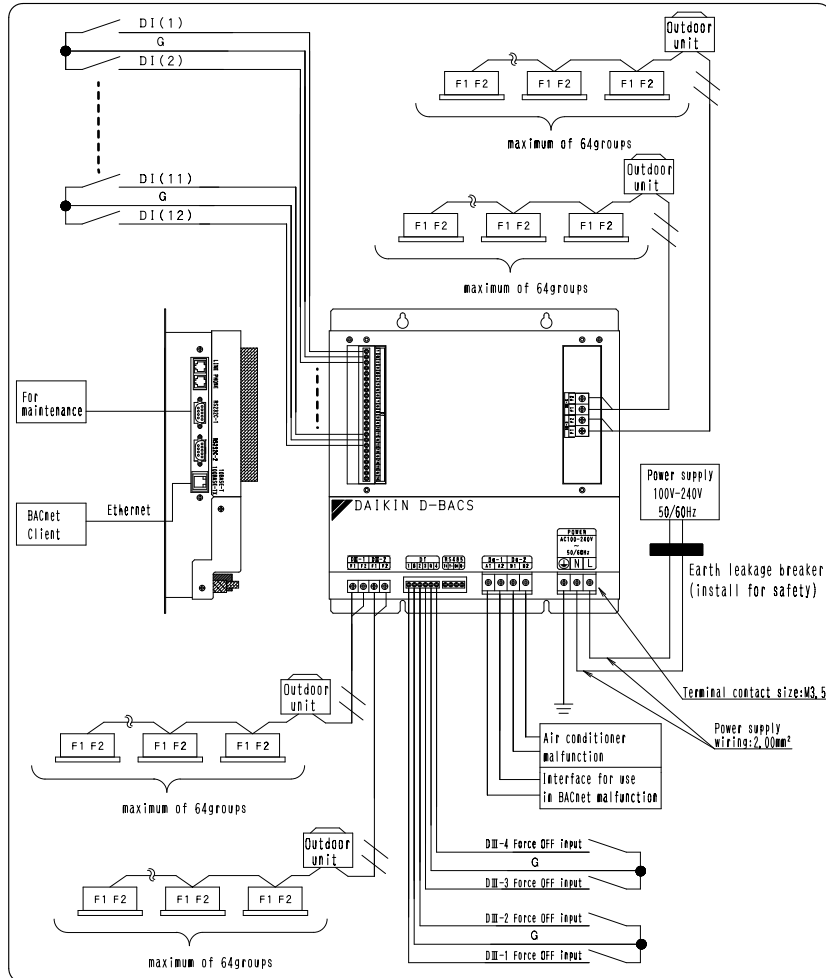

6 Electric Wiring Connection

Do not fail to turn OFF the indoor unit power switch before installing Interface for use in BACnet. Failure to observe this instruction could result in electric shock.

■ Everything relating with field wiring must be supplied in the field.

● DIII-NET wiring

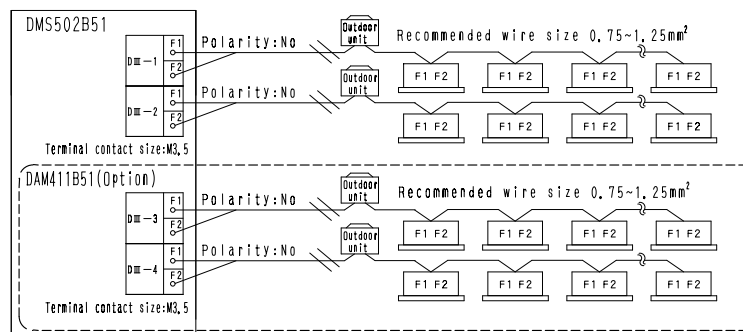

Cautions for wiring

1. Do not use multicore cables with 3 or more cores
2. Use wires of sizes between 0.75mm² and 1.25mm²
3. Do not bind the wire for DIII-NET
4. Wirings for DIII-NET must be isolated from the power lines
5. Wire length: Max 1000m

1P191170D

● No voltage contact input wiring

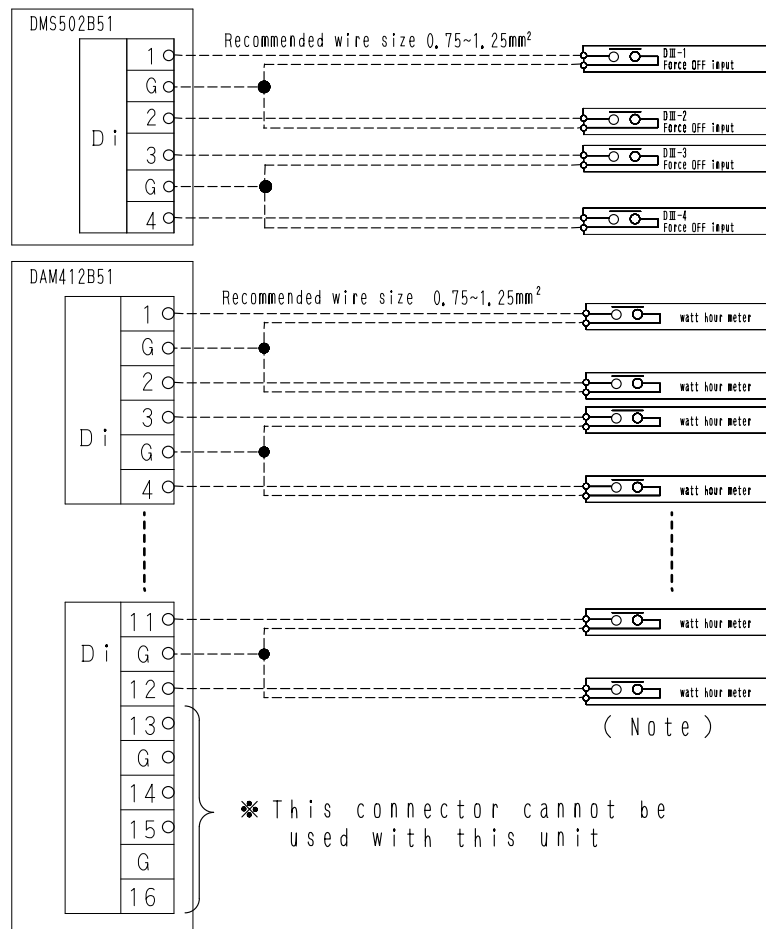

(Note) : Use a meter that outputs one pulse of a width from 40~400ms, per one kWh.

The pulse of watt hour meter

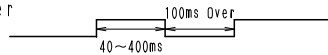

Cautions for wiring

1. The input are all the no voltage contact
2. Use a contact which can guarantee minimum application load DC16V and 10mA
3. Do not use multicore cables with three or more cores
4. Use wires of sizes between 0.75mm² and 1.25mm²
5. Do not bind the wire for control
6. Wirings for control must be isolated from the power lines
7. Terminals G are inter-connected. Connecting to either one is allowed, but the number of cables connectable to one terminal is limited to 2 pieces
8. Wire length:Max 150m

● No voltage contact output wiring

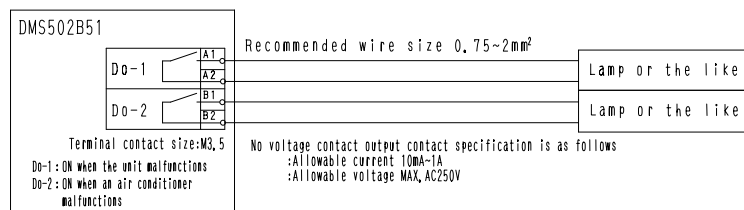

Cautions for wiring

1. Do not use multicore cables with three or more cores
2. Use wires of sizes between 0.75mm² and 2mm²
3. Do not bind the wire for control
4. Wirings for control must be isolated from the power lines
5. Wire length:Max 150m

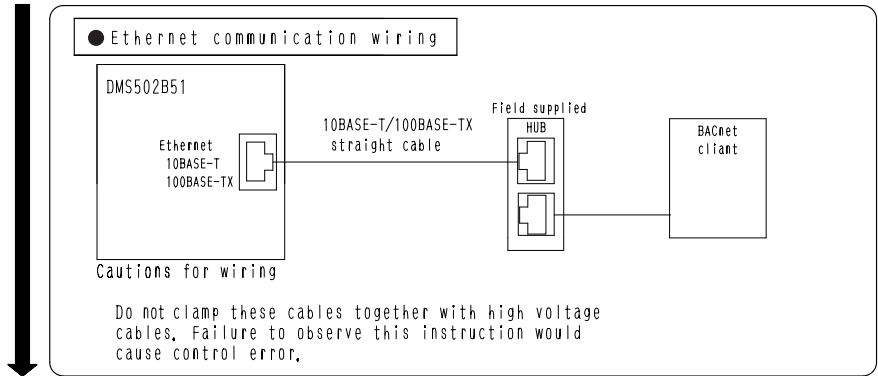

7 Setting group No. for centralized control

Set the group number of each group of the indoor unit from the remote controller. (In case of no remote controller, also connect the remote controller and set the group No. Then, remove the remote controller.)

- Turn ON the power of the indoor unit and interface for use in BACnet. (Unless the power is ON, no setting can be made.)
Check that the installation and electrical wiring are correct before turning the power supply ON. (When the power supply is turned ON, all LCD appear once and the unit may not accept the operation for about one minute with the display of "FF".)
- While in the normal mode, hold down the " " button for a minimum of 4 seconds. The remote controller will enter the FIELD SET MODE.
- Select the MODE No. " " with the " " button.
- Use the " " button to select the group No. for each group.
(Group numbers increase in the order of 1-00, 1-01, . . . 1-15, 2-00, . . . 4-15)
- Press " " to set the selected group No.
- Press " " to return to the NORMAL MODE.

NOTE

- For details on making settings from the simplified remote controller, refer to the instruction manual of the unit.
- See the instruction manuals which came with the Ventiair and adapters (i. e., multi-purpose adapters) for details on their Group No. settings.

NOTICE Be sure to keep the operation manual for maintenance.

1P191170D

1.2 DAM411B51 (Option DIII Board)

1 Components

The following parts are attached to this unit.
Make sure to check them before installation

mini-wrench



Option DIII board
DAM411B51

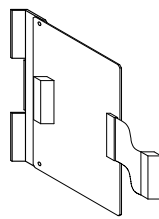

panel cover
for option



INSTALLATION
MANUAL



2 Outline of functions

Do not fail to turn OFF the indoor unit power switch before Interface for use in BACnet.
Failure to observe this instruction could result in electric shock.

This unit is for adding 2 port to the DIII-NET communication port by installing it on the Interface for use in BACnet DMS502B51.

- Make sure to connect the unit with 「DIII-NET master」
(Do not remove the master central setting connector.)
Remove the master central setting connectors of the centralized management controllers or ON/OFF controllers when using together with other centralized controllers such as centralized management controllers or ON/OFF controllers.

Outside dimension of PCB

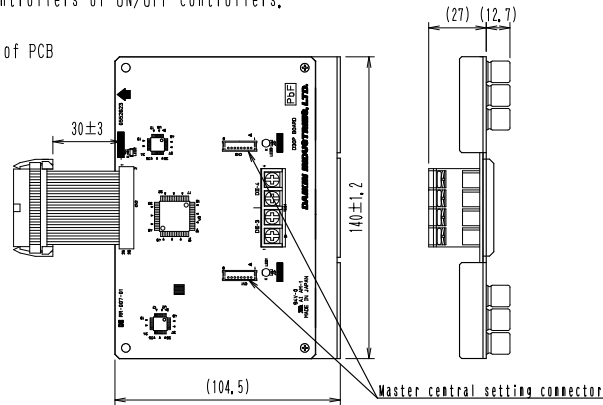

1P191165C

③ Installation

Do not fail to turn OFF the indoor unit power switch before Interface for use in BACnet. Failure to observe this instruction could result in electric shock.

Before installing the PCB, check that the power supply is turned OFF. Since PCB's are weak to static electricity, make sure to remove the static electricity accumulated in the worker's body. (The accumulated static electricity can be removed by touching the earthed controlboard and the like.)

- ① Remove the front cover of Interface for use in BACnet and remove the blind cover attached to the front cover with the attached mini-wrench.

Caution: Keep the removed screws. These screws for fixing the front cover and the blind cover(2 for each) will be required for reassembling.

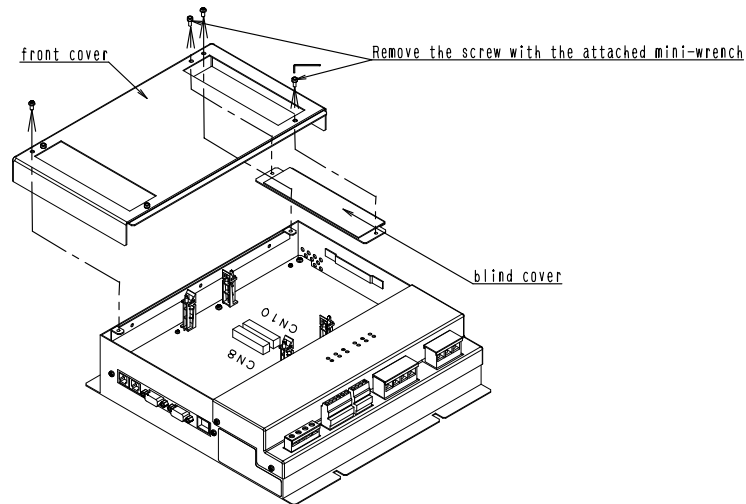

- ② As shown in the figure below, insert the connector DIIIboard into the connector CN10 of Interface for use in BACnet until it clicks, then hook the latch of DIIIboard to the hook hanger, and put the hole of DIIIboard into the spacer and fix it.

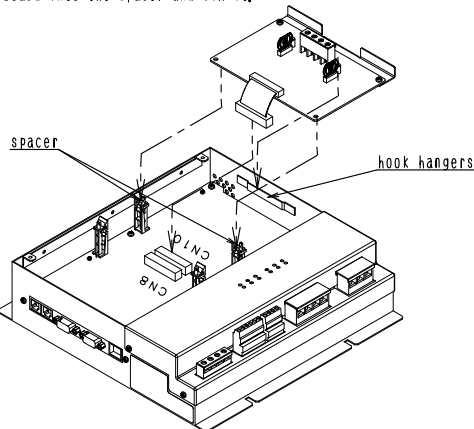

- ③ Fix the panel cover for option to the front cover with the attached mini-wrench. After that, fix the front cover to Interface for use in BACnet.

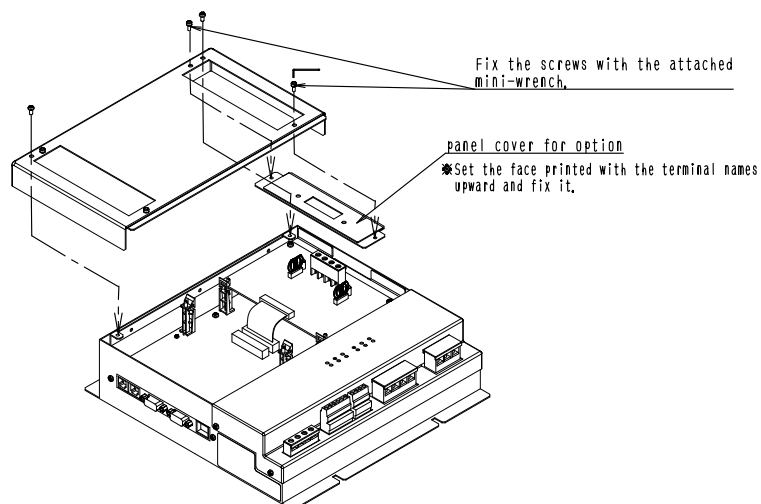

1P191165C

4 For external wiring (Do not fail to use a round crimp terminal with reinforcing sleeve for safety wiring connection to the Interface for use in BACnet,)

■ Everything relating with field wiring must be supplied in the field.

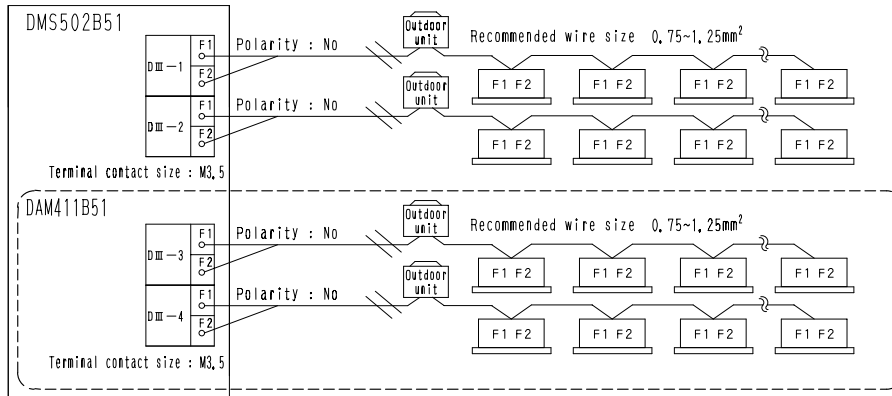

LED display
This unit has the following LED display. When each corresponding port transmits or receives the data the LED flashes.

- Cautions for wiring
1. Do not use multicore cables with 3 or more cores
 2. Use wires of sizes between 0.75mm² and 1.25mm²
 3. Wire length:Max 1000m
 4. Do not bind the wires for DIII-NET
 5. Wirings for DIII-NET must be isolated from the power lines,
 6. Terminal contact size :M3,5

5 Setting group No. for centralized control

Set the group number of each group of the indoor unit from the remote controller, (In case of no remote controller, also connect the remote controller and set the group No. Then, remove the remote controller.)
(1) Turn ON the power of the indoor unit and Interface for use in BACnet,
(Unless the power is ON, no setting can be made.)
Check that the installation and electrical wiring are correct before turning the power supply ON,
(When the power supply is turned ON, all LCD appear once and the unit may not accept the operation for about one minute with the display of "BB".)

- (2) While in the normal mode, hold down the " " button for a minimum of 4 seconds,
The remote controller will enter the FIELD SET MODE.
- (3) Select the MODE No, " " with the " " button,
- (4) Use the " " button to select the group No, for each group,
(Group numbers increase in the order of 1-00, 1-01, . . . 1-15, 2-00, . . . 4-15)
- (5) Press " " to set the selected group No.
- (6) Press " " to return to the NORMAL MODE.

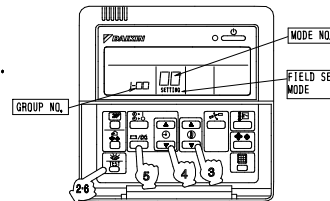

NOTE) • For details on making settings from the simplified remote controller, refer to the instruction manual of the unit.
• See the instruction manuals which came with the VentiAir and adapters (i.e., multi-purpose adapters) for details on their Group No. settings.

NOTICE Be sure to keep the operation manual for maintenance.

1P191165C

1.3 DAM412B51 (Option Di Board)

1 Components

The following parts are attached to this unit.
Make sure to check them before installation

Mini-wrench



Option Di board
DAM412B51

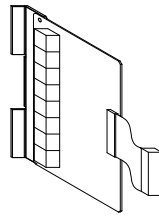

panel cover
for option

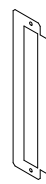

INSTALLATION
MANUAL

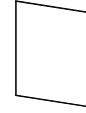

2 Outline of functions

Do not fail to turn OFF the indoor unit power switch before Interface for use in BACnet.
Failure to observe this instruction could result in electric shock.

This unit is for 12 points of Di input (no voltage contact input) by installing it on the Interface for use in BACnet DMS502B51.

Outside dimension of PCB

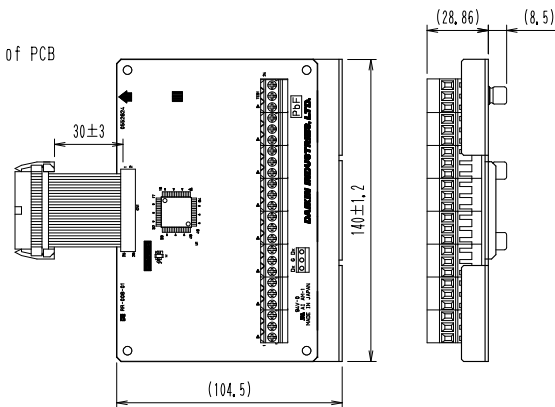

1P191166D

3 Installation

Do not fail to turn OFF the indoor unit power switch before Interface for use in BACnet. Failure to observe this instruction could result in electric shock.

Before installing the PCB, check that the power supply is turned OFF. Since PCB's are weak to static electricity, make sure to remove the static electricity accumulated in the worker's body. (The accumulated static electricity can be removed by touching the earthed controlboard and the like.)

- ① Remove the front cover of Interface for use in BACnet(DMS502B51) and remove the blind cover attached to the front cover with the attached mini-wrench.

Caution: Keep the removed screws. These screws for fixing the front cover and the blind cover(2 for each) will be required for reassembling.

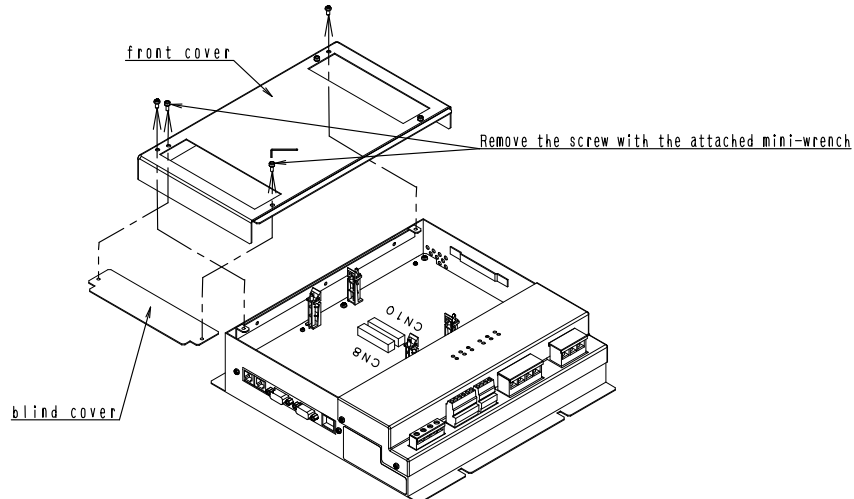

- ② As shown in the figure below, insert the connector Di board into the connector CN8 of Interface for use in BACnet until it clicks, then hook the latch of Di board to the hook hanger, and put the hole of Di board into the spacer and fix it.

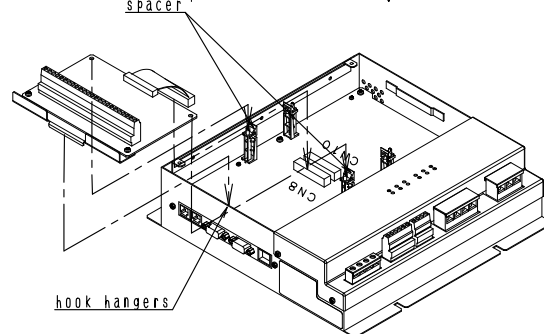

- ③ Fix the panel cover for option to the front cover with the attached mini-wrench. After that, fix the front cover to Interface for use in BACnet.

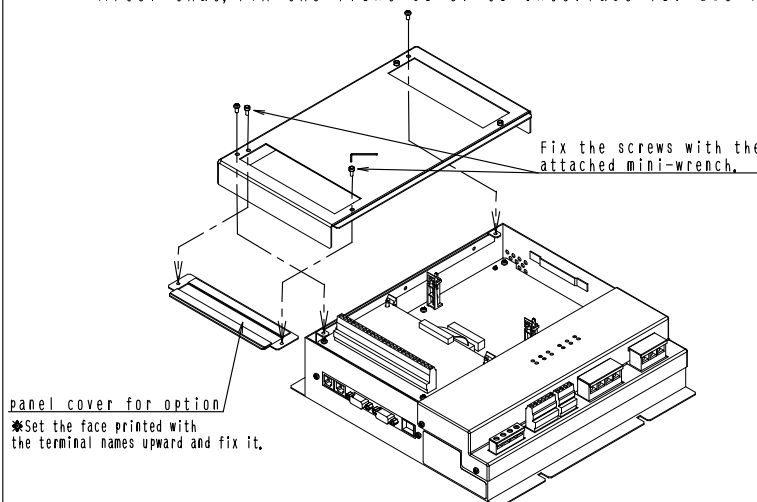

4 For external wiring

■ Everything relating with field wiring must be supplied in the field.

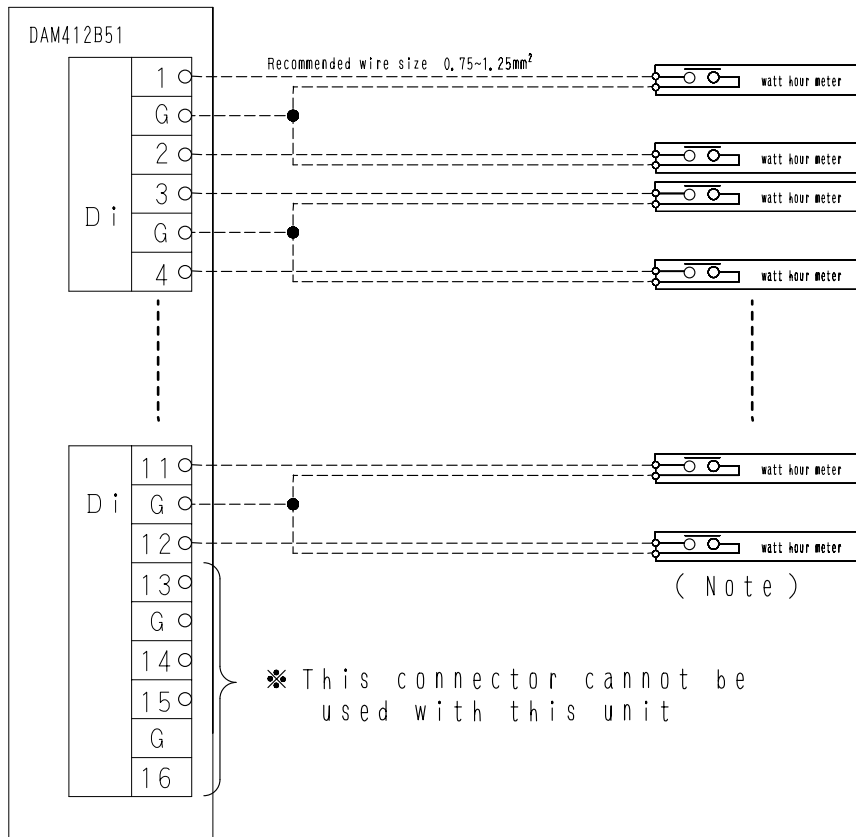

(Note) : Use a meter that outputs one pulse of a width from 40~400ms, per one kWh.

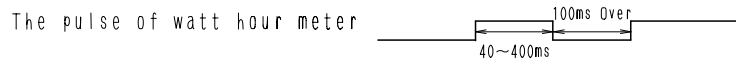

Cautions for wiring

1. The input are all the no voltage contact
2. Use a contact which can guarantee minimum application load DC16V and 10mA
3. Do not use multicore cables with 3 or more cores
4. Use wires of sizes between 0.75mm² and 1.25mm²
5. Do not bind the wire for control
6. Wirings for control must be isolated from the power lines
7. Terminals G are inter-connected. Connecting to either one is allowed, but the number of cables connectable to one terminal is limited to 2 pieces
8. Wire length:Max 150m

C: 1P191166D

Part 8

Troubleshooting

1. Troubleshooting Interface for use in BACnet [®] with LED indication.....	198
1.1 Troubleshooting with CPU ALIVE LED, CPU ALRM (ALARM) LEDs	198
1.2 Troubleshooting with ETHER LINK LED, ETHER RCV LEDs	200
1.3 Troubleshooting with DIII-1-4 LEDs	201
1.4 Troubleshooting with RS232C-1 TxD, RxD LEDs	202
1.5 Troubleshooting with RS232C-2 TxD, RxD LEDs	203

1. Troubleshooting Interface for use in BACnet® with LED indication

1.1 Troubleshooting with CPU ALIVE LED, CPU ALRM (ALARM) LEDs

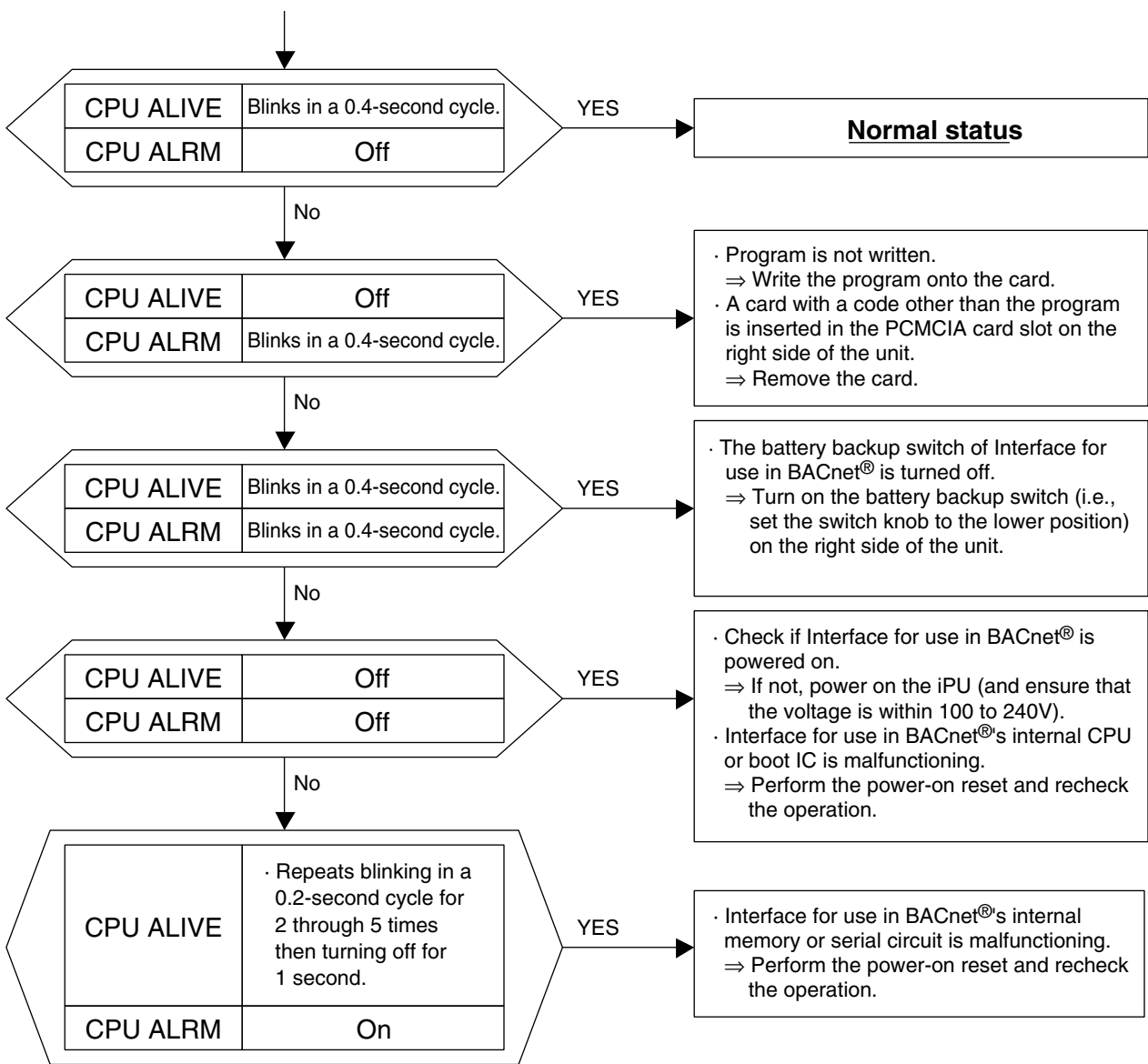
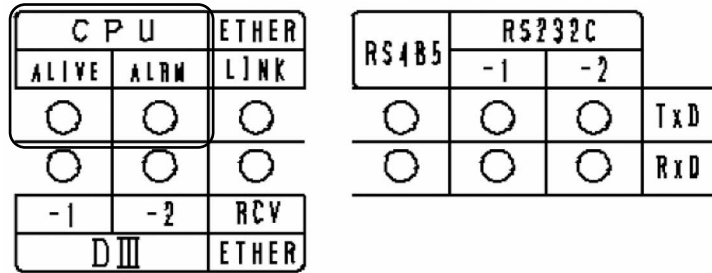

Continued onto next page

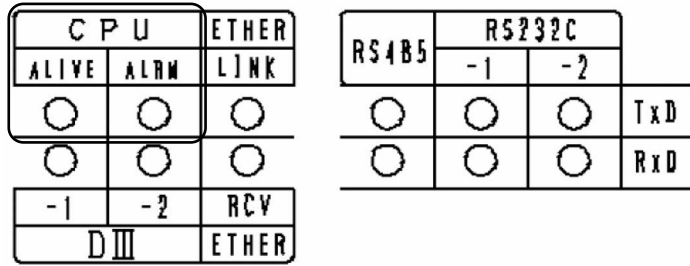

Continued onto next page

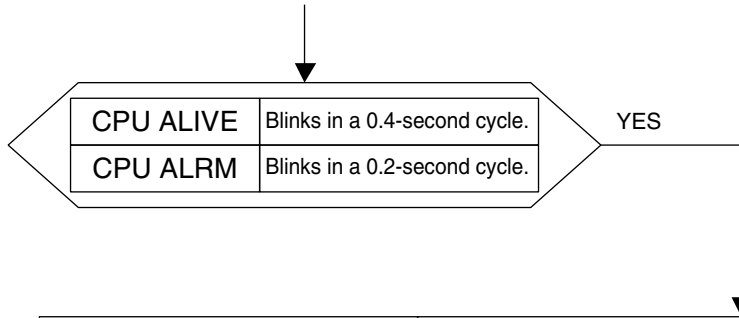

Item		Error condition	Note
DIII-NET	No response from any air-conditioner	Communication error of all the indoor units on the DIII-NET has been detected.	Automatically recovers when the communication error disappears.
	Multiple Interfaces for use in BACnet® exist, or iPU or DMS-IF exists on the same DIII-NET.	· Multiple Interfaces for use in BACnet® are installed. · A central device which cannot co-exist with Interfaces for use in BACnet® exists (with the same communication address) : DMS-IF iPU	
	Overlapping parent central devices	Multiple devices are specified as "parent" on the DIII-NET. ⇒ Only Interface for use in BACnet® should be specified as "parent".	
	DIII-NET polarity detection circuit error	A polarity detection error has occurred on the DIII-NET. ⇒ For instance, the DIII-NET line was connected with the unit powered on.	
	A central device which cannot co-exist with Interface for use in BACnet® exists on the DIII-NET.	A unification adaptor for computerized control or parallel interface has been detected on the DIII-NET.	
Power proportional distribution	Provisional power consumption is 1000 kWh or more and pulse 0	Power proportional distribution calculator has detected the provisional power consumption 1000 kWh or more and pulse 0.	Occurs when the pulse input is disconnected.
	Calculation overflow for current day	Power proportional distribution calculator has detected a calculation overflow for the current day.	
	Backup start	Power proportional distribution calculator has executed a backup start.	Occurs when BBRAM and Flash memory contents are destroyed.
	BCC error	Power proportional distribution calculator has detected a BCC error.	

1.2 Troubleshooting with ETHER LINK LED, ETHER RCV LEDs

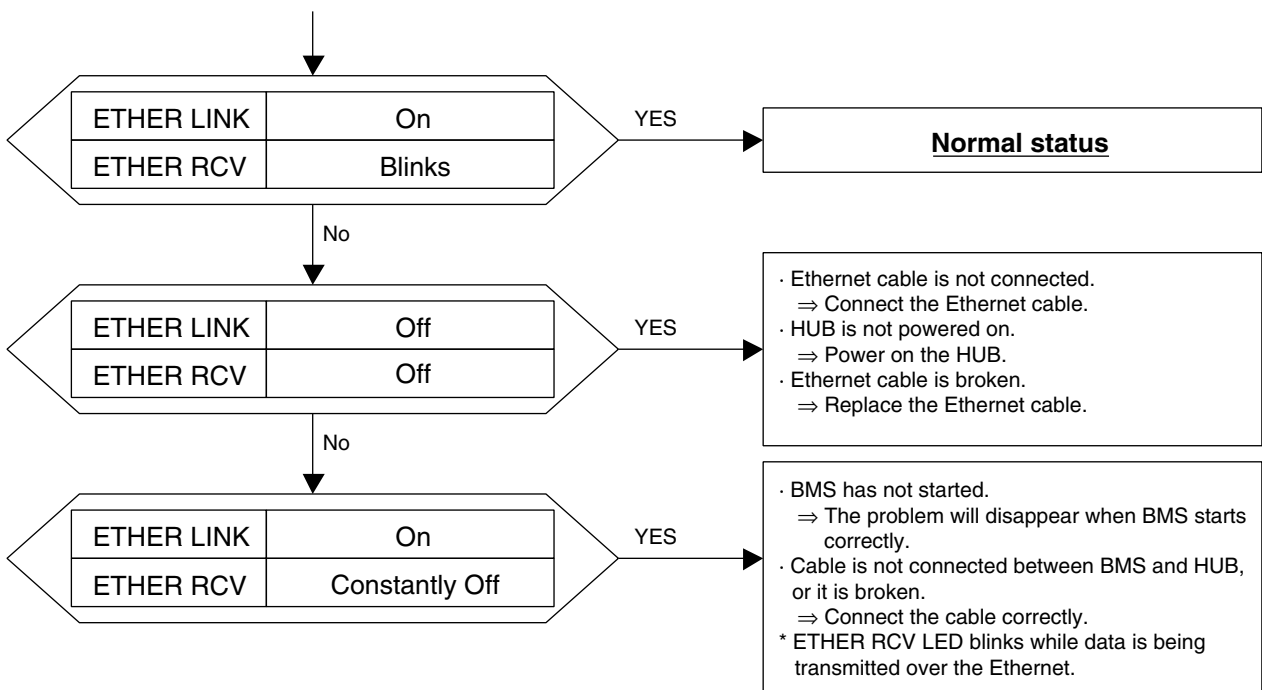
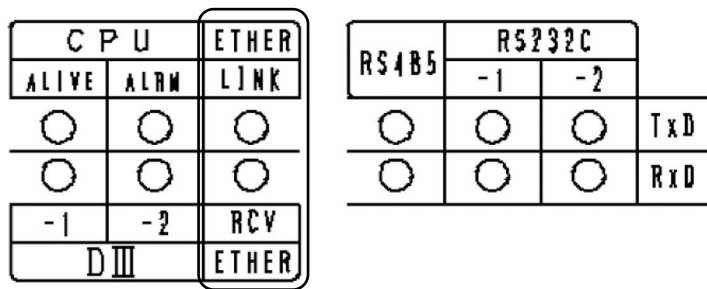

1.3 Troubleshooting with DIII-1-4 LEDs

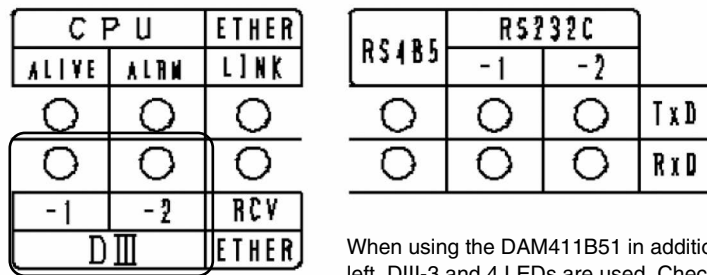

When using the DAM411B51 in addition to the configuration shown to the left, DIII-3 and 4 LEDs are used. Check only the ports to which the air conditioners are connected.

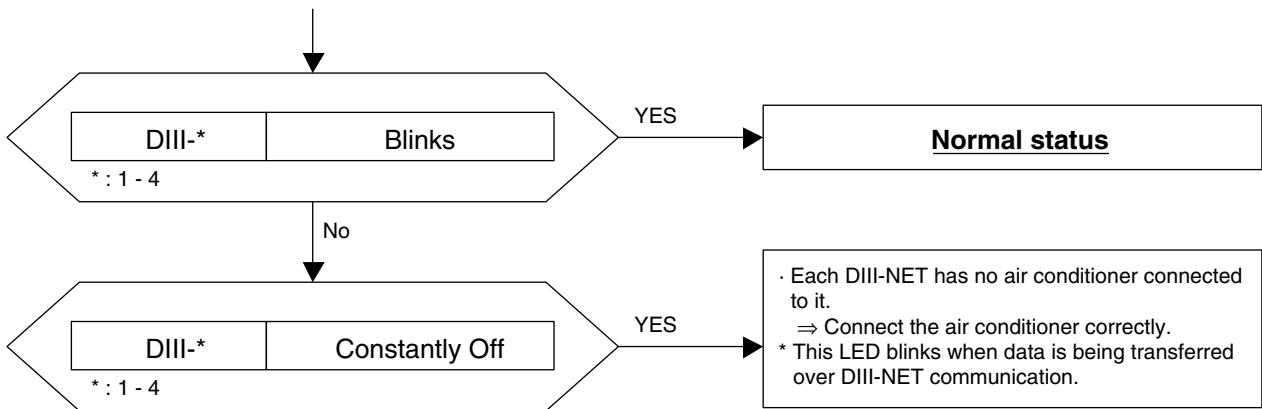

1.4 Troubleshooting with RS232C-1 TxD, RxD LEDs

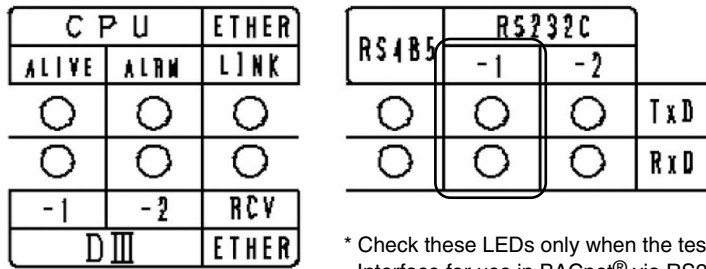

* Check these LEDs only when the test operation PC is connected to Interface for use in BACnet® via RS232C.
 RS232C-1 TxD blinks when Interface for use in BACnet® is transmitting data.
 RS232C-1 RxD blinks when Interface for use in BACnet® is receiving data from the test operation PC.

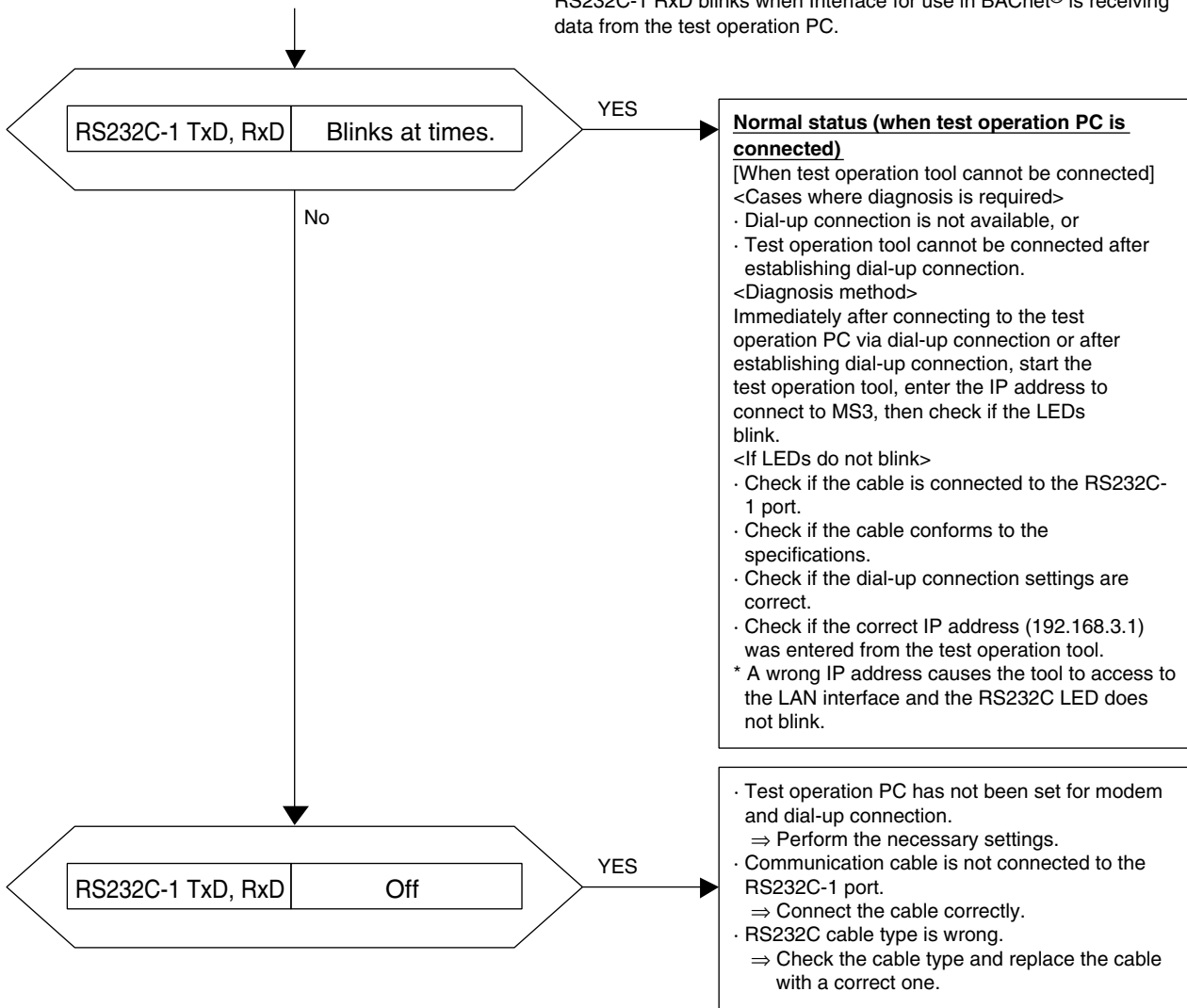

1.5 Troubleshooting with RS232C-2 TxD, RxD LEDs

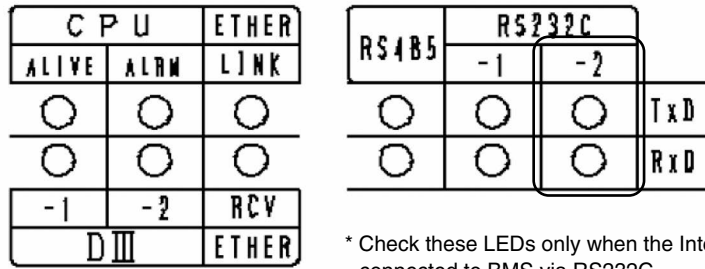

* Check these LEDs only when the Interface for use in BACnet® is connected to BMS via RS232C.
 RS232C-2 TxD blinks when Interface for use in BACnet® is transmitting data.
 RS232C-2 RxD blinks when Interface for use in BACnet® Interface is receiving data from BMS.

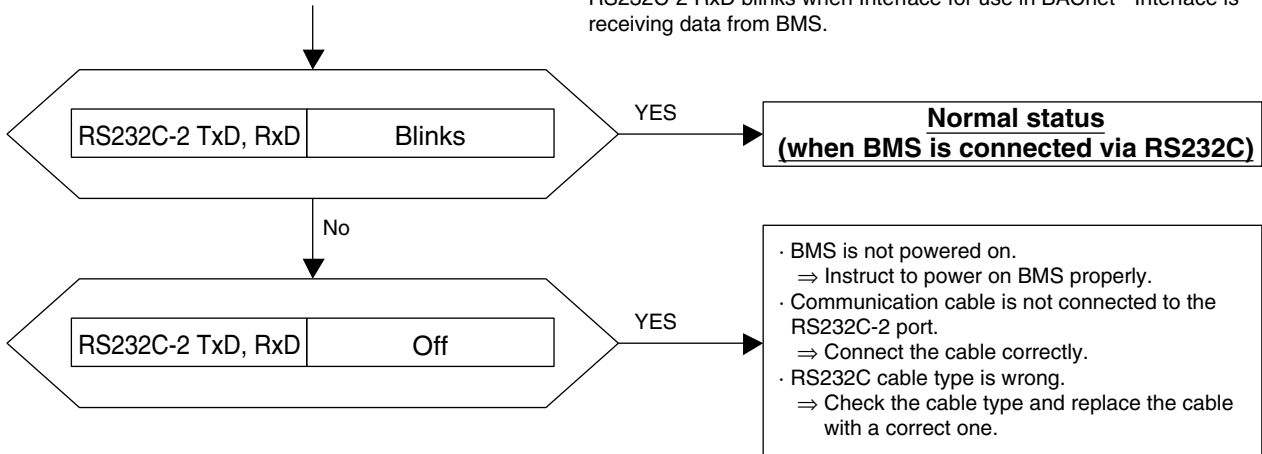

* RS485 is not used and LED off is the normal status.

Part 9

Interface for use in BACnet®

Project Job Flow

- 1. Interface for use in BACnet® Project Job Flow206
 - 1.1 Engineering Flow of Interface for use in BACnet® until Installation.....206
 - 1.2 Initial Settings Required Items for Interface for use in BACnet®208

1. Interface for use in BACnet® Project Job Flow

1.1 Engineering Flow of Interface for use in BACnet® until Installation

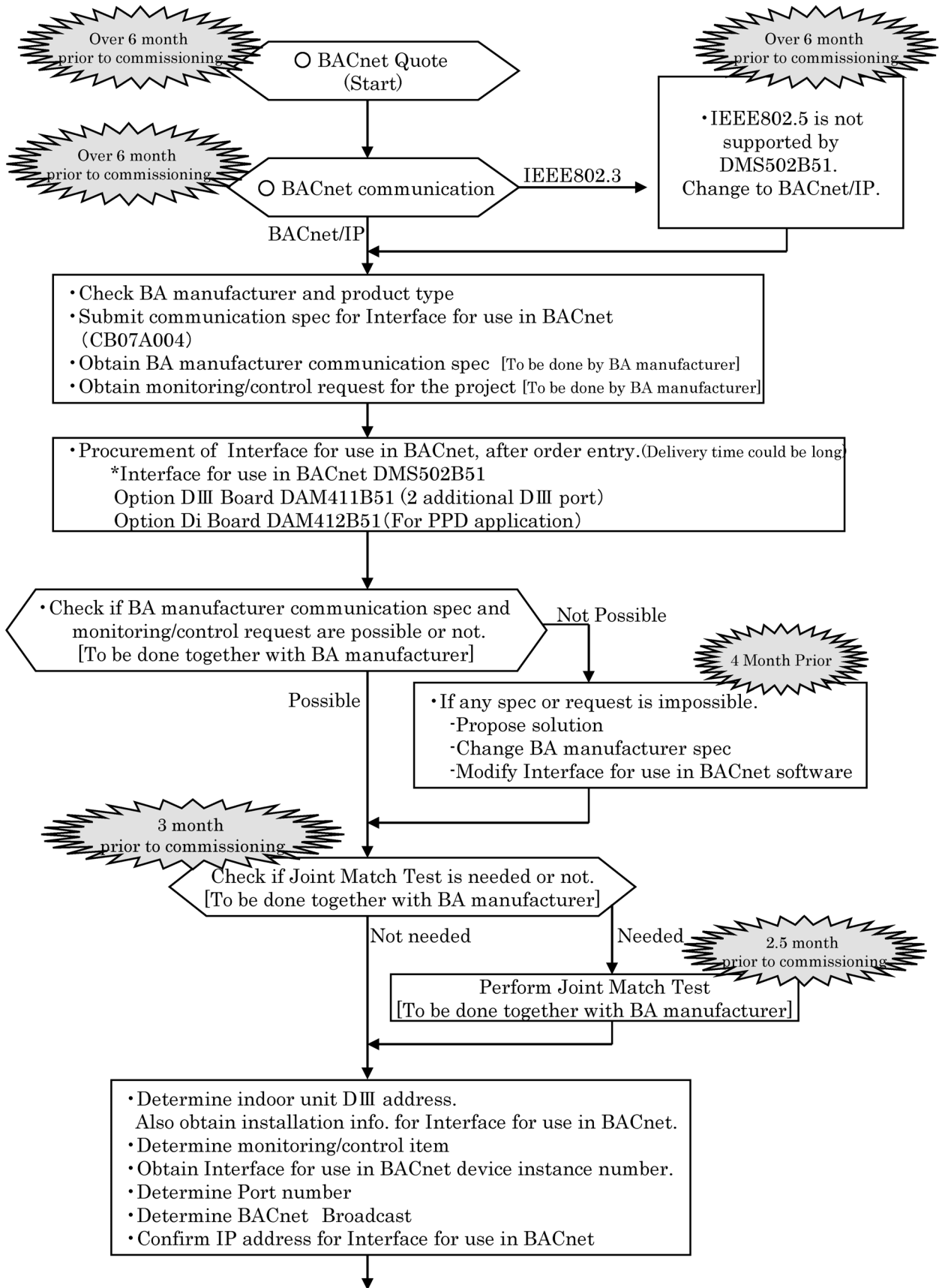

To Next Page

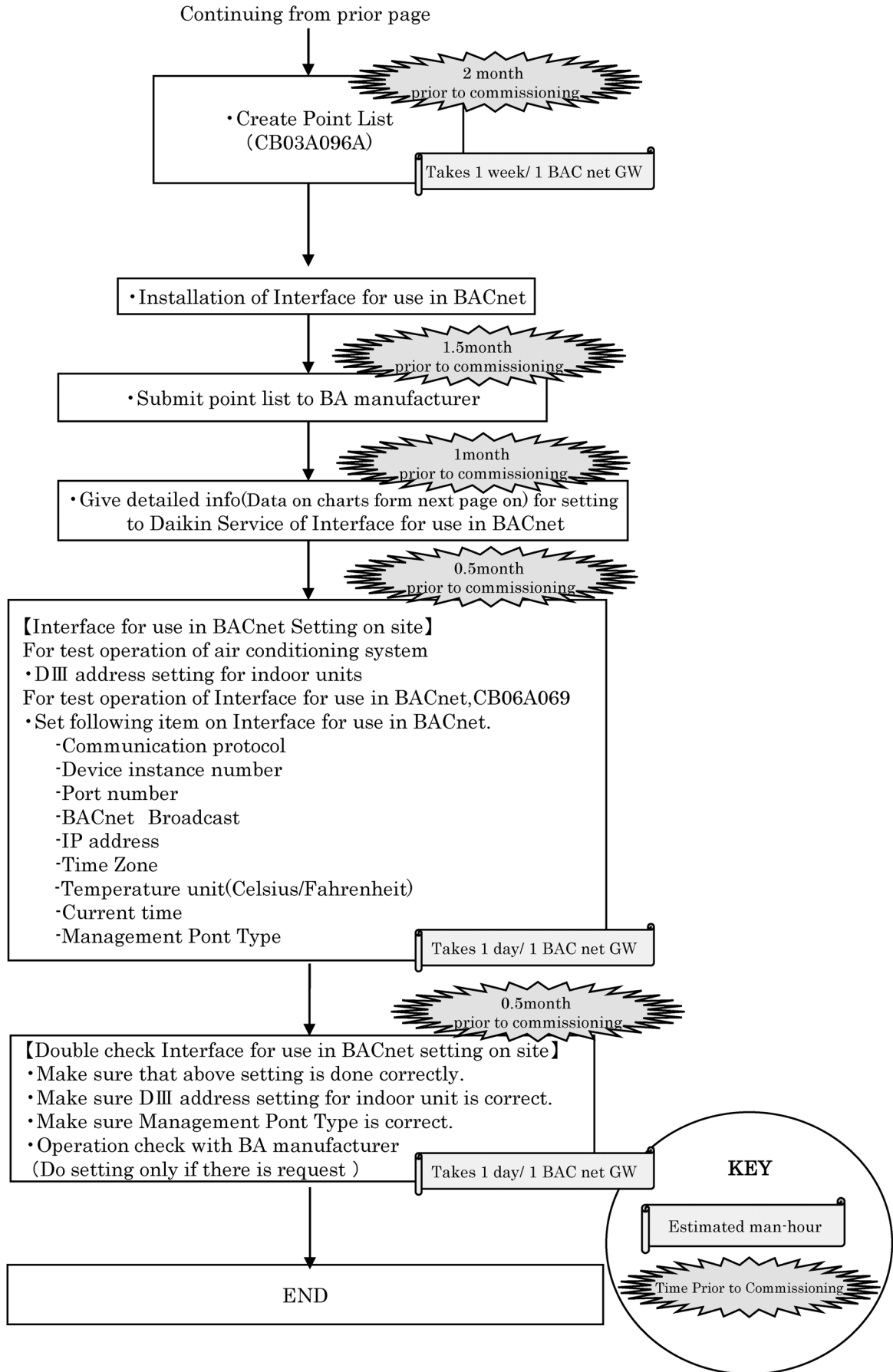

1.2 Initial Settings Required Items for Interface for use in BACnet®

(1) Port No. Setting for BACnet Communication

*: Default setting: 47808 Setting range: 1 to 65535

Port No. Setting for BACnet	
-----------------------------	--

(2) Instance No. set in Interface for use in BACnet

*: Default setting: 0, Setting range: 0 to 4194302

Interface for use in BACnet device instance No.	
---	--

(3) On-site installation drawing related material

- On-site wiring system diagram (materials with the following data)
 - Interface for use in BACnet quantity and installation position
 - Optional DIII Board quantity and installation position
 - Optional Di Board quantity and installation position
 - Materials that show the relationship between the number of AC units and their corresponding DIII-NET addresses and installation positions (drawing, etc.)

Reference example of name and address of AC, and monitoring control items

(*Monitoring control item is changeable per AC.)

Project Point Name		DIII-NET Port Number	AC DIII-NET Address
W1-4 left channels	ON/OFF (setting)	1	1-00
W1-4 left channels	ON/OFF (status)	1	1-00
W1-4 left channels	Alarm Sign	1	1-00
W1-4 left channels	Error Code	1	1-00
W1-4 left channels	Operation Mode (setting)	1	1-00
W1-4 left channels	Operation Mode (status)	1	1-00
W1-4 left channels	Airflow Rate (setting)	1	1-00
W1-4 left channels	Airflow Rate (status)	1	1-00
W1-4 left channels	Measured Room Temperature	1	1-00
W1-4 left channels	Set Room Temperature	1	1-00
W1-4 weak electricity room WC-2A	ON/OFF (setting)	1	1-01
W1-4 weak electricity room WC-2A	ON/OFF (status)	1	1-01
W1-4 weak electricity room WC-2A	Alarm Sign	1	1-01
W1-4 weak electricity room WC-2A	Error Code	1	1-01
W1-4 weak electricity room WC-2A	Operation Mode (setting)	1	1-01
W1-4 weak electricity room WC-2A	Operation Mode (status)	1	1-01
W1-4 weak electricity room WC-2A	Airflow Rate (setting)	1	1-01
W1-4 weak electricity room WC-2A	Airflow Rate (status)	1	1-01
W1-4 weak electricity room WC-2A	Measured Room Temperature	1	1-01
W1-4 weak electricity room WC-2A	Set Room Temperature	1	1-01
W1-4 right channels	ON/OFF (setting)	1	1-02
W1-4 right channels	ON/OFF (status)	1	1-02
W1-4 right channels	Alarm Sign	1	1-02
W1-4 right channels	Error Code	1	1-02
W1-4 right channels	Operation Mode (setting)	1	1-02
W1-4 right channels	Operation Mode (status)	1	1-02

CB07A006C

(4) Monitoring and Controlling Items Executed by BA

Number (For BACnet)	Monitoring/Controlling Item	Object Type (For BACnet)	Activation of central monitoring board per AC (Yes/No) *In case that controlling/monitoring items are different per air conditioner, these should be listed in the previous sheet.
1	ON/OFF(setting)	BO	
2	ON/OFF(status)	BI	
3	Alarm Sign	BI	
4	Error Code	MI	
5	Operation Mode(setting)	MO	
6	Operation Mode(status)	MI	
7	Airflow Rate(setting)	MO	
8	Airflow Rate(status)	MI	
9	Measured Room Temperature	AI	
10	Set Room Temperature	AV	
11	Filter Limit Sign	BI	
12	Filter Limit Sign Reset	BV	
13	Remote Control Operation(ON/OFF)	BV	
14	Remote Control Operation(Operation Mode)	BV	
16	Remote Control Operation(Set Temperature)	BV	
(*1)17	Centralized Control(Sub Group Address Control Operaton rejection)	BV	
(*2)18	Accumulated gas Consumption	Accumulator	
19	Accumulated Power Consumption	Accumulator	
20	Communication Status	BI	
(*1)21	System Forced OFF	BV	
22	Air Direction (setting)	AV	
23	Air Direction (status)	AI	
24	Forced Thermostat OFF (setting)	BO	
25	Forced Thermostat OFF (status)	BI	
26	Energy Efficiency Command (setting)	BO	
27	Energy Efficiency Command (status)	BI	
28	Thermostat Status	BI	
29	Compressor Status	BI	
30	Indoor Fan Status	BI	
31	Heater Operation Status	BI	
32	Ventilation Mode (setting)	MO	
33	Ventilation Mode (status)	MI	
(*3)34	Ventilation Amount (setting)	MO	
(*3)35	Ventilation Amount (status)	MI	

*1: Commands for Centralized Control (17) and System Forced OFF (21) should be given to each DIII-NET communication port.

*2: It is for Japanese market only.

*3: The fresh up (Auto) setting may not be available for monitor/control operation depending on the specifications of the central monitoring panel.

CB07A006C

• BACnet Broadcast Setting

BACnet Broadcast	Select <u>Local</u> or <u>Global</u> . (put a ring around either of them.)
------------------	---

[Remarks]

- Global broadcast or Local broadcast is selectable as BACnet broadcast.
(*This differs from broadcast of UDP/IP.) If selecting Global broadcast, a broadcast message is transmitted to the other BACnet network passing through BACnet router.
If selecting Local broadcast, a broadcast message does not pass BACnet router, so it only reaches to the existed node in the same BACnet network.
(For further details of Global broadcast and Local broadcast, refer to chapter 6.3.2 of ANSI/ASHRAE Standard 135-2004.)
- If a BACnet network with low-speed data communication(ex: BACnet on RS232C) is connected via BACnet router to a station existed BACnet/IP network, the communication line (of the network with low-speed data communication) becomes occupied because unregistered COV is sent to the network from the station at every status change of AC. In this case, Local broadcast must be selected.
- For Who-Is/I-AM service, select Global broadcast even if the above mentioned case (BACnet/IP network) is existed.

(5) IPv4 Address (IP Address)

Use the private address as IP address.

Address and Subnet Mask can be set at arbitrary value on the PC for setting.

Default: Address=192. 168. 0. 1. Subnet Mask=255. 255. 255. 0

(Also record the IP address temporarily used for service test operation. (this IP address is not used except test operation.))

1. IP address which is set to Interface for use in BACnet)

IP Address		Ex: 192.168.0.1
Subnet Mask		Ex: 255.255.255.0
Default Gateway Address		Ex: 192.168.0.100

2. IP address temporarily used for service test operation (not use except test operation)

IP Address		Ex: 192.168.0.2
Subnet Mask		Ex: 255.255.255.0
Default Gateway Address		Ex: 192.168.0.100

Restrictions for Ipv4 Address (The following addresses cannot be set.)

Cannot set IP address to the following invalid addresses:

- Addresses other than Class A to C (1.0.0.0 to 223.255.255.255)
- Loopback addresses (127.0.0.0 to 127.255.255.255)
- All "0" or all "1" is set at host part of IP address ("0" part in binary of Subnet Mask)
- All "0" or all "1" is set at network part of IP address ("1" part in binary of Subnet Mask)

[Ex]

- 244.1.1.1 -> Not Acceptable(Other than Class A to C)
- 127.0.0.1 -> Not Acceptable (Loopback address)
- IP:198.168.1.0/Subnet:255.255.255.0 -> Not Acceptable (All "0" is set at the host part.)
- IP:192.168.0.1/Subnet:192.0.0.0 -> Not Acceptable (All "1" is set at the network part.)

Cannot set Default Gateway address to the following invalid addresses:

- Addresses other than Class A to C (1.0.0.0 to 223.255.255.255)
- Loopback addresses (127.0.0.0 to 127.255.255.255)

Cannot set Subnet Mask to the following invalid addresses (other than 128.0.0.0 to 255.255.255.255, or other than partly serial value in binary, blank available):

[Ex]

- 255.255.255.244 -> Not Acceptable (other than partly serial value in binary digits)

(6) Celsius/Fahrenheit setting

Set the display unit for the temperature sent/received to/from the central monitoring panel in BACnet communications to either "Celsius" or "Fahrenheit."
"Celsius" is set as factory default.

Temperature unit in BACnet communication	Select <u>Celsius</u> or <u>Fahrenheit</u> . (put a ring around either of them.)
---	---

CB07A006C



Warning



- Ask a qualified installer or contractor to install this product. Do not try to install the product yourself. Improper installation can result in water or refrigerant leakage, electrical shock, fire or explosion.
- Use only those parts and accessories supplied or specified by Daikin. Ask a qualified installer or contractor to install those parts and accessories. Use of unauthorised parts and accessories or improper installation of parts and accessories can result in water or refrigerant leakage, electrical shock, fire or explosion.
- Read the User's Manual carefully before using this product. The User's Manual provides important safety instructions and warnings. Be sure to follow these instructions and warnings.

If you have any enquiries, please contact your local importer, distributor and/or retailer.

Cautions on product corrosion

1. Air conditioners should not be installed in areas where corrosive gases, such as acid gas or alkaline gas, are produced.
2. If the outdoor unit is to be installed close to the sea shore, direct exposure to the sea breeze should be avoided. If you need to install the outdoor unit close to the sea shore, contact your local distributor.